

## Instructions for Use

# Advantix odour trap



for Advantix shower channel (reconstruction model), for installation height from 70 mm

**Model**  
4982.93

**Year built (from)**  
04/2016

**viega**

# Table of contents

<b>1</b>	<b>About these instructions for use</b>	<b>3</b>
	1.1 Target groups	3
	1.2 Labelling of notes	3
	1.3 About this translated version	4
<b>2</b>	<b>Product information</b>	<b>5</b>
	2.1 Standards and regulations	5
	2.2 Intended use	5
	2.2.1 Areas of use	5
	2.2.2 Media	5
	2.2.3 Drainage capacity	6
	2.3 Product description	6
	2.3.1 Overview	6
	2.3.2 Technical data	7
	2.4 Information for use	7
<b>3</b>	<b>Handling</b>	<b>8</b>
	3.1 Assembly information	8
	3.1.1 Important note	8
	3.1.2 Installation dimensions	8
	3.2 Assembly	9
	3.2.1 Mounting the odour trap	9
	3.3 Disposal	14

# 1 About these instructions for use

Trade mark rights exist for this document, further information can be found at [viega.com/legal](http://viega.com/legal).

## 1.1 Target groups

The information in this instruction manual is directed at the following groups of people:

- Heating and sanitary professionals and trained personnel

It is not permitted for individuals without the abovementioned training or qualification to mount, install and, if required, maintain this product. This restriction does not extend to possible operating instructions.

The installation of Viega products must take place in accordance with the general rules of engineering and the Viega instructions for use.

## 1.2 Labelling of notes

Warning and advisory texts are set aside from the remainder of the text and are labelled with the relevant pictographs.



### **DANGER!**

This symbol warns against possible life-threatening injury.



### **WARNING!**

This symbol warns against possible serious injury.



### **CAUTION!**

This symbol warns against possible injury.



### **NOTICE!**

This symbol warns against possible damage to property.



Notes give you additional helpful tips.

### 1.3 About this translated version

This instruction for use contains important information about the choice of product or system, assembly and commissioning as well as intended use and, if required, maintenance measures. The information about the products, their properties and application technology are based on the current standards in Europe (e. g. EN) and/or in Germany (e. g. DIN/DVGW).

Some passages in the text may refer to technical codes in Europe/Germany. These should serve as recommendations in the absence of corresponding national regulations. The relevant national laws, standards, regulations, directives and other technical provisions take priority over the German/European directives specified in this manual: The information herein is not binding for other countries and regions; as said above, they should be understood as a recommendation.

## 2 Product information

### 2.1 Standards and regulations

The following standards and regulations apply to Germany / Europe. National regulations can be found on the relevant web site of your country at [viega.com/standards](http://viega.com/standards).

#### Regulations from section: Media

Scope / Notice	Regulations applicable in Germany
Typical domestic wastewater	DIN 1986-3

### 2.2 Intended use

#### 2.2.1 Areas of use

The Advantix odour trap is suitable for use in ViegaAdvantix shower channels base unit model 4982.10 and model 4982.20.

The drain is designed for small to medium volumes of water, which occur in e. g. residential building.

Technical information, see ↗ *Chapter 2.3.2 'Technical data' on page 7.*

The drain is suitable for horizontal connection to the drainpipe.

#### 2.2.2 Media

The drain is intended for draining of household-type wastewater in constant operation, see ↗ *'Regulations from section: Media' on page 5.*

- The short-term temperature of the wastewater may reach up to 95° C. The temperature must be considerably lower in constant operation.
- The pH value must be higher than 4 but lower than 10.

It is not permitted to introduce wastewater which would damage the product material.

### 2.2.3 Drainage capacity

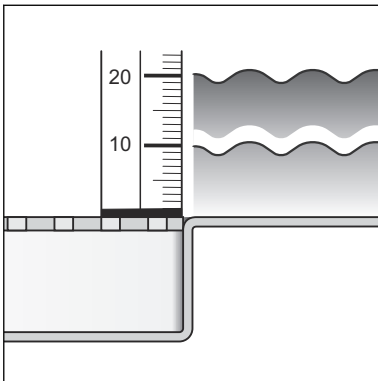

The drainage capacity at an accumulation height of 10 mm above the grate is 0.4 l/s

The drainage capacity at an accumulation height of 20 mm above the grate is 0.45 l/s

## 2.3 Product description

### 2.3.1 Overview

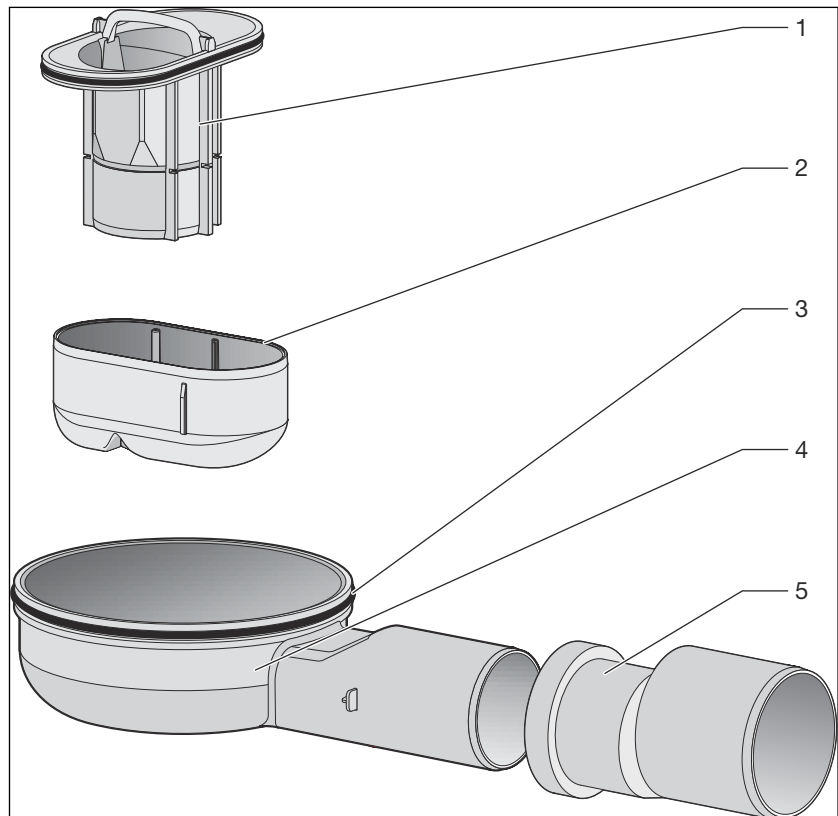

- 1 - Odour trap immersion pipe
- 2 - Odour trap insert
- 3 - O-ring
- 4 - Casing
- 5 - Adapter DN50

### 2.3.2 Technical data

Nominal width [DN] (drain socket)	DN40 / DN50
Drainage capacity	↪ Chapter 2.2.3 'Drainage capacity' on page 6
Dimensions and installation height	↪ Chapter 3.1.2 'Installation dimensions' on page 8
Water seal level	25 mm
Load class	K = 300 kg

## 2.4 Information for use

## 3 Handling

### 3.1 Assembly information

#### 3.1.1 Important note



Observe the instructions for use of the base unit when mounting.

Before assembly:

- Check if the drainage capacity of the drain is sufficient for the arising water volume ↪ *Chapter 2.2.3 'Drainage capacity' on page 6.*
- Check if the installation height of the drain corresponds with the planned floor construction.
- Ensure that the required connection line is installed with the necessary incline to the planned installation location.

During assembly:

- Observe installation dimensions.

#### 3.1.2 Installation dimensions

##### Dimensional drawing

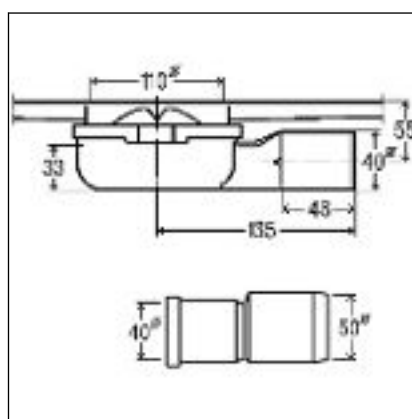

Fig. 1: Dimensional drawing for model 4982.93



## Installation height

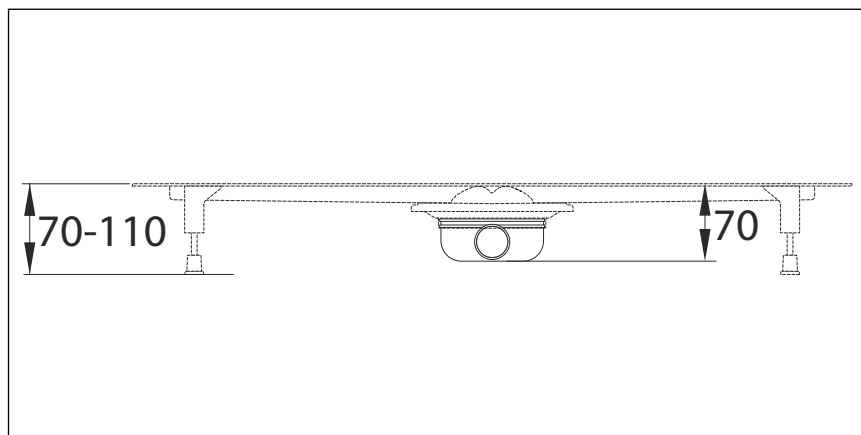
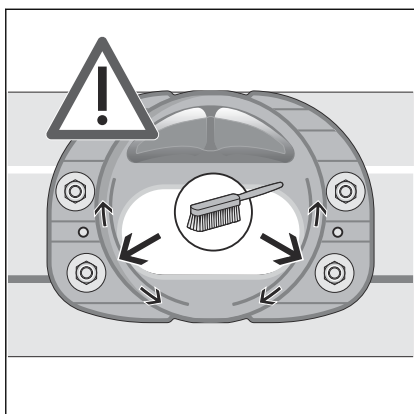

Fig. 2: Installation height for model 4982.93

## 3.2 Assembly

### 3.2.1 Mounting the odour trap



- Check the connection element for soiling, clean if necessary.

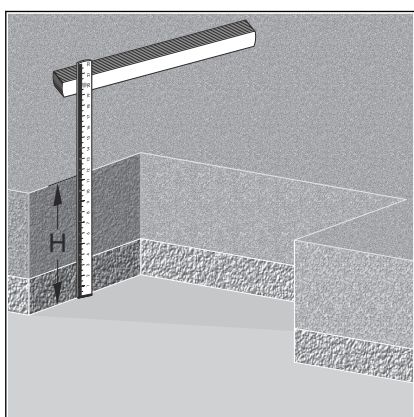

- Determine the screed height.

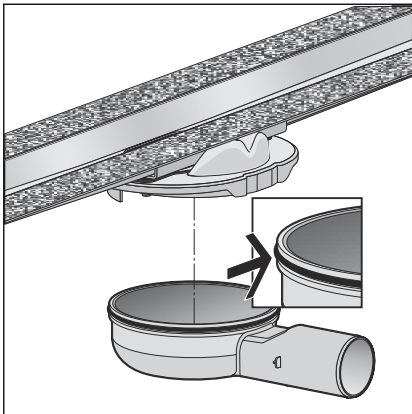

- Mount the sealing element.  
Check the sealing element for firm seat.

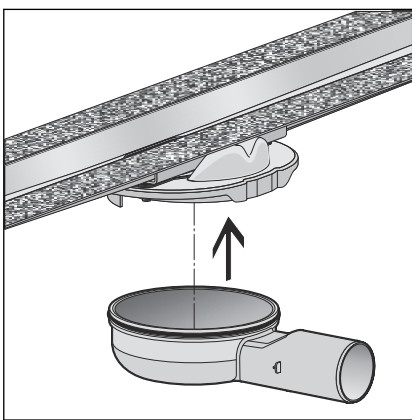

- Press the drain into the connection element until it snaps home.

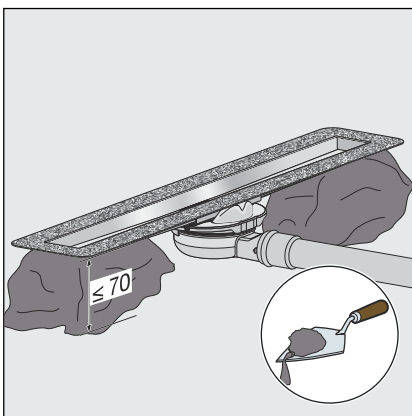

- With mounting heights of max. 70 mm, align the base unit in the mortar bed.

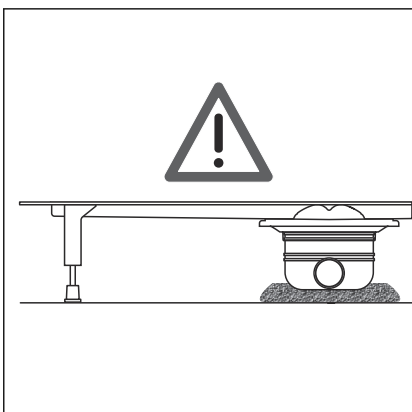

- Provide mortar bedding to secure the drain against slipping.

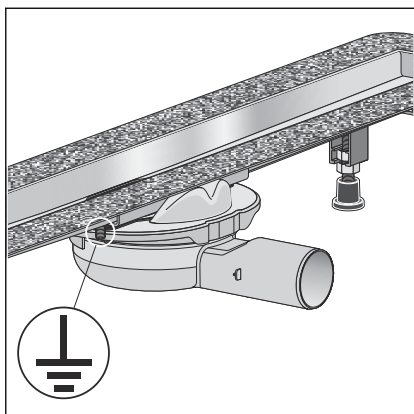

- Check whether grounding is required.

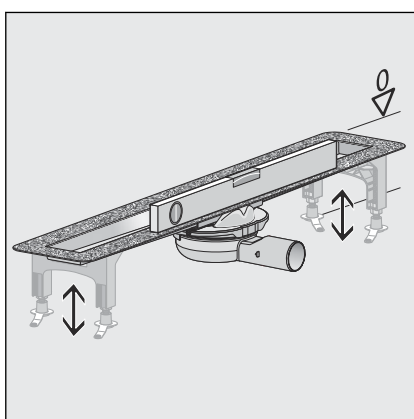

- Set the base unit to the upper edge of the screed.
- Align it horizontally in all directions.

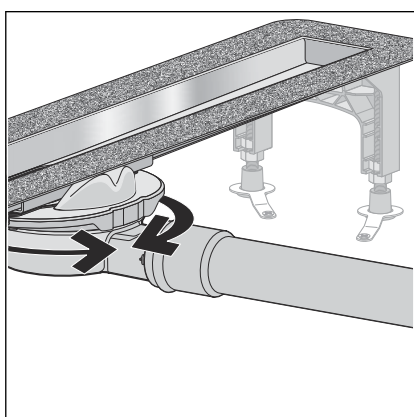

**INFO! The drain is 180° rotatable.**

- Connect the drain DN40 or the adapter element DN50 to the drainage system.

The wastewater pipe can also be laid under the shower channel base unit.

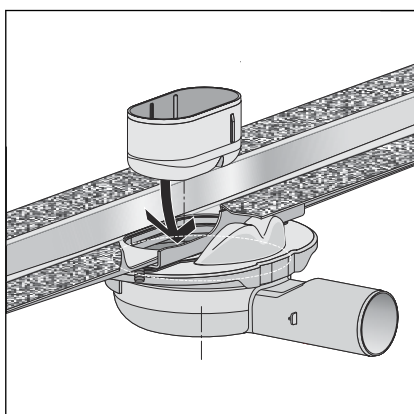

- Put in the odour trap insert.

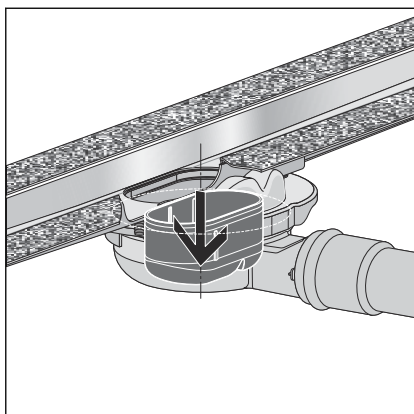

► The odour trap in installed condition.

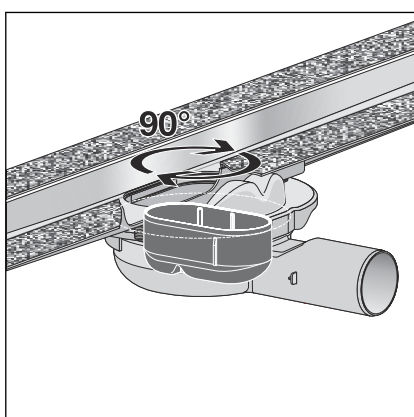

► Turn the odour trap 90° to the right.

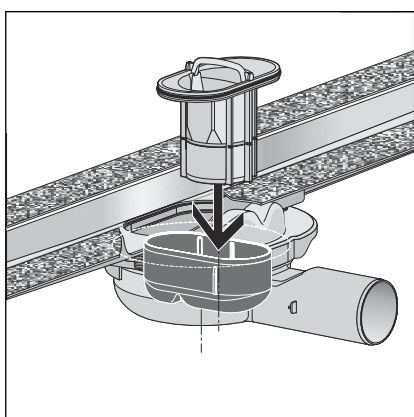

► Mount and grease the sealing element.

► Insert the odour trap immersion pipe.

□ The odour trap insert has been fastened.

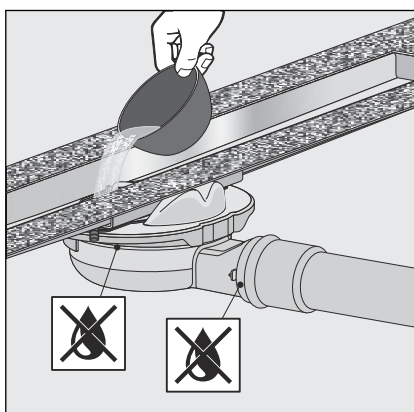

► Check the base unit including the drain and the connection line for leak tightness.

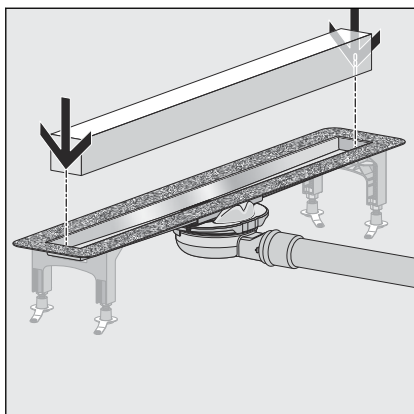

➤ Insert the hard foam block.

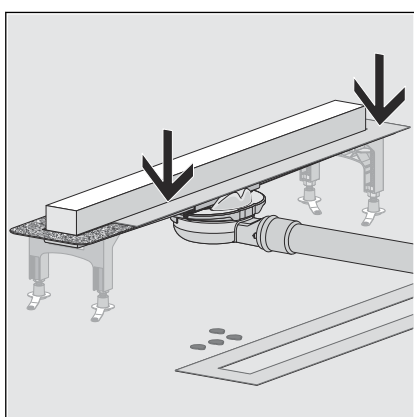

➤ Mount the first part of the site protection.

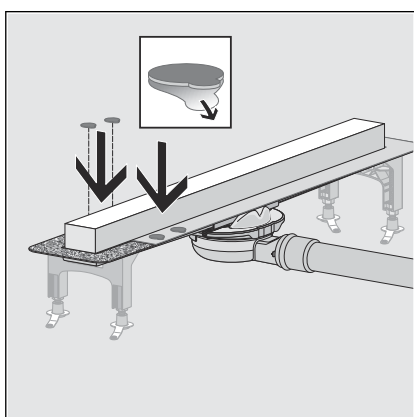

➤ Remove the lower protective foil and stick the adhesive points on.

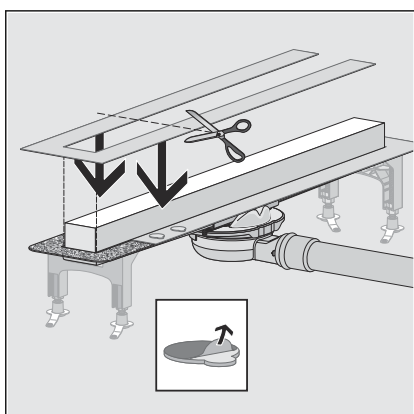

➤ Shorten the second part of the site protection if applicable, and mount it.

➤ Remove the top protective foil of the adhesive point.

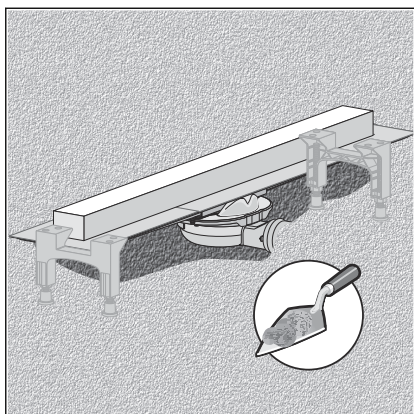

- Line the shower channel incl. the drain up to the upper edge of the flange with screed.

### 3.3 Disposal

Separate the product and packaging materials (e. g. paper, metal, plastic or non-ferrous metals) and dispose of in accordance with valid national legal requirements.



**Viega GmbH & Co. KG**  
service-technik@viega.de  
viega.com

INT • 2022-08 • VPN170009

