

Instructions for Use Smartloop

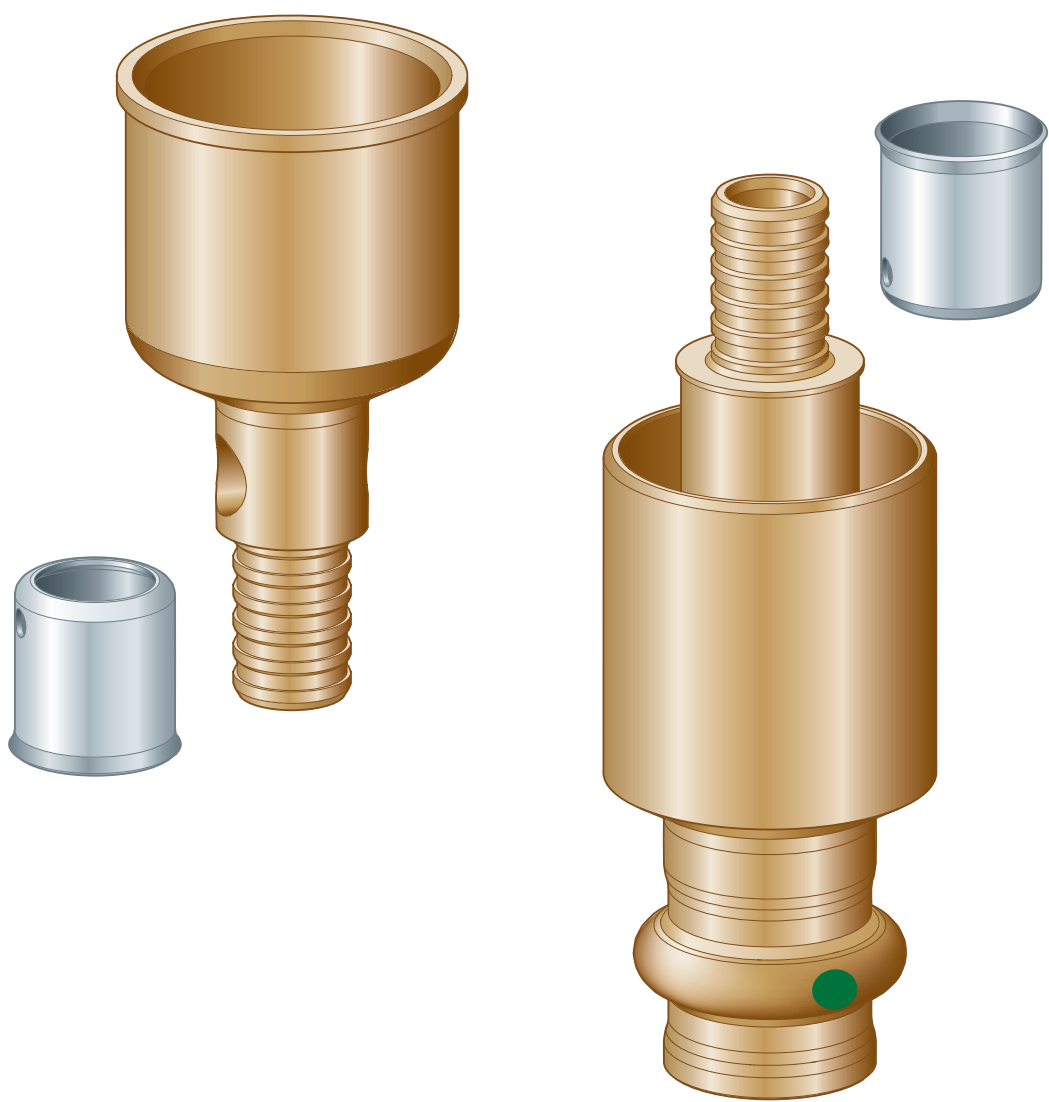

Table of contents

1	About these instructions for use	3
	1.1 Target groups	3
	1.2 Labelling of notes	3
	1.3 About this translated version	4
2	Product information	5
	2.1 Standards and regulations	5
	2.2 Intended use	8
	2.2.1 Areas of application	8
	2.2.2 Media	9
	2.3 Product description	9
	2.3.1 Overview	9
	2.3.2 Compatible components	12
	2.3.3 Technical data	13
3	Handling	14
	3.1 Assembly information	14
	3.1.1 Mounting instructions	14
	3.1.2 Required tools	14
	3.2 Assembly	15
	3.2.1 Installing Smartloop	15
	3.2.2 Leakage test	19
	3.3 Maintenance	19
	3.4 Repairing the riser pipe	19
	3.5 Disposal	20

1 About these instructions for use

Trade mark rights exist for this document; for further information, go to viega.com/legal.

1.1 Target groups

The information in this manual is directed at heating and sanitary professionals and trained personnel.

Individuals without the abovementioned training or qualification are not permitted to mount, install and, if required, maintain this product. This restriction does not extend to possible operating instructions.

The installation of Viega products must take place in accordance with the general rules of engineering and the Viega instructions for use.

1.2 Labelling of notes

Warning and advisory texts are set aside from the remainder of the text and are labelled with the relevant pictographs.



DANGER!

This symbol warns of possible life-threatening injury.



WARNING!

This symbol warns of possible serious injury.



CAUTION!

This symbol warns of possible injury.



NOTICE!

This symbol warns of possible damage to property.



This symbol gives additional information and hints.

1.3 About this translated version

This instruction for use contains important information about the choice of product or system, assembly and commissioning as well as intended use and, if required, maintenance measures. The information about the products, their properties and application technology are based on the current standards in Europe (e.g. EN) and/or in Germany (e.g. DIN/DVGW).

Some passages in the text may refer to technical codes in Europe/Germany. These should serve as recommendations in the absence of corresponding national regulations. The relevant national laws, standards, regulations, directives and other technical provisions take priority over the German/European directives specified in this manual: The information herein is not binding for other countries and regions; as said above, they should be understood as a recommendation.

2 Product information

2.1 Standards and regulations

The following standards and regulations apply to Germany / Europe and are provided as a support feature.

Regulations from section: Intended use

Scope / Notice	Regulations applicable in Germany
Creating potable water installations	DIN 1988-200
Creating potable water installations	EN 806-2
Regulation on material selection	DIN EN 12502-1
Regulation on material selection	Metall-Bewertungsgrundlage (UBA)

Regulations from section: Application areas

Scope / Notice	Regulations applicable in Germany
Planning, execution, operation and maintenance of potable water installations	DIN EN 806, part 1-5
Planning, execution, operation and maintenance of potable water installations	DIN EN 1717
Planning, execution, operation and maintenance of potable water installations	DIN 1988
Planning, execution, operation and maintenance of potable water installations	VDI/DVGW 6023
Planning, execution, operation and maintenance of potable water installations	Trinkwasserverordnung (TrinkwV)
Planning, execution, operation and maintenance of potable water installations	DVGW-Arbeitsblatt W 553

Regulations from section: Media

Scope / Notice	Regulations applicable in Germany
Suitability for potable water	Trinkwasserverordnung (TrinkwV)
Suitability for potable water	DIN 1988-200
Suitability for potable water	EN 806-2

Regulations from section: Product description

Scope / Notice	Regulations applicable in Germany
Suitability for potable water	DIN 50930-6
Suitability for potable water	Trinkwasserverordnung (TrinkwV)
Assessment guidelines of the German Federal Environment Agency	Konformitätsbestätigung der trinkwasserhygienischen Eignung von Produkten nach System 1+

Regulations from section: Compatible components

Scope / Notice	Regulations applicable in Germany
Certification and approval of press connectors	DVGW-Arbeitsblatt W 534
Certification and approval of press connectors for use with copper pipes	DVGW-Arbeitsblatt GW 392
Certification and approval of press connectors for use with copper pipes	DIN EN 1057
Certification and approval of press connectors for use with stainless steel pipes (material 1.4401 / 1.4521)	DVGW-Arbeitsblatt GW 541
Certification and approval of press connectors for use with stainless steel pipes (material 1.4401 / 1.4521)	DIN EN 10312
Certification and approval of press connectors for use with stainless steel pipes (material 1.4401 / 1.4521)	DIN EN 10088
Testing and approval of plastic pipes	DVGW Worksheet W544
Testing and approval of press connectors with multi-layer pipes	DVGW-CERT PEG-W001
Testing and approval of press connectors with multi-layer pipes	DVGW-CERT ZP 8803

Regulations from section: Notes on mounting

Scope / Notice	Regulations applicable in Germany
Cleaning and disinfection of potable water installations	DVGW Arbeitsblatt 557

Regulations from section: Leakage test

Scope / Notice	Regulations applicable in Germany
Regulations for leakage tests	DIN EN 806-4
Regulations for leakage tests	ZVSHK Merkblatt "Dichtheitsprüfungen von Trinkwasserinstallationen mit Druckluft, Inertgas oder Wasser"
Regulations for leakage tests (load and leakage test)	Anforderungen / Bestimmungen der verantwortlichen Klassifizierungsgesellschaft(en)
Regulations for leakage tests (load and leakage test)	Standarddrucktests des ausführenden Betriebs (Werft)

Regulations from section: Maintenance

Scope / Notice	Regulations applicable in Germany
Operation and maintenance of potable water installations	DIN EN 806-5

2.2 Intended use



The press connector system is suitable for the construction of potable water installations in accordance with applicable guidelines, taking into account the selection of materials in accordance with applicable guidelines and in accordance with the assessment basis for materials in contact with potable water of the Federal Environment Agency (UBA), see ↗ 'Regulations from section: Application areas' on page 5. For use in other areas of application and in case of doubt over the correct material selection, contact Viega.

2.2.1 Areas of application

The Smartloop Inliner technology is employed as an internal circulation pipe in potable water installations. The system is particularly suitable for hot water pipes in the sizes d28, d32 and d35.

The general rules of engineering must be observed for planning, execution, operation and maintenance potable water installations, see ↗ 'Regulations from section: Application areas' on page 5.

Viega recommends using the planning software Viega Viptool when dimensioning a potable water installation with Smartloop Inliner technology.

2.2.2 Media

The system is suitable for the following media:

- Potable water
 - see ↗ *'Regulations from section: Media'* on page 6
 - max. chloride concentration 250 mg/l (in acc. with PWO)

2.3 Product description

The Smartloop inliner technology can be used for potable water installations in accordance with applicable directives, see ↗ *'Regulations from section: Product description'* on page 6.

The plastic components correspond to the applicable regulations, see ↗ *'Regulations from section: Product description'* on page 6.

2.3.1 Overview

The Smartloop system consists of the following components:

- Smartloop connection set (model 2276.1)
- Smartloop pipe (model 2007.3)
- Smartloop tension coupling (model 2276.9)
- Smartloop repair coupling (model 2276.8)

The system components are available in the following dimensions:

- End closing piece/connecting piece d = 28, 35, 28 / 35
- Smartloop pipe d12

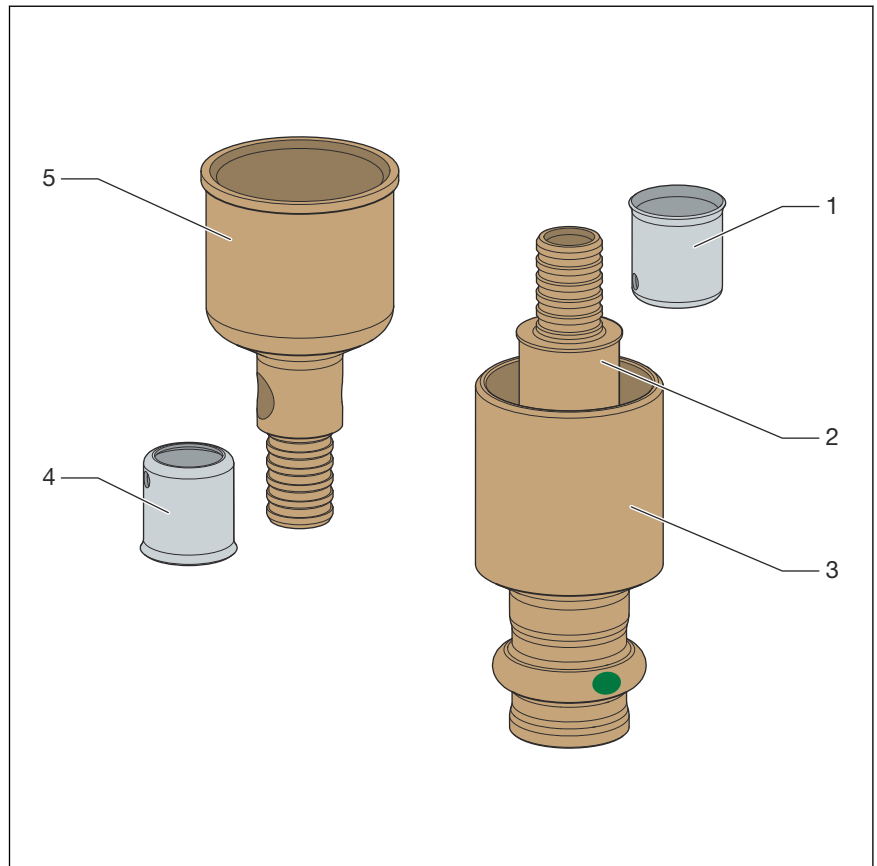

Fig. 1: Connection set, model 2276.1

- 1 - Press sleeve
- 2 - Adapter
- 3 - Connecting piece
- 4 - Press sleeve
- 5 - End closing piece

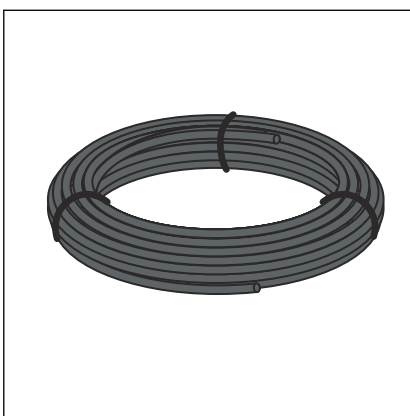
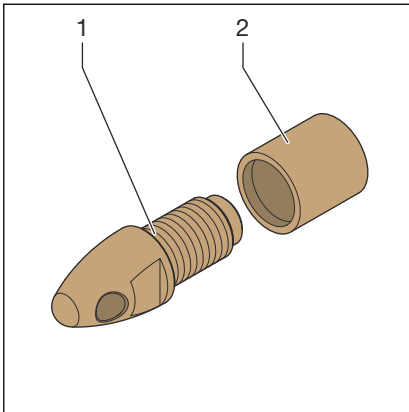
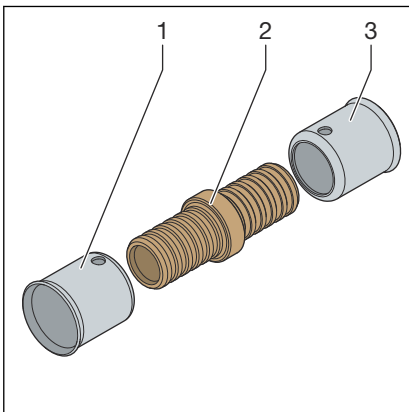

Fig. 2: Pipe, model 2007.3



- 1 - Tension head
- 2 - Support sleeve

Fig. 3: Tension coupling, model 2276.9



- 1 - Press sleeve
- 2 - Repair coupling
- 3 - Press sleeve

Fig. 4: Repair coupling, model 2276.8

Operating mode

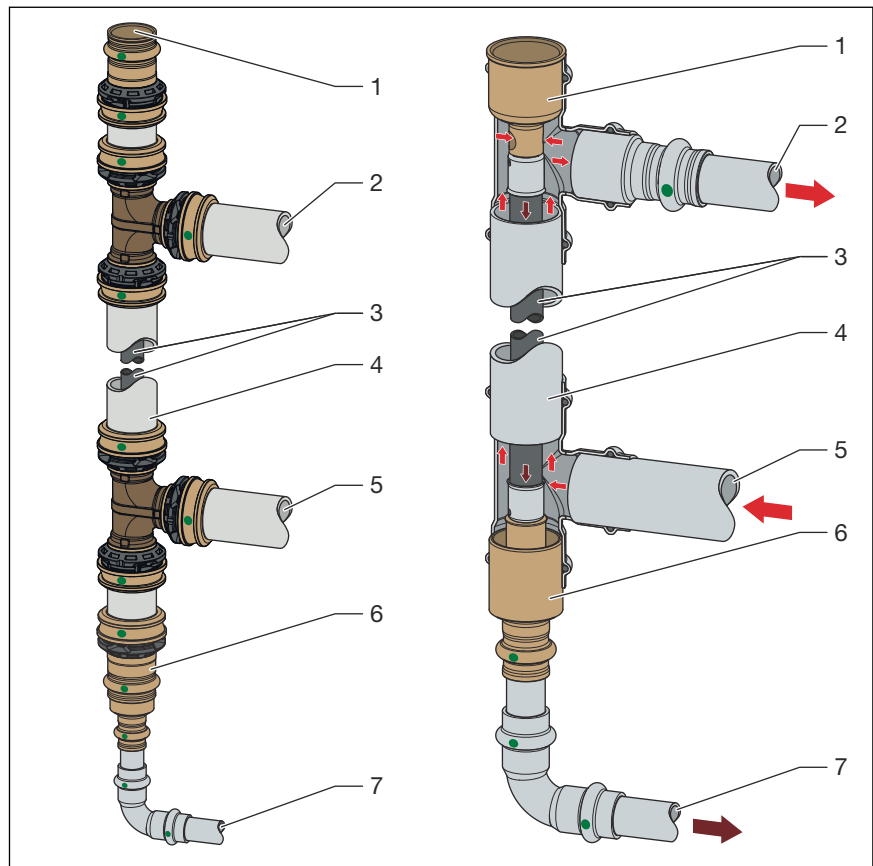

Fig. 5: Functional principle Smartloop inliner technology

- 1 End closing piece
- 2 Hot water storey connection pipe
- 3 Internally positioned circulation pipe
- 4 Hot water pipe
- 5 Hot water supply pipe
- 6 Connecting piece
- 7 Circulation collector line

Circulation in the hot water leg is achieved as follows: The hot water is connected to the hot water manifold (5). The hot water flows in the hot water pipe (4) to the storey connection pipes (2). The opening in the end closing piece (1), which is installed in the last T-piece of the storey connection pipe (2), ensures that the hot water flows through the internal circulation pipe (3) and thus circulates via the circulation collecting pipe. The temperature of the return flow water is higher than with conventional circulation systems, which, in turn, has advantages in terms of energy.

2.3.2 Compatible components

The model is equipped with press connections and compatible with the following systems:

- Profipress
- Sanpress

- Sanpress Inox
- Raxofix
- Viega Smartpress

Pipes

The press connections are tested and approved according to the applicable regulations with the following pipe types, see also ↗ *'Regulations from section: Compatible components'* on page 7:

- Copper pipes
- Stainless steel pipes (material 1.4401 / 1.4521)
- Multi-layer pipes

2.3.3 Technical data

Observe the following operating conditions for the installation of the system:

Operating temperature	70 °C T _{max} : 95 °C t _{max} : 60 min ¹⁾
Operating pressure	1.0 MPa (10 bar)
Comments	see notes ↗ <i>Chapter 2.2.2 'Media'</i> on page 9

¹⁾ According to applicable regulations, see ↗ *'Regulations from section: Intended use'* on page 5



The sealing materials of the press connector system are subject to thermal ageing, which depends on the media temperature and the service life. The higher the media temperature, the faster the thermal ageing of the sealing material progresses. In the case of special operating conditions such as industrial heat recovery systems, it is necessary to compare the specifications of the equipment manufacturer with the specifications of the press connector system.

Before using the press connector system outside the described areas of application or if in doubt about the correct material selection, please contact Viega.

3 Handling

3.1 Assembly information

3.1.1 Mounting instructions

Checking system components



Make sure the area is completely clean when installing the pipe, see [↗](#) 'Regulations from section: Notes on mounting' on page 7.

Do not remove the parts from the packaging until immediately before use.

System components may, in some cases, become damaged through transportation and storage.

- Check all parts.
- Replace damaged components.
- Do not repair damaged components.
- Contaminated components may not be installed.



For information on *installing pipelines, fixing and length expansion*, refer to the instructions for use relating to the system in question.

3.1.2 Required tools

Press connection



Viega recommends the use of Viega system tools when installing the press fittings.

The Viega system press tools have been developed and tailored specifically for the installation of Viega press connector systems.

Smartloop pipe

The following tools are required for mounting the Smartloop pipe:

- Pipe shear, model 5341
- Mounting pliers, model 1077.2
- Hand press tool, model 2782 or press jaw, model 2799.7

3.2 Assembly

3.2.1 Installing Smartloop

Maximum offset of the hot water pipe

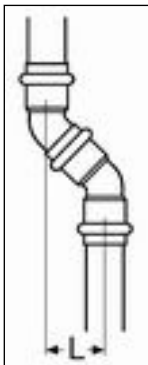
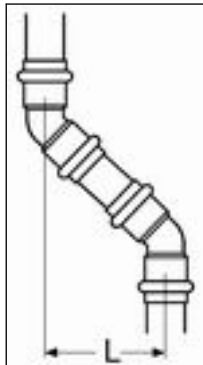
Offset ¹⁾		
Redirection L [mm]	≥40–45	≥45–500
Components required	1 elbow 45° 1 elbow 45° with plug-in end	2 elbows 45°
number	Only carry out one offset per leg.	

¹⁾ An offset may only be carried out on metallic piping systems.

Any installation variations differing from those shown should be agreed with the Viega Service Center.

Procedure



Pressing with a handtool is shown in the following assembly steps. Alternatively, a suitable Viega press machine with the corresponding press jaws can be used
 ↪ Chapter 3.1.2 'Required tools' on page 14.

Requirements:

- The riser pipe is created.
- The riser pipe consists of the approved pipes, see [Chapter 2.3.2 'Compatible components'](#) on page 12.
- The riser pipe dimension is at least d28 and maximum d35.
- Prepare the pipe for installation.

Install the tension coupling (model 2276.9) on the pipe end using a fork spanner (SW 10).

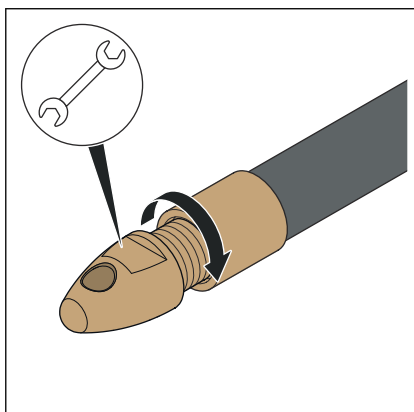

- Push the pipe into the hot water pipe from above.

NOTICE! Do not use grease or lubricant to insert the pipe.

The pipe must protrude from the lower end of the riser pipe by approx. 30 cm.

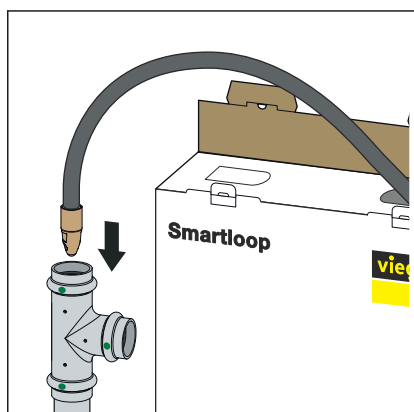

- Cut the pipe to length at a right angle.

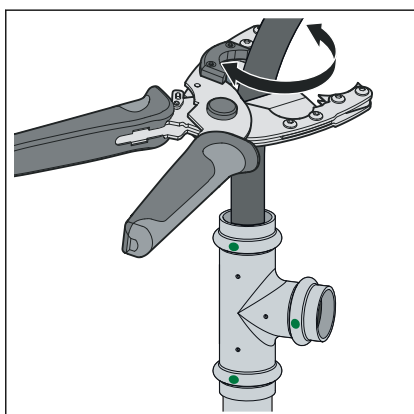

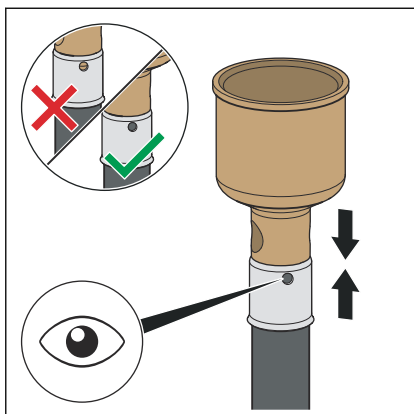

- Push a press sleeve onto the top pipe end.
- Push the end closing piece into the Smartloop pipe.
- Check the insertion depth in the inspection window.

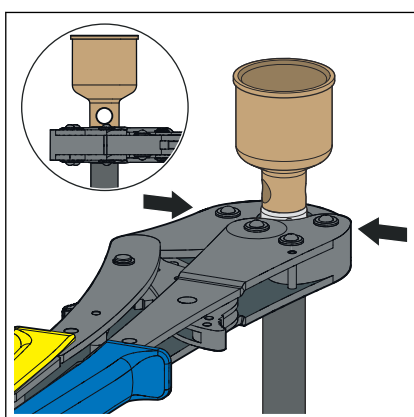

- Apply the press tool at a right-angle.
- When pressing, press the hand press tool until the pliers can be re-opened.

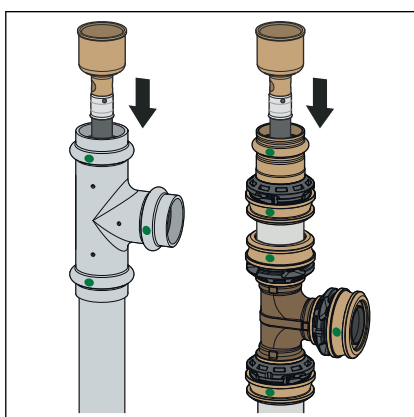

- Insert the end closing piece into the upper T-piece of the hot water pipe.
If necessary, use a reducer.

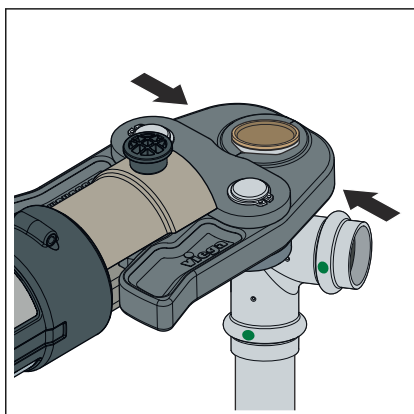

- Press the connection.

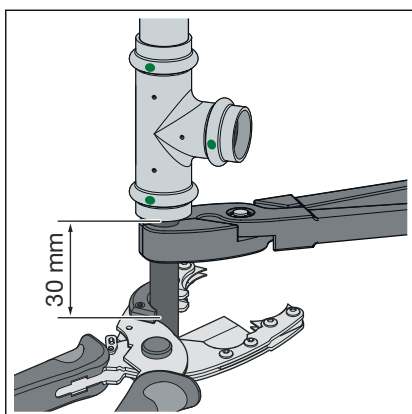

- Tighten the pipe on the lower end using the mounting pliers.
- Continue to hold the pipe tightly and shorten it 30 mm below the T-piece.

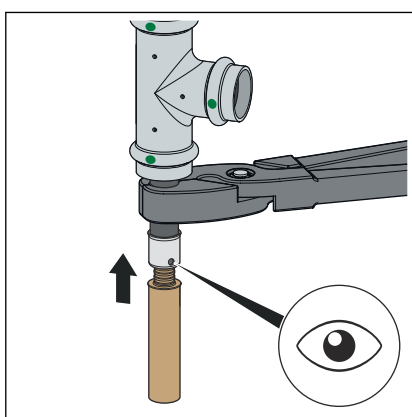

- Push a press sleeve onto the lower pipe end.
- Push the adapter into the pipe.
- Check the insertion depth in the inspection window.

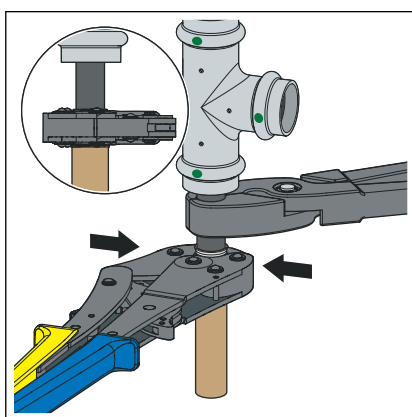

- Apply the press tool at a right-angle.
- When pressing, press the hand press tool until the pliers can be re-opened.

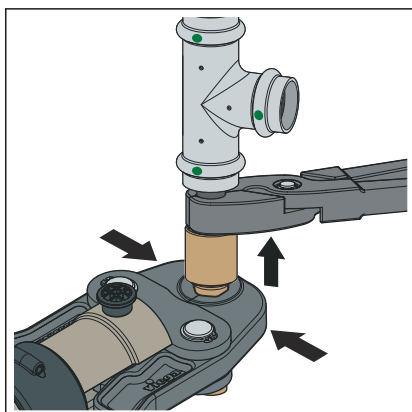

- Push the connecting piece into the adapter as far as it will go and press.
- Remove the mounting pliers.

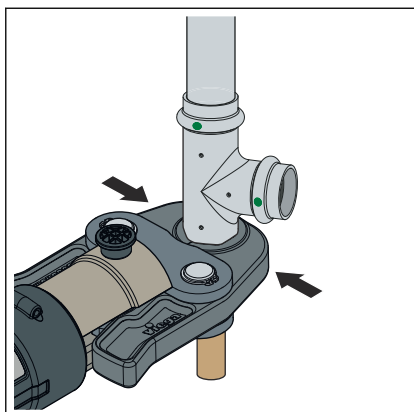

- Insert the connecting piece into the lower T-piece of the hot water pipe as far as it will go and press.

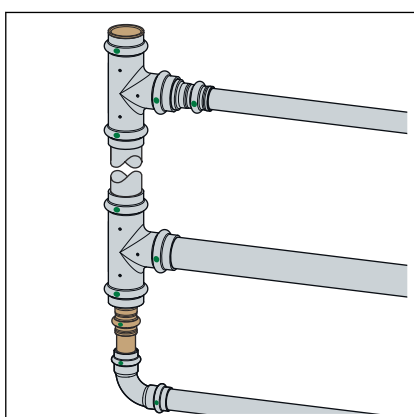

- Connect the hot water pipe and the circulation pipe to the corresponding cellar supply and collector lines.
- Perform a leakage test.
- Attach the “Internal circulation pipe” information sign to the finished hot water pipe in a visible place.

3.2.2 Leakage test

The installer must perform a leakage test before commissioning.

Carry out this test on a system that is finished but not covered yet.

Comply with the general rules of engineering and the applicable directives, see [☞ ‘Regulations from section: Leakage test’ on page 8.](#)

Document the result.

3.3 Maintenance



NOTICE!

Inform your customer or the operator of the potable water installation that the system has to be maintained on a regular basis.

3.4 Repairing the riser pipe



For repairs, please contact the Viega Service Center.

3.5 Disposal

Separate the product and packaging materials (e. g. paper, metal, plastic or non-ferrous metals) and dispose of in accordance with valid national legal requirements.



Viega GmbH & Co. KG
service-technik@viega.de
viega.com

INT • 2023-03 • VPN220371

