

Instructions for Use

Temponox XL

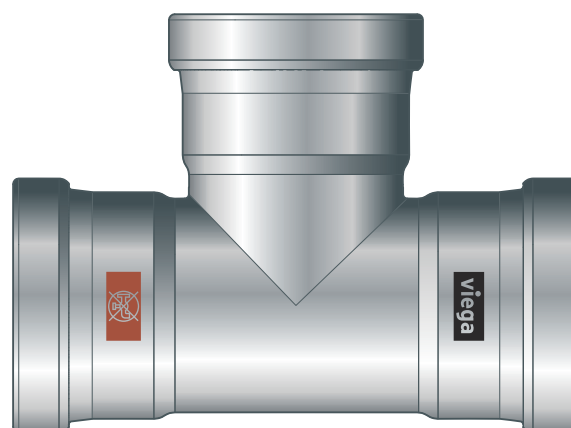

Stainless steel press connector system for stainless steel pipes

System
Temponox XL

Year built (from)
10/2021

viega

Table of contents

1	About these instructions for use	3
	1.1 Target groups	3
	1.2 Labelling of notes	3
	1.3 About this translated version	4
2	Product information	5
	2.1 Standards and regulations	5
	2.2 Intended use	6
	2.2.1 Areas of application	7
	2.2.2 Media	7
	2.3 Product description	8
	2.3.1 Overview	8
	2.3.2 Pipes	8
	2.3.3 Press connectors	11
	2.3.4 Sealing elements	12
	2.3.5 Markings on components	13
	2.4 Information for use	15
	2.4.1 Corrosion	15
3	Handling	16
	3.1 Transport	16
	3.2 Storage	16
	3.3 Assembly information	16
	3.3.1 Mounting instructions	16
	3.3.2 Potential equalisation	17
	3.3.3 Permitted exchange of sealing elements	17
	3.3.4 Space requirements and intervals	18
	3.3.5 Required tools	19
	3.4 Assembly	20
	3.4.1 Replacing the sealing element	20
	3.4.2 Cutting pipes to length	21
	3.4.3 Deburring the pipes	21
	3.4.4 Pressing the connection	22
	3.4.5 Flange connections	24
	3.4.6 Leakage test	31
	3.5 Disposal	31

1 About these instructions for use

Trade mark rights exist for this document; for further information, go to viega.com/legal.

1.1 Target groups

The information in this manual is directed at heating and sanitary professionals and trained personnel.

Individuals without the abovementioned training or qualification are not permitted to mount, install and, if required, maintain this product. This restriction does not extend to possible operating instructions.

The installation of Viega products must take place in accordance with the general rules of engineering and the Viega instructions for use.

1.2 Labelling of notes

Warning and advisory texts are set aside from the remainder of the text and are labelled with the relevant pictographs.



DANGER!

This symbol warns of possible life-threatening injury.



WARNING!

This symbol warns of possible serious injury.



CAUTION!

This symbol warns of possible injury.



NOTICE!

This symbol warns of possible damage to property.



This symbol gives additional information and hints.

1.3 About this translated version

This instruction for use contains important information about the choice of product or system, assembly and commissioning as well as intended use and, if required, maintenance measures. The information about the products, their properties and application technology are based on the current standards in Europe (e.g. EN) and/or in Germany (e.g. DIN/DVGW).

Some passages in the text may refer to technical codes in Europe/Germany. These should serve as recommendations in the absence of corresponding national regulations. The relevant national laws, standards, regulations, directives and other technical provisions take priority over the German/European directives specified in this manual: The information herein is not binding for other countries and regions; as said above, they should be understood as a recommendation.

2 Product information



These instructions for use contain videos

Some assembly and action steps are shown using the example of a piping system other than the one described here, but are equally applicable.

2.1 Standards and regulations

The following standards and regulations apply to Germany / Europe and are provided as a support feature.

Regulations from section: Media

Scope / Notice	Regulations applicable in Germany
Suitability for low-salt / saline potable water	VDI-Richtlinie 2035, Table 1
Suitability for heating water for pump hot water heating systems	VDI-Richtlinie 2035, Sheet 1 and Sheet 2

Regulations from section: Sealing elements

Scope / Notice	Regulations applicable in Germany
Area of application of the EPDM sealing element ■ Heating	DIN EN 12828

Regulations from section: Corrosion

Scope / Notice	Regulations applicable in Germany
Entry of oxygen during re-filling of a system	DIN EN 14868
Oxygen content in low-salt / saline water	VDI-Richtlinie 2035 Table 1
Prevention of damage in water heating installations	VDI 2035 Sheet 1 and 2

Regulations from section: Storage

Scope / Notice	Regulations applicable in Germany
Requirements for material storage	DIN EN 806-4, Chapter 4.2

Regulations from section: Establishing a flange connection

Scope / Notice	Regulations applicable in Germany
Qualification of personnel for the assembly of flange connections	VDI-Richtlinie 2290
Determination of tightening torques	DIN EN 1591-1

Regulations from section: Leakage test

Scope / Notice	Regulations applicable in Germany
Test on a system that is finished but not yet covered	DIN EN 806-4
Leakage test for water installations	ZVSHK-Merkblatt: "Dichtheitsprüfungen von Trinkwasserinstallationen mit Druckluft, Inertgas oder Wasser"
Requirements for filling and top-up water	VDI 2035

2.2 Intended use



Agree the use of the system for areas of application and media other than those described with Viega.

2.2.1 Areas of application



Fig. 1: "Non-potable water"

The system is intended for use in closed heating and cooling circuits. The system is not suitable for use in potable water installations. Pipes and press connectors are therefore marked with a brown symbol "Not potable water".

The press connector system is designed for nominal pressure PN 16.

Use is possible in the following areas among others:

- Closed heating and cooling circuits
- Solar installations with flat collectors
- Solar installations with vacuum tube collectors (only with FKM sealing element)
- Compressed air systems
- Systems for technical gases (on request)

For information on areas of application of the sealing elements, see [Chapter 2.3.4 'Sealing elements' on page 12](#).



For use in other areas of application and in case of doubt over the correct material selection, contact Viega.

2.2.2 Media

The system can be employed in closed water circuits, into which no oxygen can enter during operation.

The following limits are valid for the oxygen content, see ['Regulations from section: Media' on page 5](#):

- Low-salt water ≤ 0.1 mg/l
- Saline water < 0.02 mg/l

The system is suitable for the following media, amongst others:

For the applicable directives, see ↗ ‘Regulations from section: Media’ on page 5.

- Heating water for pump hot water heating systems
- Compressed air (dry) in compliance with the specification of the sealing elements being used
 - EPDM at oil concentration < 25 mg/m³
 - FKM at oil concentration ≥ 25 mg/m³
- Anti-freeze, cooling brines up to a concentration of 50 %

2.3 Product description

2.3.1 Overview

The piping system consists of press connectors in connection with stainless steel pipes and the corresponding press tools.

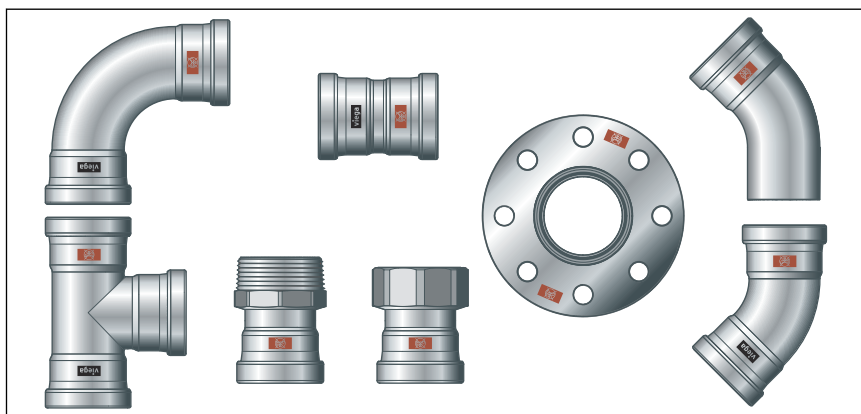

Fig. 2: Product selection

The system components are available in the following dimensions:
d 76.1 / 88.9 / 108.0.

2.3.2 Pipes

The system pipes are available in a length of 6 m.

The following pipes are available from the system described:

Type of pipe	Temponox pipe 1.4520
d	76.1 / 88.9 / 108.0
Area of application	Closed heating and cooling circuits ¹⁾
Material No.	1.4520 (X2CrTi17)

¹⁾ For more detailed information, see Areas of application for metal installation systems.

Type of pipe	Temponox pipe 1.4520
Pipe marking	brown line
Protective cap	brown

¹⁾ For more detailed information, see Areas of application for metal installation systems.

Pipe key data Temponox pipe 1.4520

d x s [mm]	Volume per metre of pipe [l/m]	Pipe weight [kg/m]
76.1 x 1.5	4.20	2.80
88.9 x 1.5	5.80	3.28
108.0 x 1.5	8.66	4.00

Laying and fixing pipes

Only pipe clamps with chloride-free sound insulating inlays should be used to secure the pipes.

Observe the general rules of fixing technology:

- Do not use fixed pipelines as a support for other pipelines and components.
- Do not use pipe hooks.
- Observe distance to press connectors.
- Observe the expansion direction: Plan fixed and gliding points.

Make sure to affix the pipelines in such a way as to de-couple them from the installation body, so that they cannot transfer any structure-borne sound, resulting from thermal expansion or possible pressure surges, onto the installation body or other components.

Observe the following fixing distances:

Distance between the pipe clamps

d [mm]	Fixing distance between the pipe clamps [m]
76.1	4.25
88.9	4.75
108.0	5.00

Length expansion

Pipelines expand with heat. Heat expansion is dependent on the material. Changes in length lead to tension within the installation. These tensions must be compensated for with suitable measures.

The following are effective:

- Fixed and gliding points
- Expansion equalisation joints (expansion bends)

Heat expansion co-efficients of various pipe materials

Material	Heat expansion co-efficient α [mm/mK]	Example: Length extension with pipe length $L = 20$ m and $\Delta\theta = 50$ K [mm]
Stainless steel 1.4520	0.0108	10.8

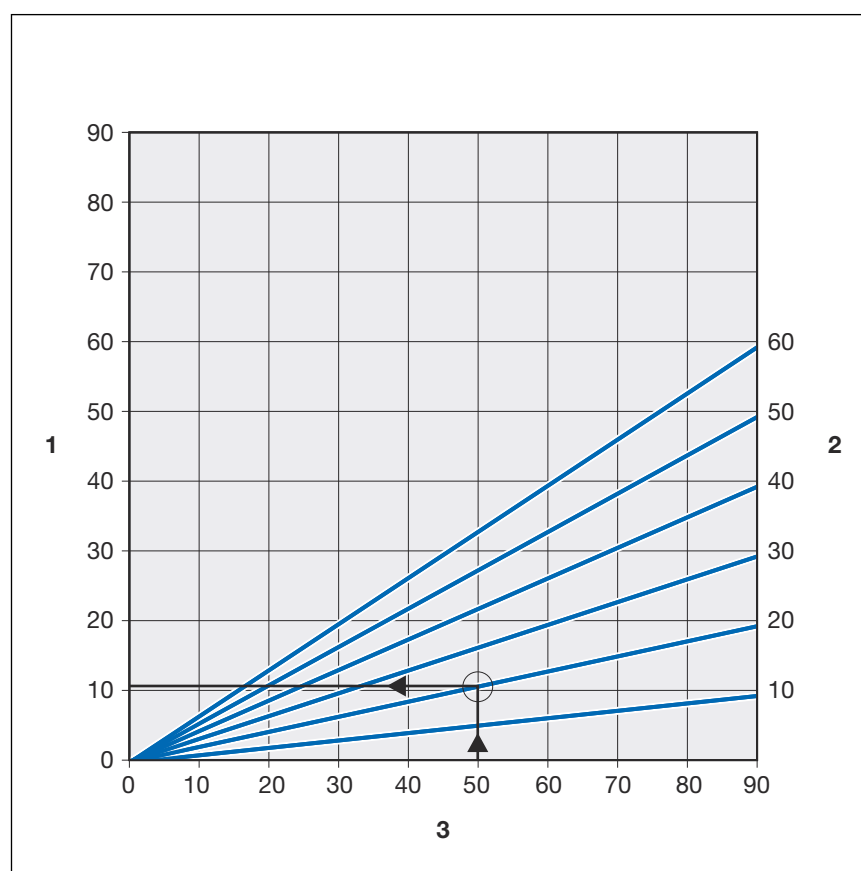

Fig. 3: Length expansion of Temponox pipe 1.4520

- 1 - Length expansion $\vec{\Delta}l$ [mm]
- 2 - Pipe length \vec{l}_0 [m]
- 3 - Temperature difference $\vec{\Delta}\theta$ [K]

The length expansion Δl can be taken from the diagram or can be calculated using the following formula:

$$\Delta l = \alpha \text{ [mm/mK]} \times L \text{ [m]} \times \Delta\theta \text{ [K]}$$

Mixed installation

In addition to the Temponox XL press connectors, the Temponox XL pipe 1.4520 can also be combined with Profipress XL-, Sanpress Inox XL and Sanpress XL press connectors.

In areas of application with possible condensate formation, for instance in closed cooling circuits or in humid environments, Viega recommends the use of Temponox XL, Sanpress XL and Sanpress Inox XL press connectors.

- When using copper Profipress XL press connectors in the aforementioned areas of application, the connection points between the Temponox XL pipe 1.4520 and the copper Profipress XL press connectors must be additionally protected by a corrosion protection agent.
- When using closed-cell insulating tubes, carefully seal all abutting and cut edges with a suitable filler.



For use in other areas of application and in case of doubt over the correct material selection, contact Viega.

2.3.3 Press connectors

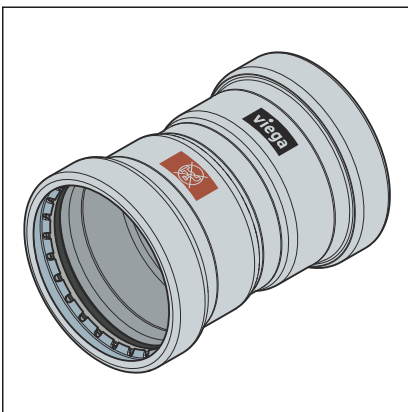

Fig. 4: Press connectors

On Temponox XL press connectors, there is a cutting ring, a separator ring and a sealing element in the bead of the press connector. The cutting ring cuts into the pipe during pressing and ensures a force-fit connection.

During installation, and later during the pressing, the separator ring protects the sealing element from damage from the cutting ring.

SC-Contur

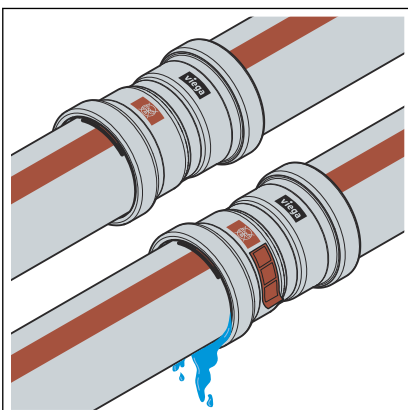

Fig. 5: SC-Contur

Viega press connectors are equipped with the SC-Contur. SC-Contur is a safety mechanism certified by the DVGW and ensures that the press connector leaks in an unpressed state. In this way, inadvertently unpressed connections are noticed during a leakage test.

Viega guarantees that accidentally unpressed connections become visible during a leakage test:

- with the wet leakage test in the pressure range from 0.1–0.65 MPa (1.0–6.5 bar)
- with dry leakage test in the pressure range from 22 hPa–0.3 MPa (22 mbar–3.0 bar)

2.3.4 Sealing elements

The press connectors are factory-fitted with EPDM sealing elements. For areas of application with higher temperatures, such as solar installations with vacuum tube collectors, the press connectors must be equipped with FKM sealing elements.

If the collector type (flat / vacuum tube collector) has not yet been determined at the time of laying the connection pipe to the solar-energy installation, Viega recommends using FKM sealing elements in the press connectors.

The sealing elements can be distinguished as follows:

- EPDM sealing elements are polished black.
- FKM sealing elements are matt black.

Area of use of the EPDM sealing element

Area of application	Closed heating circuits	Solar installations	Cooling circuits	Compressed air	Technical gases
Use	Pump hot water heating system	Solar circuit	Secondary circuit closed	all pipeline sections	all pipeline sections
Operating temperature [T _{max.}]	95 °C	—	≥ -25 °C	60 °C	—
Operating pressure [P _{max.}]	—	0.6 MPa (6 bar)	1.6 MPa (16 bar)	1.6 MPa (16 bar)	—
Comments	pursuant to the applicable regulations ²⁾ T _{max.} : 105 °C with radiator connection T _{max.} : 95 °C	for flat collectors	Inhibitor for water chiller, see material resistance	dry, oil content < 25 mg / m ³ ³⁾	¹⁾ ³⁾

¹⁾ Consultation with Viega required

²⁾ see  'Regulations from section: Sealing elements' on page 5

³⁾ See also document "Areas of application for metal installation systems" on the Viega website

Area of use of the FKM sealing element

Area of application	Solar installations	Compressed air
Use	Solar circuit	all pipeline sections
Operating temperature [T _{max.}]	¹⁾	60 °C

¹⁾ Consultation with Viega required.

²⁾ See also document "Areas of application for metal installation systems" on the Viega website

Area of application	Solar installations	Compressed air
Operating pressure [P _{max}]	0.6 MPa (6 bar)	1.6 MPa (16 bar)
Comments	For flat / vacuum tube collectors 2)	dry 2)

1) Consultation with Viega required.

2) See also document “Areas of application for metal installation systems” on the Viega website



The sealing materials of the press connector system are subject to thermal ageing, which depends on the media temperature and the service life. The higher the media temperature, the faster the thermal ageing of the sealing material progresses. In the case of special operating conditions such as industrial heat recovery systems, it is necessary to compare the specifications of the equipment manufacturer with the specifications of the press connector system.

Before using the press connector system outside the described areas of application or if in doubt about the correct material selection, please contact Viega.

2.3.5 Markings on components

Pipe marking

Temponox pipe 1.4520

Two brown lines offset by 180°

Brown lettering

Brown symbol "Not suitable for potable water!"

The pipe markings contain important information regarding the material configuration and manufacture of the pipes. The brown line on the pipes serves as a warning: "Not suitable for potable water!".

The meaning of the marking is as follows:

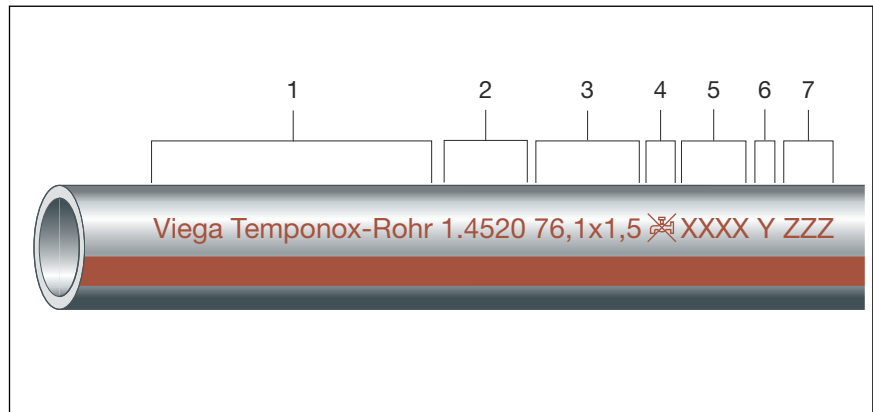
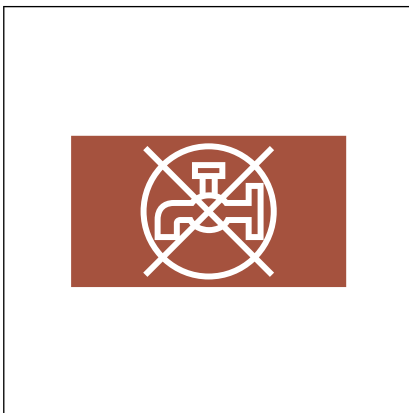

Fig. 6: Temponox pipe 1.4520

- 1 - System manufacturer / system name
- 2 - DIN material number
- 3 - d x s
- 4 - Symbol "Not suitable for potable water!"
- 5 - Date of manufacture
- 6 - Manufacturer identification mark
- 7 - Batch number

Markings on press connectors



The brown rectangle serves as a warning: "Not suitable for potable water!".

The rectangle is to be found in the following places:

- On the press end of the press connector
- On the flange of the flange adapter

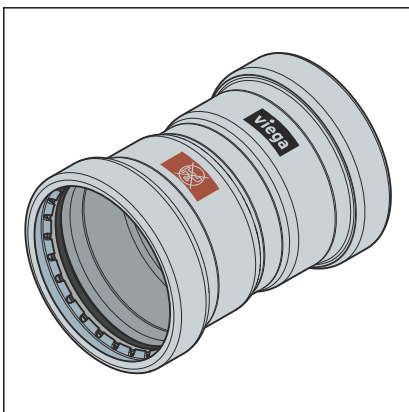

Fig. 7: Marking "Not suitable for potable water"

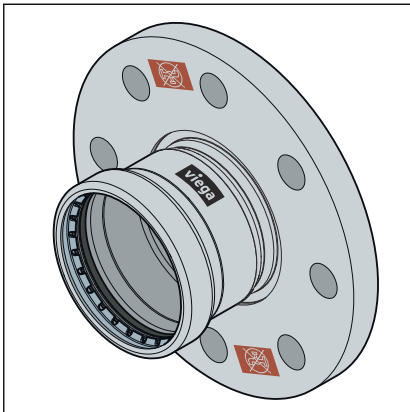

Fig. 8: Marking "Not suitable for potable water"

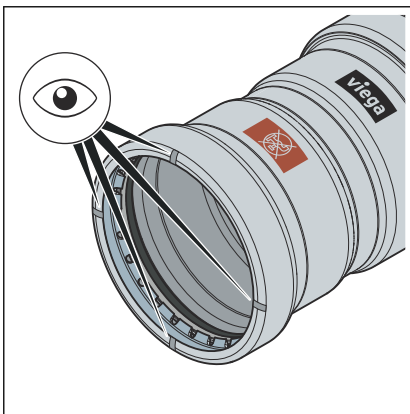

Fig. 9: Notches Temponox XL

To prevent confusion with press connectors of other systems, Temponox XL press connectors have four notches on the press connection.

2.4 Information for use

2.4.1 Corrosion

Protect the press connector system against excessively high concentrations of chloride generated by both the medium and by external factors.

An excessive chloride concentration can lead to corrosion in stainless steel systems.

Avoid external contact with materials containing chloride

- Insulating materials must not have a water-soluble chloride ion content that exceeds 0.05 %.
- Sound insulating inlays on the pipe clamps must not contain leachable chloride.
- Stainless steel pipes must not come into contact with building materials or mortar containing chloride.

If external corrosion protection is required, observe the pertinent guidelines, see ↗ *'Regulations from section: Corrosion' on page 5.*

3 Handling

3.1 Transport

Observe the following when transporting pipes:

- Do not pull the pipes over the sill. The surface could be damaged.
- Secure pipes during transportation. Pipes may become bent due to shifting.
- Do not damage the protective caps on the pipe ends and do not remove them until immediately before mounting. Damaged pipe ends must not be pressed.

3.2 Storage

For storage, comply with the requirements specified in the applicable regulations, see ↗ *'Regulations from section: Storage' on page 6*:

- Store components in a clean and dry place.
- Do not store the components directly on the floor.
- Provide at least three points of support for the storage of pipes.
- Where possible, store different sizes separately.
Store small sizes on top of larger sizes if separate storage is not possible.
- Store pipes of different materials separately to prevent contact corrosion.

3.3 Assembly information

3.3.1 Mounting instructions

Checking system components

System components may, in some cases, have become damaged through transportation and storage.

- Check all parts.
- Replace damaged components.
- Do not repair damaged components.
- Contaminated components may not be installed.

3.3.2 Potential equalisation



DANGER! **Danger due to electrical current**

An electric shock can lead to burns and serious injury and even death.

Because all metallic piping systems conduct electricity, unintentional contact with a live part can lead to the whole piping system and components connected to it (e. g. radiators) becoming energised.

- Only allow electrical work to be carried out by qualified electricians.
- Always integrate the metal piping system into the potential equalisation.



It is the fitter of the electrical system who is responsible for ensuring that the potential equalisation is tested and secured.

3.3.3 Permitted exchange of sealing elements



Important instruction

With their material-specific qualities, sealing elements in press connectors are adapted for use with the corresponding media and/or the areas of use of the piping systems and are generally only certified for them.

The exchange of a sealing element is generally permitted. The sealing element must be exchanged for a designated spare part for the intended application ↪ *Chapter 2.3.4 'Sealing elements' on page 12*. The use of other sealing elements is not permitted.

Exchanging a sealing element is permitted in the following situations:

- if the sealing element in the press connector is obviously damaged and should be exchanged for a Viega spare sealing element made of the same material
- if an EPDM sealing element should be exchanged for an FKM sealing element (higher thermal resistance, e.g. for industrial use)

3.3.4 Space requirements and intervals

Pressing between pipelines

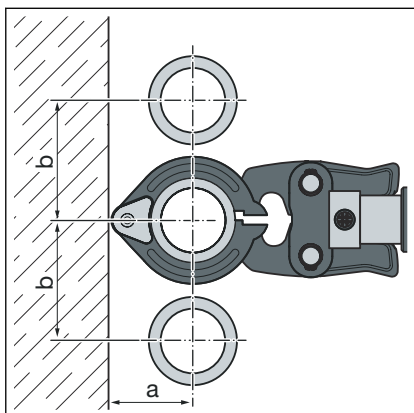

d	76.1	88.9	108.0
a [mm]	110	120	135
b [mm]	185	200	215

Pressing between pipe and wall

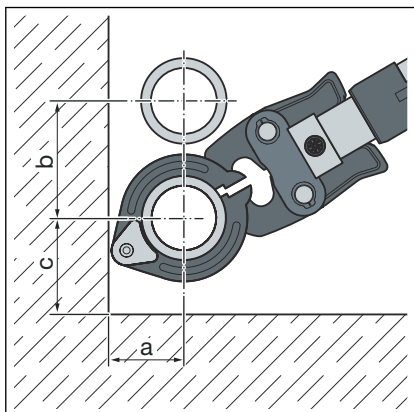

d	76.1	88.9	108.0
a [mm]	110	120	135
b [mm]	185	200	215
c [mm]	130	140	155

Wall distance

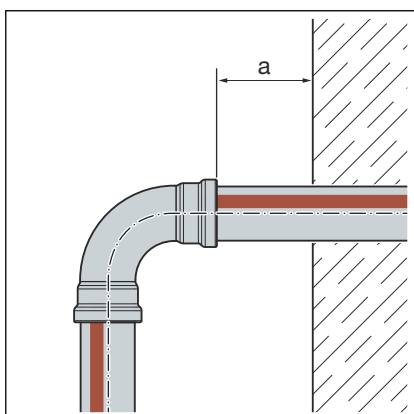

d	76.1–108.0
Minimum interval a_{min} [mm]	20

Interval between the pressings

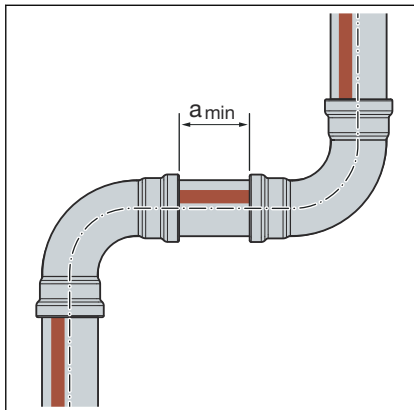

d	a _{min} [mm]
76.1	15
88.9	
108.0	

Z dimensions

For the Z dimensions, refer to the respective product page in the online catalogue.

3.3.5 Required tools

The following tools are required for production of a press connection:

- Pipe cutter or a fine-toothed hacksaw
- Deburrer and coloured pen for marking
- Press machine with constant pressing force
- Press ring with corresponding hinged adapter jaw, suitable for the pipe diameter and with suitable profile

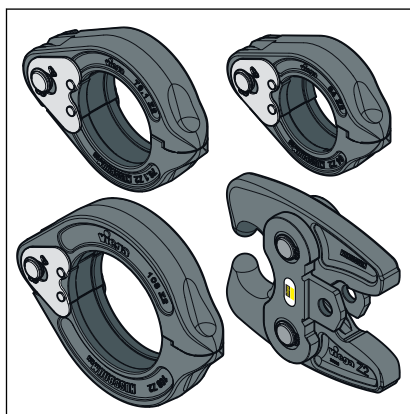

Fig. 10: Press rings and hinged adapter jaw



Viega recommends the use of Viega system tools when installing the press fittings.

The Viega system press tools have been developed and tailored specifically for the installation of Viega press connector systems.

3.4 Assembly

3.4.1 Replacing the sealing element



If the collector type (flat / vacuum tube collector) has not yet been determined at the time of laying the connection pipe to the solar-energy installation, Viega recommends using FKM sealing elements in the press connectors. Observe the chapter [Chapter 2.3.4 'Sealing elements'](#) on page 12.

Removing the sealing element



Do not use pointed or sharp-edged objects to remove the sealing element. They may damage the sealing element or the bead.

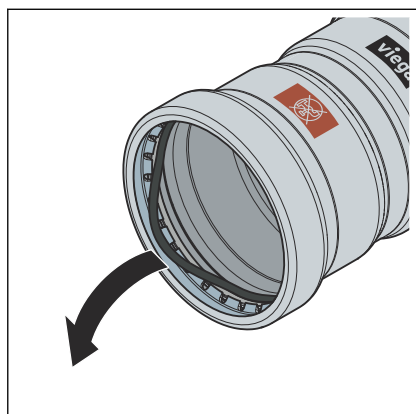

- Remove the sealing element from the bead, leaving the separator ring in the press connector.

Proceed carefully to avoid damaging the separator ring and sealing element seat.

Inserting the sealing element

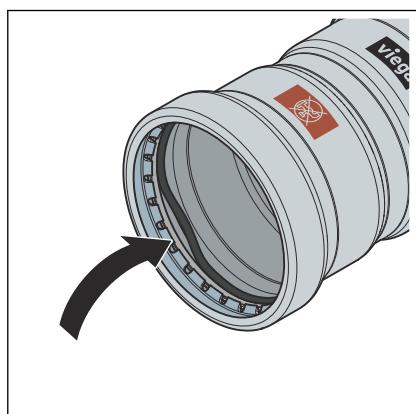

- Make sure that the sealing element is not damaged by the cutting ring.
- Ensure that the complete sealing element is in the bead.

3.4.2 Cutting pipes to length



NOTICE!
Leaking press connections due to damaged material!

Press connections can become leaky due to damaged pipes or sealing elements.

Observe the following instructions to avoid damage to pipes and sealing elements:

- Do not use cutting discs (angle grinders) or flame cutters when cutting to length.
- Do not use grease or oils (e. g. cutting oil).

For information about tools, also see [Chapter 3.3.5 'Required tools'](#) on page 19.

 Link to the video:

Cutting pipes to length

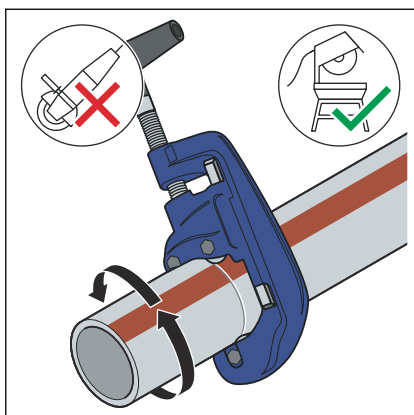

- Cut the pipe at a right angle as accurately as possible using a pipe cutter or a fine-toothed hacksaw to ensure correct and even pipe insertion depth.

Avoid grooves on the pipe surface.

3.4.3 Deburring the pipes

The pipe ends must be thoroughly deburred internally and externally after shortening.

Deburring prevents the sealing element being damaged or the that the press connector cants when mounted. Viega recommends using a deburrer (model 2292.4XL).



NOTICE!
Damage due to the wrong tool!

Do not use sanding disks or similar tools when deburring. The pipes could be damaged by these.

 Link to the video:

Deburring the pipes

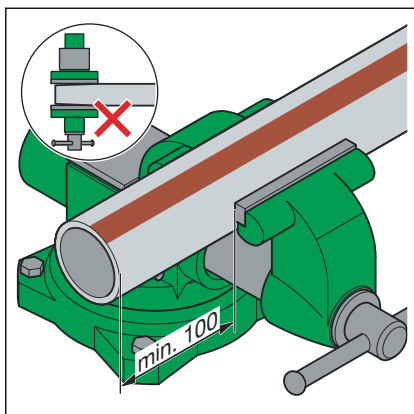

- Secure the pipe in the vice.
- When clamping, leave an interval of at least 100 mm (a) to the pipe end.
The pipe ends must not be bent or damaged.

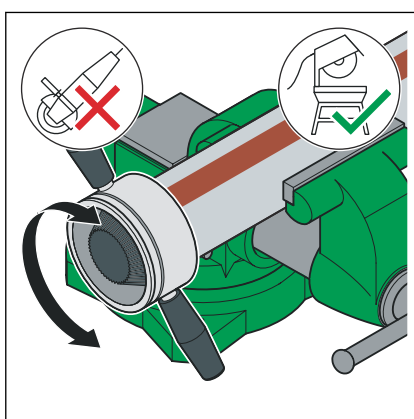

- Deburr the inside and outside of the pipe.

3.4.4 Pressing the connection

Link to the video:

Pressing the connection

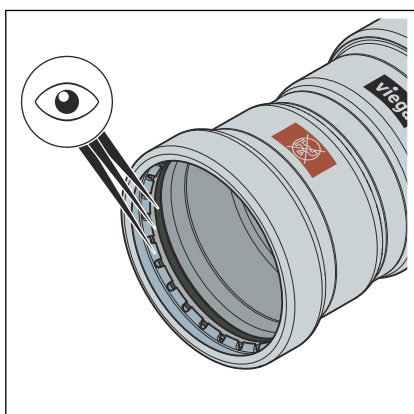

Requirements:

- The pipe end is not bent or damaged.
- The pipe is deburred.

- The correct sealing element is in the press connector.
EPDM = polished black
FKM = matt black
- Sealing element, separator ring and cutting ring are undamaged.
- Measure the insertion depth in the press connector.

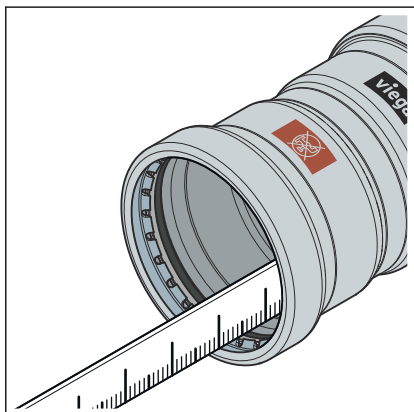

d [mm]	Insertion depth [mm]
76.1	50
88.9	50
108.0	60

- Mark the insertion depth on the pipe.

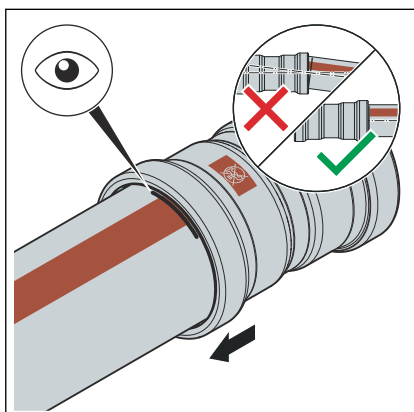

- Place the hinged adapter jaw onto the press machine and push the retaining bolt in until it clicks into place.

INFO! Observe the press tool instruction manual.

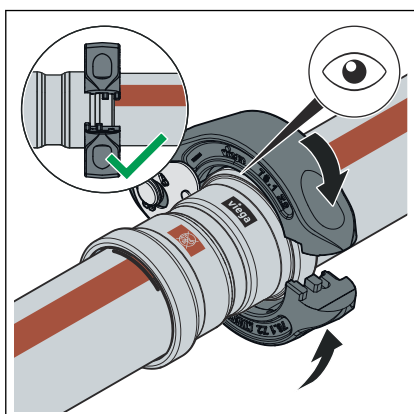

- Place the press ring onto the press connector. The press ring must completely cover the outside ring of the press connector.

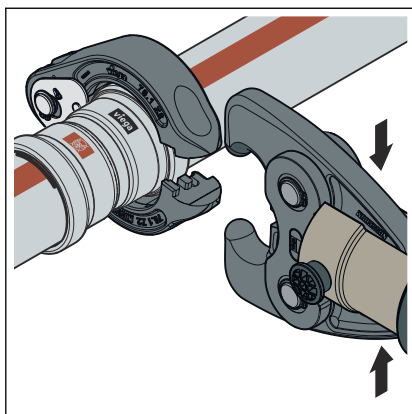

- Open the hinged adapter jaw.

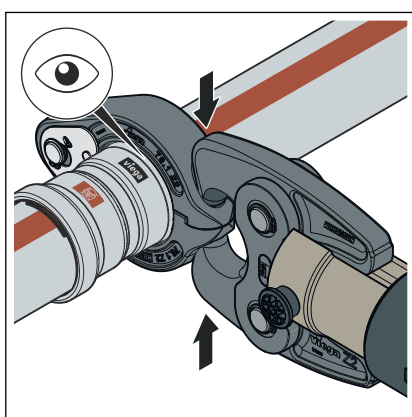

- Position the hinged adapter jaw into the seat of the press ring.
- Carry out the pressing process.
- Open the hinged adapter jaw and remove the press ring.

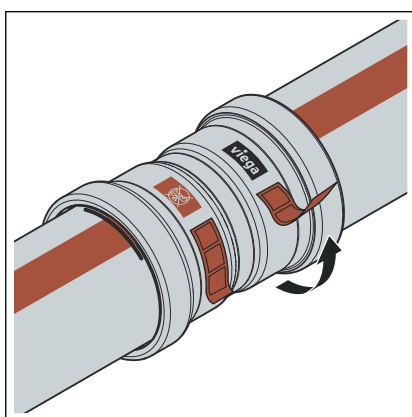

- Remove the checking strip.
- The connection is marked as having been pressed.

3.4.5 Flange connections

In the press connector system shown, flange connections in sizes 76.1 to 108.0 mm are possible.

The assembly of flange connections may only be carried out by qualified personnel. Personnel can be qualified to assemble flange connections on the basis of applicable directives, for example; see *Regulations from section: Establishing a flange connection* on page 6.

- A corresponding training section on proper flange connection assembly in vocational training (of staff/specialist personnel) with qualified completion as well as successful regular application are considered as sufficient proof.
- Other employees without the appropriate technical training (e.g. operating personnel) who are to install flange connections must be provided with technical knowledge through training measures (theoretical and practical); this must be documented.

washers

The advantages of using hardened washers are:

- Defined friction surface during assembly.
- Defined unevenness in calculation and thus reduction of the scattering of the tightening torque, whereby a greater hexagon screw force can be achieved mathematically.

Flange types

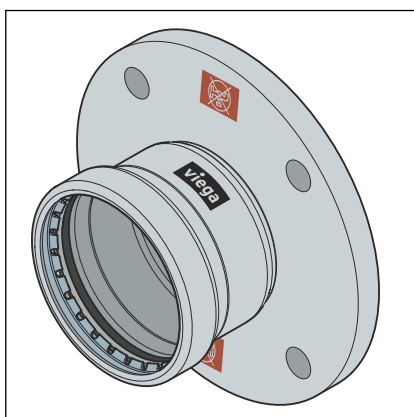

Fig. 11: Fixed flange 1759.1XL

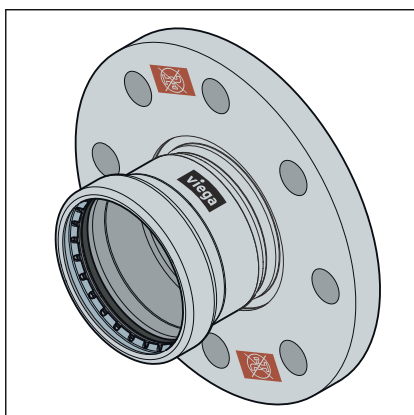

Fig. 12: Fixed flange 1759XL

Fixed flange

- Steel, stainless
- Press connection made of stainless steel
- Model 1759XL: 76.1 to 108.0 mm (PN10/16)
- Model 1759.1XL: 76.1 to 108.0 mm (PN6)

Establishing a flange connection



Always make the flange connection first and then the press connection.

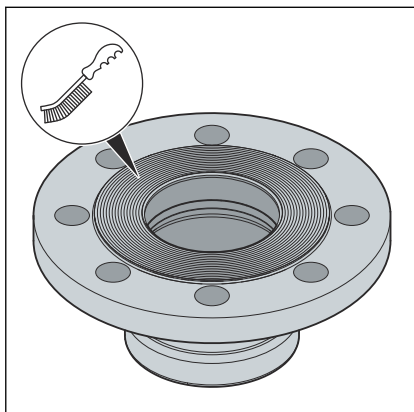

- If necessary, remove any temporary coatings on the flange sealing surfaces without leaving any residue before assembly, using cleaning agents and a suitable wire brush.

NOTICE! When replacing seals, make sure to remove the old seal completely from the flange sealing surface without damaging the flange sealing surface.

- Ensure that the flange sealing surfaces are clean, undamaged and even. In particular, there must not be any radial surface damage such as grooves or impact marks.

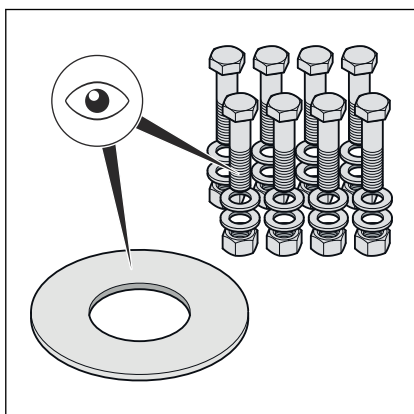

- The hexagon screws, nuts and washers must be clean and undamaged and comply with the specifications for minimum hexagon screw length and strength class, see **'Required tightening torques'** on page 29.

- During disassembly, replace removed hexagon screws, nuts and washers with new ones if damaged.

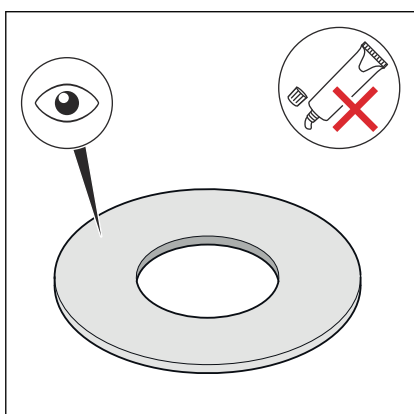

- The seal must be clean, undamaged and dry. Do not use adhesives and assembly pastes for seals.
- Do not reuse used seals.
- Do not use seals with kinks as they pose a safety risk.
- Ensure that seals are free from faults and defects and that the manufacturer's specifications are complied with.

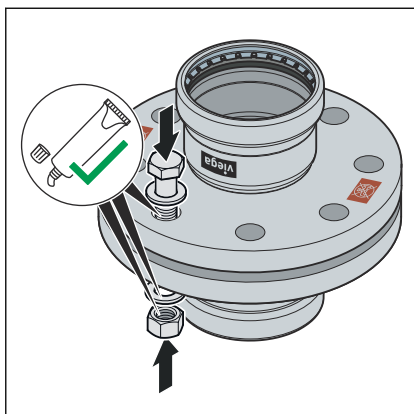

► Lubricate the following flange elements with suitable lubricant:

- Hexagon screw thread
- Washer
- Nut support

NOTICE! Observe the manufacturer's information on the application and temperature range of the lubricant.

Install and centre the sealing element

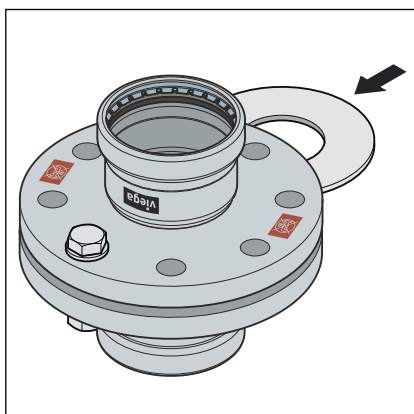

The correct assembly of flange connections requires parallel aligned flange blades without an offset centre that allow the sealing element to be inserted in the correct position without damage.

► Press the sealing surfaces far enough apart so that the seal can be inserted without force and without damage.

The gap (out-of-parallelism of the sealing surfaces) before tightening the hexagon screws is not critical if the permissible gap is not exceeded.

DN	Permissible gap a-b [mm]
65–100	0.6

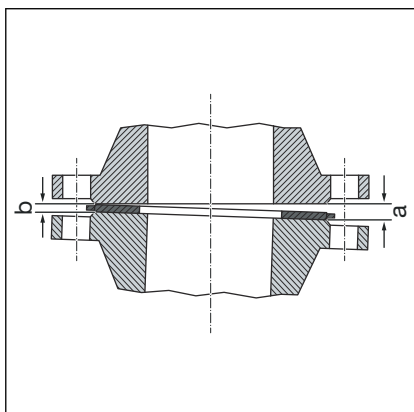

► Remove the gap from the gaping side (a).

► In case of doubt, tighten the flanges without inserting a seal by tightening the hexagon screws to achieve parallelism and a sealing surface distance of approx. 10 % of the nominal torque.

□ The gap is not permissible if the flange position cannot be achieved without great effort.

Systematics for tightening hexagon screws

- The order in which the hexagon screws and nuts are tightened has a significant influence on the force distribution acting on the seal (surface pressure). Incorrect tightening leads to a high dispersion of the pretensioning forces and can result in the required minimum surface pressure not being reached and even in leaks.
- After tightening the nut, at least two but no more than five threads should protrude from the end of the hexagon screw.

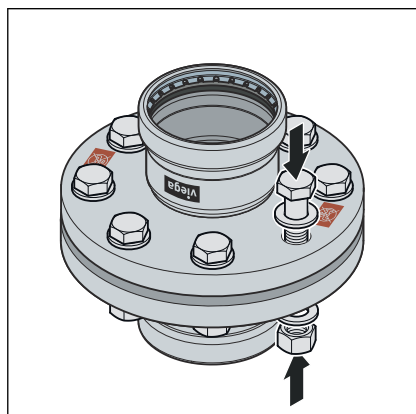

- Prepare the hexagon screws by hand, observing the following:
 - Install the hexagon screws so that all the hexagon screw heads are on one flange side.
 - For horizontally arranged flanges, insert the hexagon screws from above.
 - Replace stiff hexagon screws with easy-running ones.

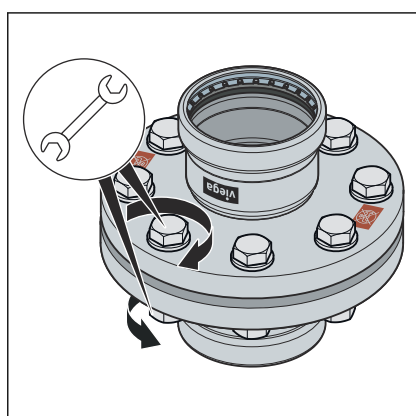

- The simultaneous use of several tightening tools is possible.

Suit order

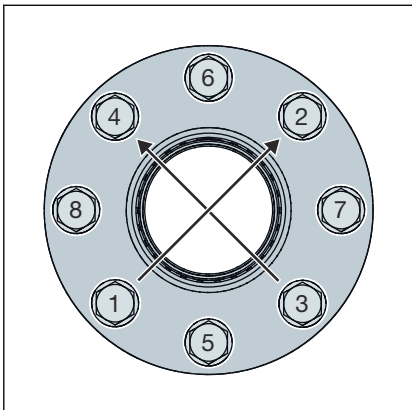

Fig. 13: Model 1159XL

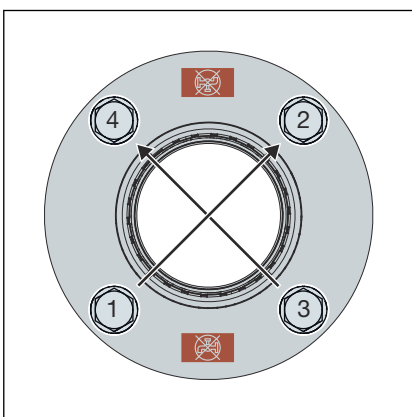

Fig. 14: Model 1759 XL

- Tighten all hexagon screws crosswise with 30 % of the nominal tightening torque.
- Tighten all hexagon screws as described in step 1 with 60 % of the nominal tightening torque.
- Tighten all hexagon screws as described in step 1 with 100 % of the nominal tightening torque.
- Tighten all hexagon screws again with the full nominal tightening torque. Repeat this process until the nuts can no longer be turned when the full tightening torque is applied.

Required tightening torques

Tightening torques for Temponox XL flange adapters PN 6

Model	DN	Article number	Thread	Min. required tightening torque [Nm]	Max. permissible tightening torque [Nm]	Hexagon screw length (mm)	Strength class
1759.1 XL	65	811 259 ¹	M12	34	57	50	A2 - 70
	80	811 266 ¹	M16	56	142	60	
	100	811 273 ²		65	142		

The specifications for meeting the requirements of tightness class L0,01 (TA Luft) were calculated according to the applicable standard and apply exclusively when using Viega articles; see also 1759.1XL ↗ 'Regulations from section: Establishing a flange connection' on page 6.

¹For use with mounting set article number 816568

²For use with mounting set article number 816575

Tightening torques for Temponox XL flange adapters PN 10/16

Model	DN	Article number	Thread	Min. required tightening torque [Nm]	Max. permissible tightening torque [Nm]	Hexagon screw length (mm)	Strength class
1759 XL	65	811 174 ¹	M16	51	114	70	A2 - 70
	80	811 181 ¹		64	144		
	100	811 198 ¹		134	144		

The specifications for meeting the requirements of tightness class L0,01 (TA Luft) were calculated according to the applicable standard and apply exclusively when using Viega articles; see also  'Regulations from section: Establishing a flange connection' on page 6.

¹For use with mounting set article number 583682

Disconnecting the flange adapter

Before starting to disassemble an existing flange connection, get approval and a work permit from the responsible company, if necessary, observing the following:

- The system section must be depressurised and completely flushed.
- Secure built-in or attached parts that are not held separately before loosening the flange connection. This also applies to fastening systems such as spring hangers and supports.
- Start loosening hexagon screws or nuts on the side facing away from the body, loosen the remaining hexagon screws slightly and only disassemble completely when you have ensured that the piping system does not present a risk. If a pipeline is under tension, there is a risk of the pipeline rupturing.
- Loosen the hexagon screws or nuts crosswise in at least two passes.
- Close open ends of strands with dummy plugs.
- Transport disassembled pipelines only in closed condition.
- When replacing seals, make sure to remove the old seal completely from the flange sealing surface without damaging the flange sealing surface.



NOTICE!

Caution when using an angle grinder!

When loosening defective hexagon screws and nuts with the help of an angle grinder, sparks are produced that can burn into the pipe material and cause corrosion.

3.4.6 Leakage test

 Link to the video:

Leakage test

The installer must perform a leakage test before commissioning.

Carry out this test on a system that is finished but not covered yet.

Observe the applicable regulations, see  *'Regulations from section: Leakage test' on page 6.*

Also carry out the leak test for non-potable water installations in accordance with the applicable guidelines, see  *'Regulations from section: Leakage test' on page 6.*

Document the result.

3.5 Disposal

Separate the product and packaging materials (e. g. paper, metal, plastic or non-ferrous metals) and dispose of in accordance with valid national legal requirements.



Viega GmbH & Co. KG
service-technik@viega.de
viega.com

INT • 2024-08 • VPN230442

