

Instructions for Use

Urinal flush plate for Prevista Visign for Public 11



for urinal flushing systems

Model
8631.2

Year built (from)
03/2019

viega

Table of contents

1	About these instructions for use	3
	1.1 Target groups	3
	1.2 Labelling of notes	3
	1.3 About this translated version	4
2	Product information	5
	2.1 Standards and regulations	5
	2.2 Intended use	5
	2.2.1 Areas of application	5
	2.2.2 Maintenance	5
	2.3 Product description	6
	2.3.1 Overview	6
	2.3.2 Technical data	6
3	Handling	7
	3.1 Assembly information	7
	3.1.1 Required material and tools	7
	3.2 Assembly	7
	3.2.1 Insert cartridge valve	7
	3.2.2 Mounting the flush plate	10
	3.3 Errors, faults and remedy	14
	3.4 Care and maintenance	14
	3.4.1 Care tips	14
	3.4.2 Cleaning cartridge valve	14
	3.5 Disposal	17

1 About these instructions for use

Trade mark rights exist for this document; for further information, go to viega.com/legal.

1.1 Target groups

The information in this instruction manual is directed at the following groups of people:

- Heating and plumbing experts and trained personnel
- Consumers

Individuals without the above-mentioned training or qualifications are not permitted to mount, install or, if appropriate, maintain this product. This restriction does not extend to possible operating instructions.

The installation of Viega products must take place in accordance with the generally accepted rules of engineering and the Viega instructions for use.

1.2 Labelling of notes

Warning and advisory texts are set aside from the remainder of the text and are labelled with the relevant pictographs.



DANGER!

This symbol warns of possible life-threatening injury.



WARNING!

This symbol warns of possible serious injury.



CAUTION!

This symbol warns of possible injury.



NOTICE!

This symbol warns of possible damage to property.



This symbol gives additional information and hints.

1.3 About this translated version

This instruction for use contains important information about the choice of product or system, assembly and commissioning as well as intended use and, if required, maintenance measures. The information about the products, their properties and application technology are based on the current standards in Europe (e.g. EN) and/or in Germany (e.g. DIN/DVGW).

Some passages in the text may refer to technical codes in Europe/Germany. These should serve as recommendations in the absence of corresponding national regulations. The relevant national laws, standards, regulations, directives and other technical provisions take priority over the German/European directives specified in this manual: The information herein is not binding for other countries and regions; as said above, they should be understood as a recommendation.

2 Product information

2.1 Standards and regulations

The following standards and regulations apply to Germany / Europe and are provided as a support feature.

Regulations from section: Technical data

Scope / Notice	Regulations applicable in Germany
Flush flow	DIN 3265
Noise class	DIN 4109

2.2 Intended use

2.2.1 Areas of application

The urinal flush plate is intended for the actuation of flushes in urinals.

2.2.2 Maintenance

The cartridge valve should be cleaned once a year to ensure fault-free operation. See [Chapter 3.4.2 'Cleaning cartridge valve' on page 14](#)

2.3 Product description

2.3.1 Overview

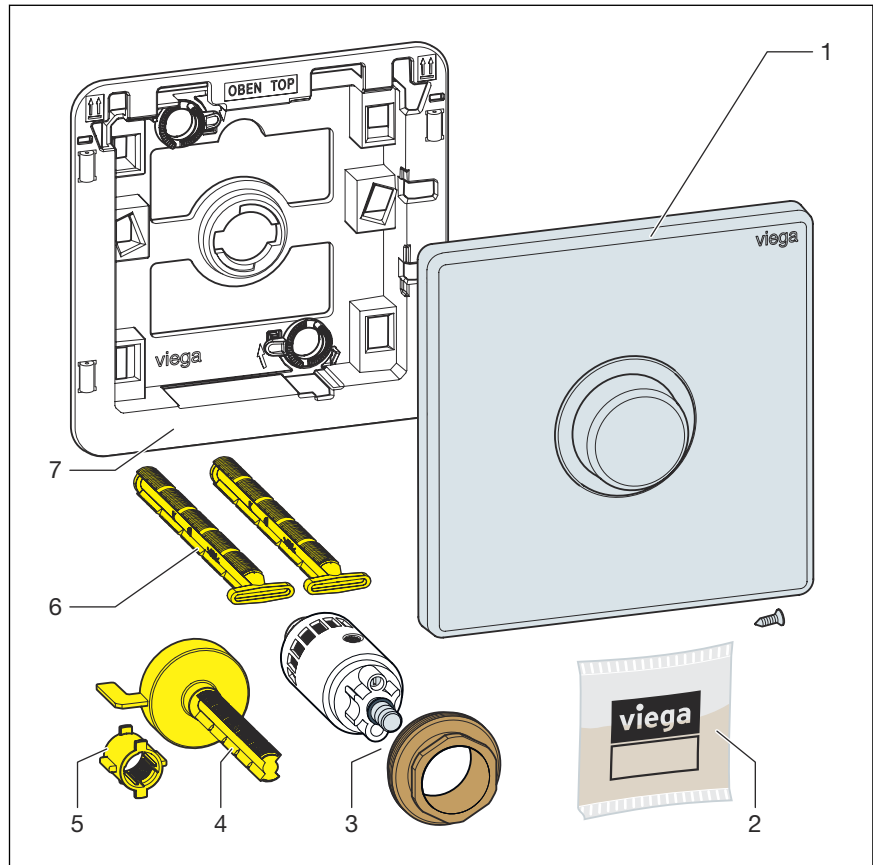

Fig. 1: Scope of delivery

- 1 Flush plate
- 2 Silicon grease
- 3 Cartridge valve
- 4 Actuator
- 5 Sleeve
- 6 Retaining bolt
- 7 installation frame

2.3.2 Technical data

The product has the following technical data:

Minimum flow pressure	0.05–0.5 MPa (0.5–5 bar)
Flush flow, see ↗ 'Regulations from section: Technical data' on page 5	0.3–0.7 l/s
Noise class, see ↗ 'Regulations from section: Technical data' on page 5	Class 2

3 Handling

3.1 Assembly information

3.1.1 Required material and tools

Tool

The following tools are required for mounting:

- cutting knife

3.2 Assembly

3.2.1 Insert cartridge valve

Requirements:

- The pre-wall element has been mounted.
- The tiling work is completed.
- The revision opening is freely accessible.
- The urinal ceramic has been mounted.
- Cut into the sticky tape of the shaft cover.



- Remove the shaft cover.



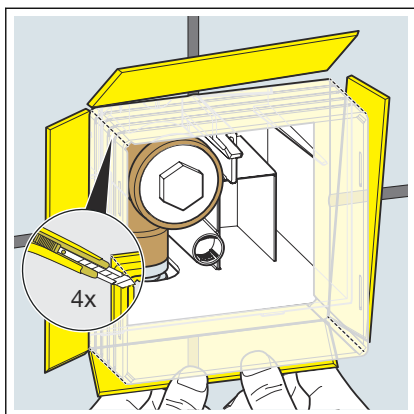

- Cut into the corners of the revision shaft.
- Fold the sides of the revision shaft outwards up to the tile level and snap them off.

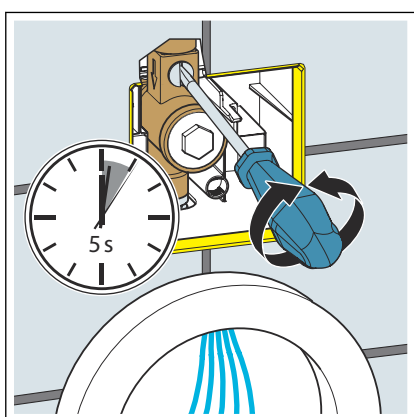

- Open the shut-off with a screwdriver for a few seconds to rinse the pipeline.
- Re-close the shut-off.

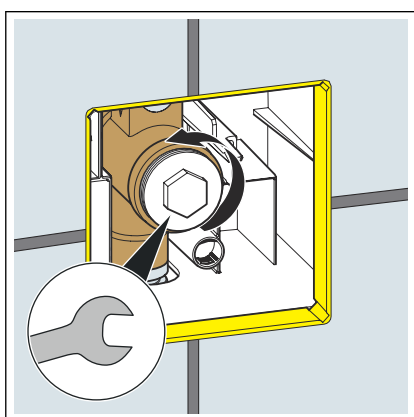

- Remove the seal.

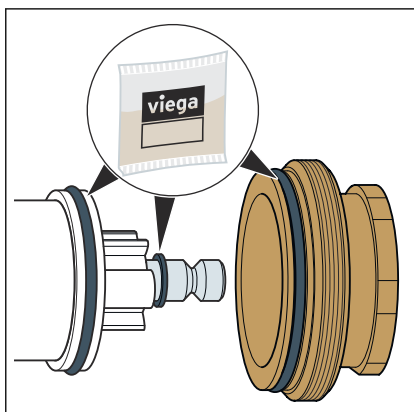

- Grease the sealing elements.

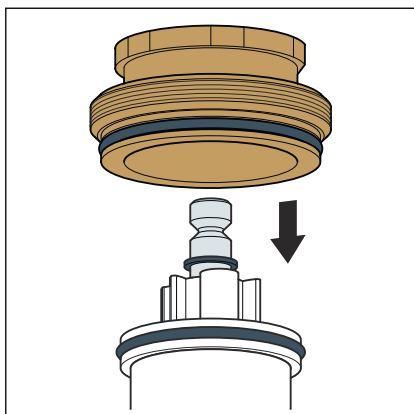

- Place the brass nut on the cartridge valve.

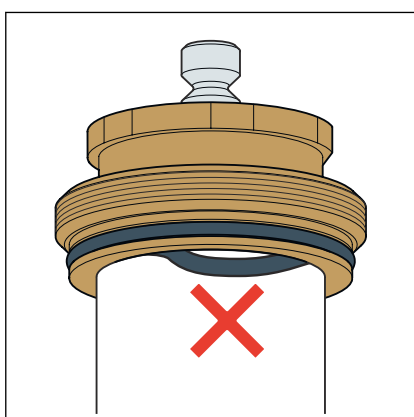

INFO! Check that the sealing element is properly positioned.

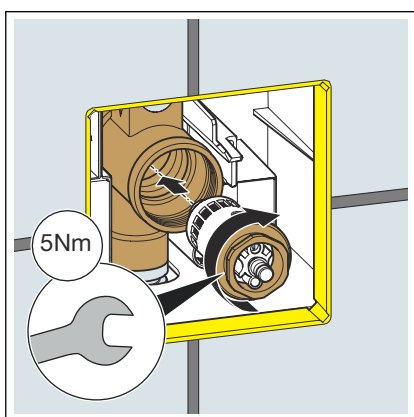

- Place the cartridge valve on straight and carefully screw in (fine thread).
Tightening torque: 5 Nm
- Screw in the cartridge valve (size 27).

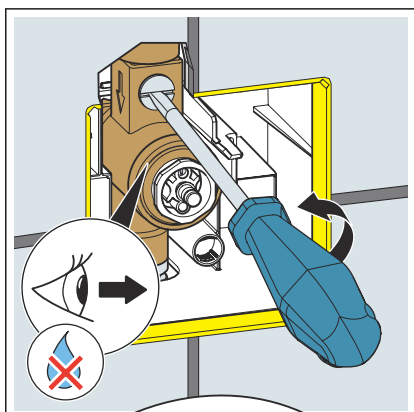

- Open the shut-off valve.
- Checking for leak tightness.

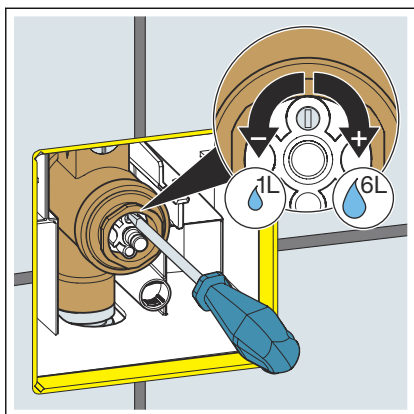

- Set the flush volume.
Setting range 1 l to 6 l

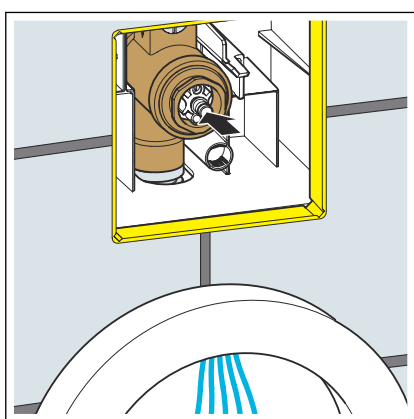

- Actuate a flushing and check the set flush volume.
- Re-set the flush volume if applicable.

3.2.2 Mounting the flush plate

Requirements:

- The cartridge valve is mounted and set.
- Insert the actuator.
Observe proper alignment.
- Apply the installation frame.

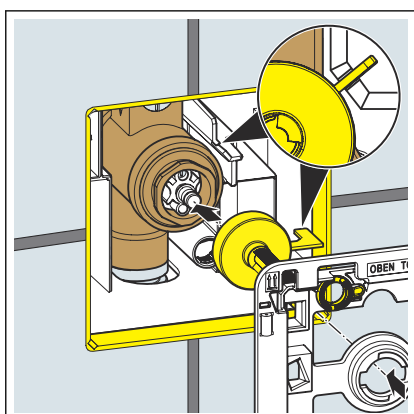

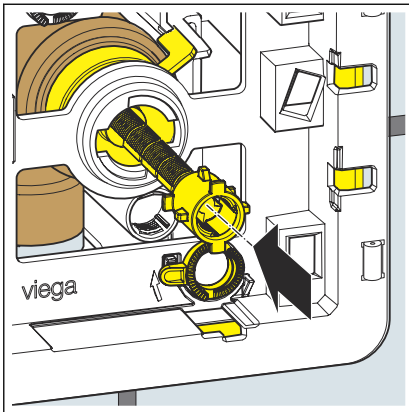

► Place the sleeve over the actuator.

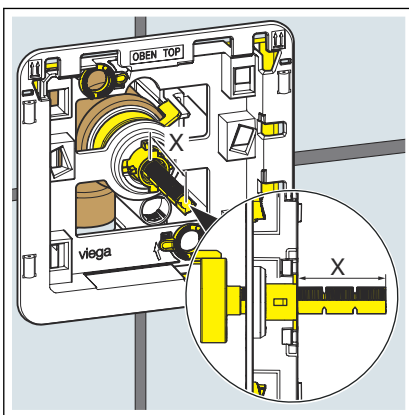

► Measure the actuator.

INFO! The actuator must not protrude over the sleeve.

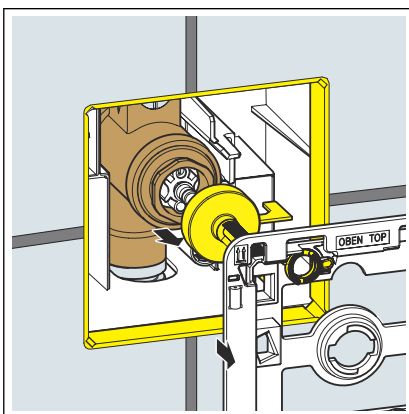

► Take the installation frame and actuator off again.

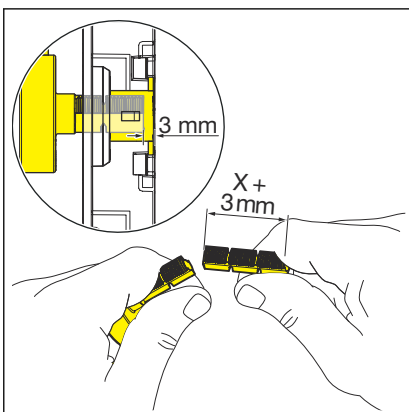

► Cut the actuator to length.

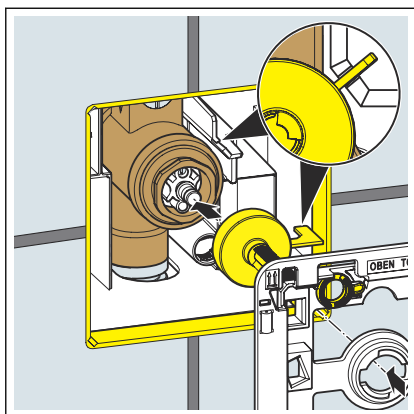

- Insert the actuator.
Observe proper alignment.
- Apply the installation frame.

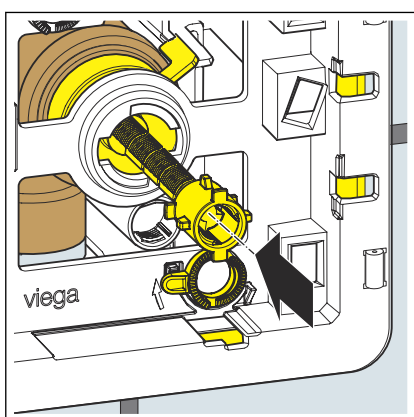

- Place the sleeve over the actuator.

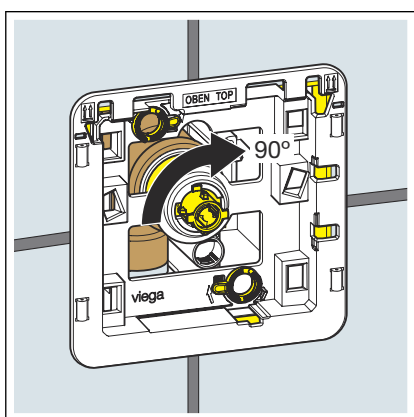

- Secure the sleeve with a 90° clockwise turn.

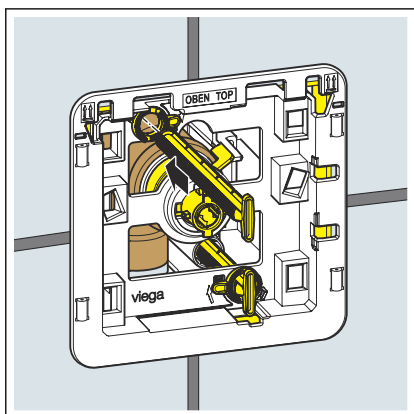

- Slide the retaining bolt in.
- If necessary, remove the retaining bolts again and cut the segments to length.
- Slide the retaining bolt in as far as it will go.

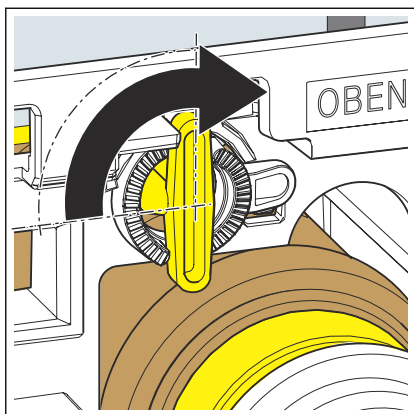

- Align the installation frame.
- Turn the retaining bolts by 90° in a clockwise direction.

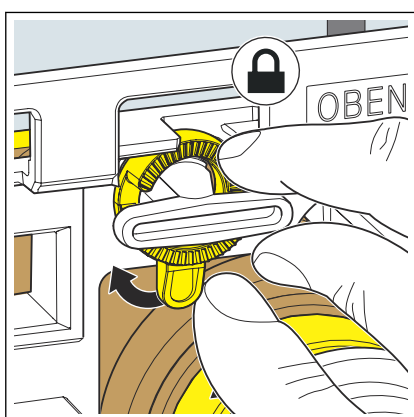

- To fix the retaining bolts, turn safety rings in a clockwise direction.

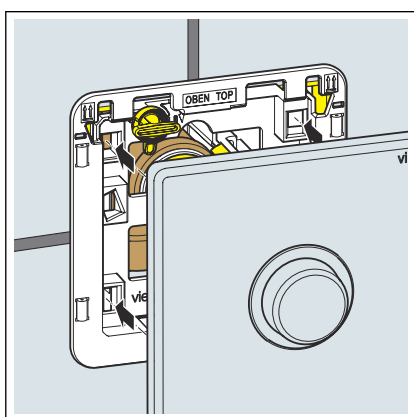

- Mount the flush plate.

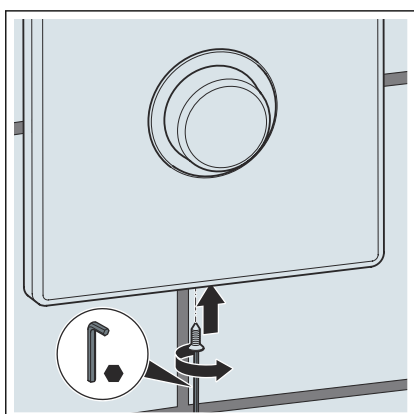

- Screw on the flush plate with an Allen key (size 2).
- The flush plate is mounted.

3.3 Errors, faults and remedy

Fault	Cause	Solution
The urinal does not flush.	The shut-off valve closed.	Open the shut-off valve.
	The cartridge valve dirty or damaged.	Clean the cartridge valve, if necessary replace it. ☞ Chapter 3.4.2 'Cleaning cartridge valve' on page 14
The flush is too weak.	The shut-off valve is not open far enough.	Open the shut-off valve.
	The cartridge valve dirty or damaged.	Clean the cartridge valve, if necessary replace it. ☞ Chapter 3.4.2 'Cleaning cartridge valve' on page 14
The urinal flush runs through.	The cartridge valve dirty or damaged.	Clean the cartridge valve, if necessary replace it. ☞ Chapter 3.4.2 'Cleaning cartridge valve' on page 14

3.4 Care and maintenance

3.4.1 Care tips

Use normal soap or a mild cleaning agent for regular care and prevention of lime scale on the flush plate. Under no circumstances should scouring agent or scratching objects be used.

Strong stains can be removed using typical household cleaner. Rinse the detergent thoroughly with clear water after the prescribed exposure time. There should be no residue on the components.

3.4.2 Cleaning cartridge valve

Clean the cartridge valve if necessary. Proceed as follows:

- Remove the flush plate with an Allen key (size 2).

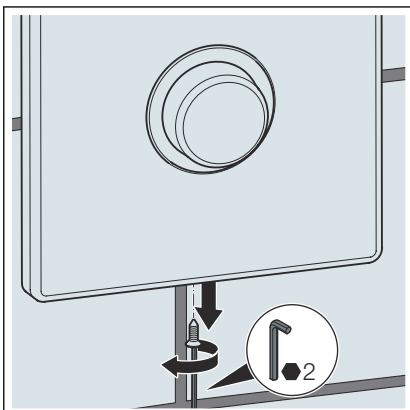

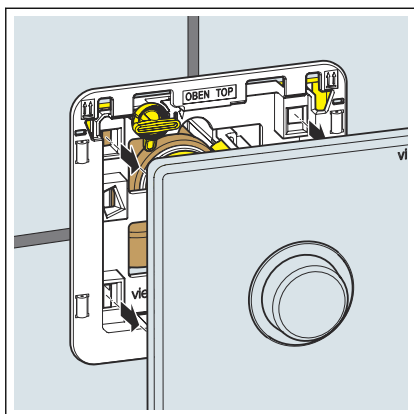

➤ Remove the flush plate from the installation frame.

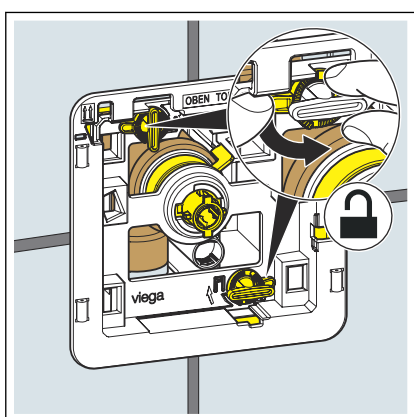

➤ Turn the safety rings 90° anti-clockwise.
Hold the retaining pins in position.

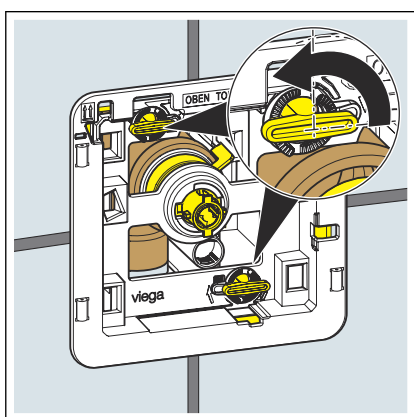

➤ Turn the retaining bolts 90° anti-clockwise.

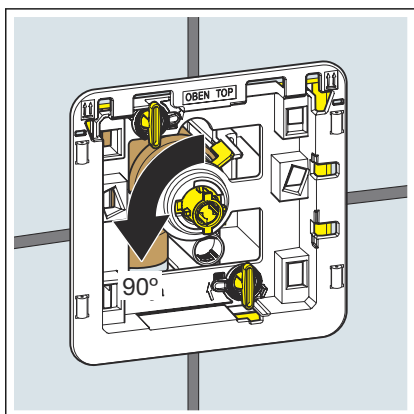

➤ Turn the sleeve 90° anti-clockwise to unlatch it.

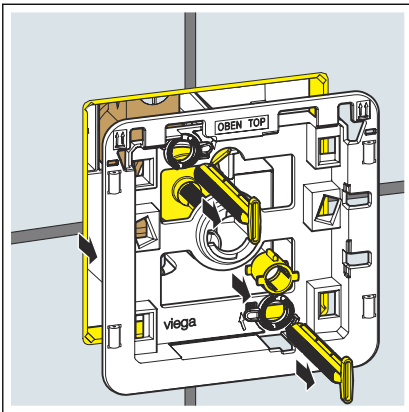

- Loosen the installation frame.

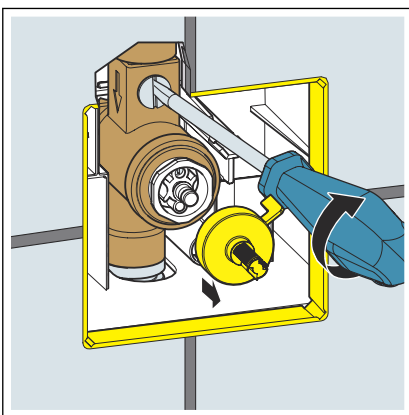

- Close the shut-off.
- Remove the actuator.

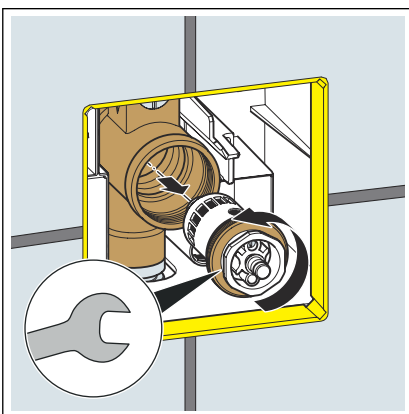

- Unscrew the cartridge valve.

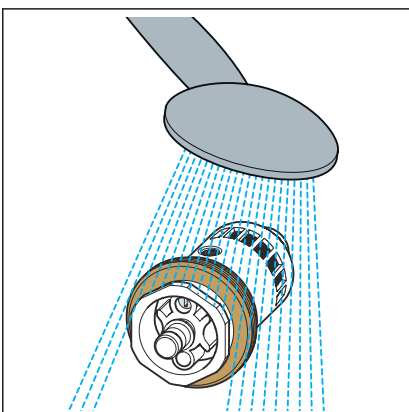

- Rinse the cartridge valve under running water.
Remove coarse dirt with a soft brush.
- Re-mount the cartridge valve and the flush plate in accordance with [Chapter 3.2.1 'Insert cartridge valve' on page 7.](#)

3.5 Disposal

Separate the product and packaging materials (e. g. paper, metal, plastic or non-ferrous metals) and dispose of in accordance with valid national legal requirements.



Viega GmbH & Co. KG
service-technik@viega.de
viega.com

INT • 2022-08 • VPN200439

