

Instructions for Use

Advantix Cleviva shower channel profile

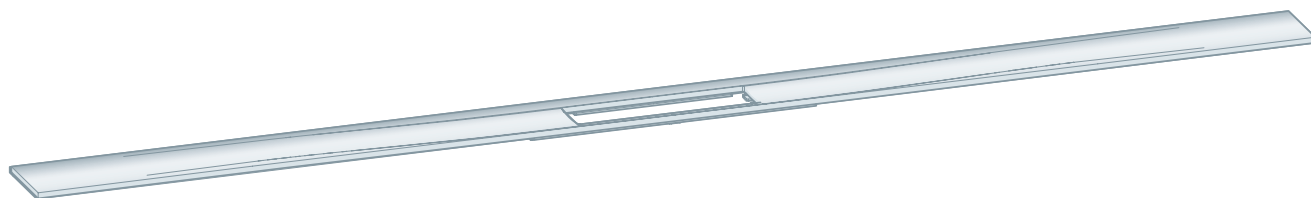

for Advantix Cleviva shower channel base unit

Model
4981.32

viega

Table of contents

1	About these instructions for use	3
	1.1 Target groups	3
	1.2 Labelling of notes	3
	1.3 About this translated version	4
2	Product information	5
	2.1 Intended use	5
	2.1.1 Areas of use	5
	2.1.2 Media	5
	2.2 Required accessories	5
3	Assembly	6
	3.1 Installation dimensions	6
	3.2 Installation in tiled floors	7
	3.2.1 Mounting height adjustment piece and shower channel profile	7
	3.3 Installation in self-levelling coating	15
	3.3.1 Sealing the shower channel	15
	3.3.2 Mounting height adjustment piece and shower channel profile	17
4	Care	24
	4.1 Care tips	24
5	Disposal	25

1 About these instructions for use

Trade mark rights exist for this document; for further information, go to viega.com/legal.

1.1 Target groups

The information in this instruction manual is directed at the following groups of people:

- Heating and plumbing experts and trained personnel

Individuals without the abovementioned training or qualification are not permitted to mount, install and, if required, maintain this product. This restriction does not extend to possible operating instructions.

The installation of Viega products must take place in accordance with the general rules of engineering and the Viega instructions for use.

1.2 Labelling of notes

Warning and advisory texts are set aside from the remainder of the text and are labelled with the relevant pictographs.



DANGER!

This symbol warns of possible life-threatening injury.



WARNING!

This symbol warns of possible serious injury.



CAUTION!

This symbol warns of possible injury.



NOTICE!

This symbol warns of possible damage to property.



This symbol gives additional information and hints.

1.3 About this translated version

This instruction for use contains important information about the choice of product or system, assembly and commissioning as well as intended use and, if required, maintenance measures. The information about the products, their properties and application technology are based on the current standards in Europe (e.g. EN) and/or in Germany (e.g. DIN/DVGW).

Some passages in the text may refer to technical codes in Europe/Germany. These should serve as recommendations in the absence of corresponding national regulations. The relevant national laws, standards, regulations, directives and other technical provisions take priority over the German/European directives specified in this manual: The information herein is not binding for other countries and regions; as said above, they should be understood as a recommendation.

2 Product information

2.1 Intended use

2.1.1 Areas of use

The Advantix Cleviva shower channel is intended for mounting on a Advantix Cleviva shower channel base unit.

2.1.2 Media

- The short-term temperature of the wastewater may reach up to 95 °C. The temperature must be considerably lower in constant operation.
- The pH value must be higher than 4 but lower than 10.

It is not permitted to introduce wastewater which would damage the product material.

2.2 Required accessories

For the complete assembly an Advantix Cleviva height adjustment piece (model 4981.84) and a shower channel insert (model 4981.50 or 4981.60) are required.

3 Assembly

3.1 Installation dimensions

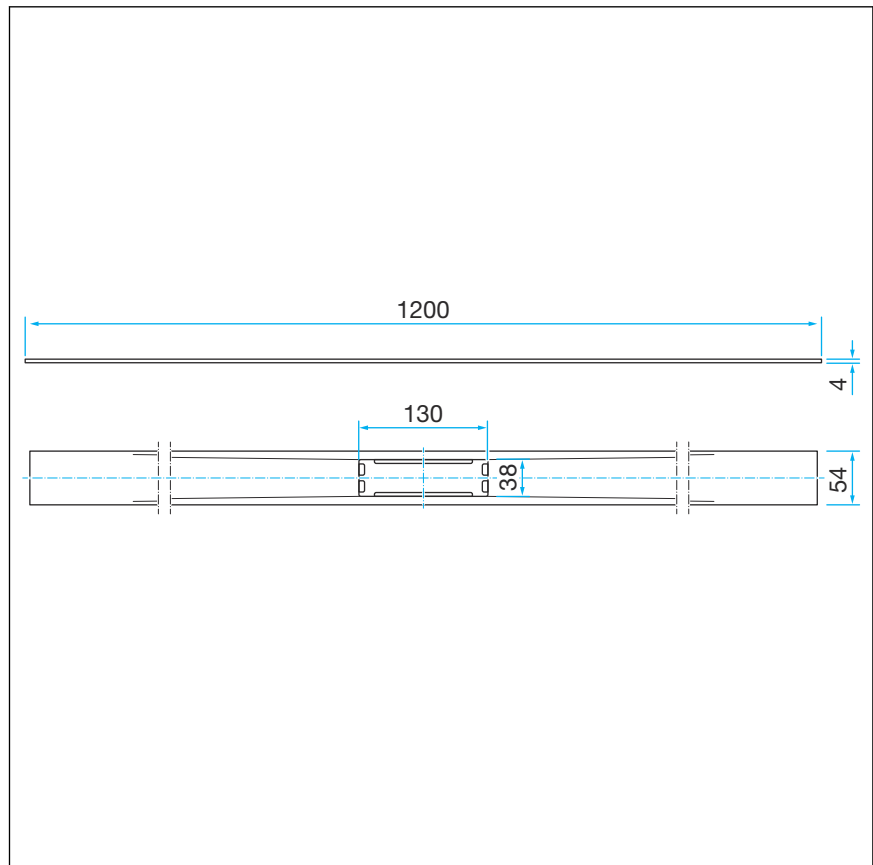

Fig. 1: Dimensions

3.2 Installation in tiled floors

3.2.1 Mounting height adjustment piece and shower channel profile

Determining dimensions



The shower channel profile can be shortened.

Coloured profiles can be likewise shortened. When the coloured profile (PVD-coated) is shortened, the stainless steel base material is visible at the cut edges. Mount the shortened profile so that the cut edge is not visible.

The shower channel profile is divided into two drain zones.

- 1 Drain zone (flat, no incline)
- 2 Drain zone (with contour, 1–2 % incline)

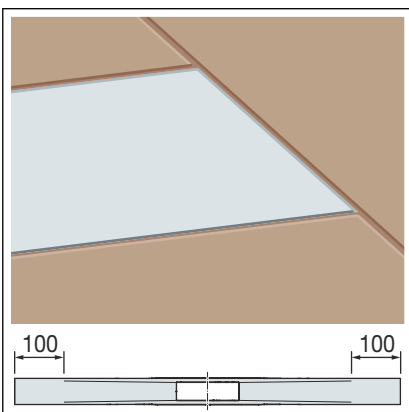
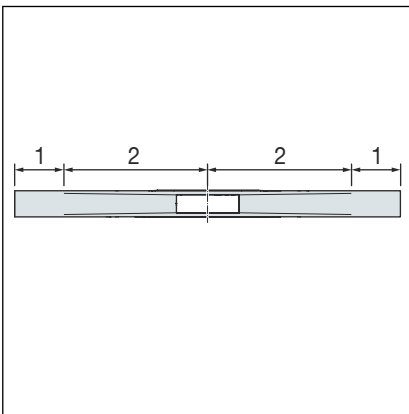

The shower channel profile can be shortened by up to 100 mm at the ends of the drain zone.

To be able to achieve individual profile lengths, the shower channel profile and the tiles are at the same height.

Shortening range of drain zone

Profile length	Shortening range
800 mm	600–800 mm
1000 mm	800–1000 mm
1200 mm	1000–1200 mm

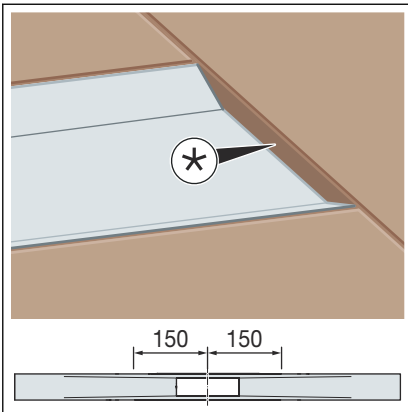

* Offset between shower channel profile and tile

In the drain zone, the shower channel profile can be shortened to a minimum installation length of 150 mm from centre of the drain.

The resultant offset between the shower channel profile and the tile can be closed with a tile end rail or with silicon.



If channel solutions >1200 mm are required, the standard lengths of 800, 1000 and 1200 mm can be combined with one another.

To avoid an offset when laying several profiles, shorten the profiles only at the drain zone (max. 100 mm).

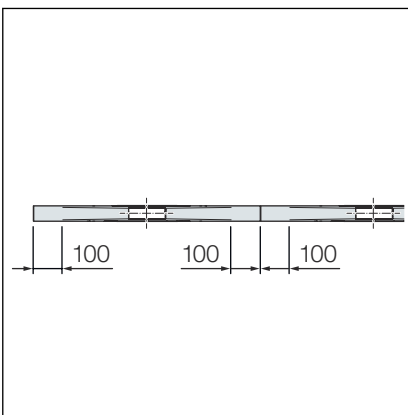

Shortening range of drain zone for extended shower channel profiles

Profile length	Shortening range
2 x 800 mm	1200–1600 mm
2 x 1000 mm	1600–2000 mm
2 x 1200 mm	2000–2400 mm

Shortening the shower channel profile

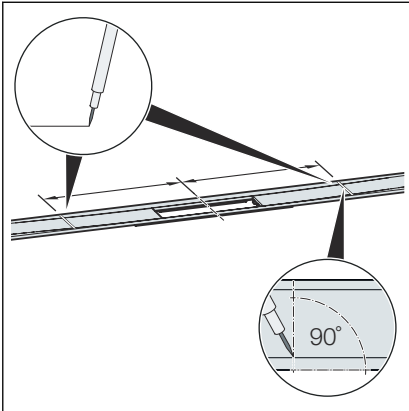

- Determine the required dimension and mark at right angles.

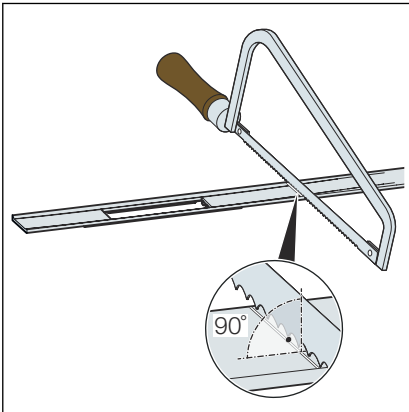

- Using a handsaw, shorten the shower channel profile at right angles and deburr.

Alternatively, the shower channel profile can be shortened using an electric metal slitting disc or a speed-restricted angle grinder with suitable stainless steel slitting disc.

NOTICE! To prevent corrosion, the tools must not have been used beforehand for processing ferrous materials.

Mounting the shower channel profile

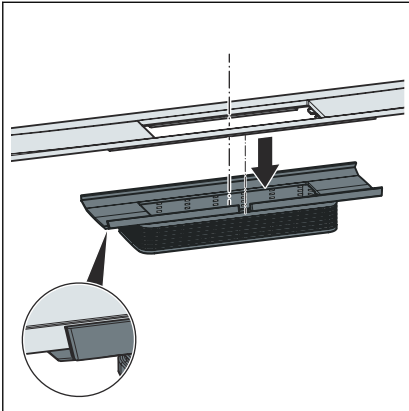

- Insert the shower channel profile into the height adjustment piece as far as it will go.

Make sure that shower channel profile protrusion sits exactly in the recess of the height adjustment piece.

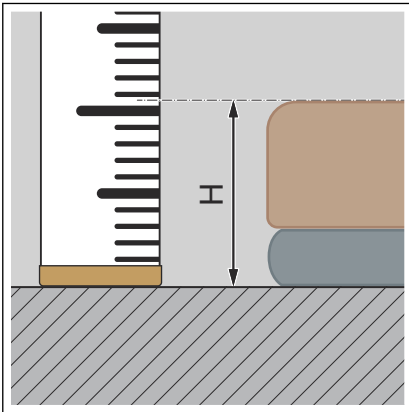

- Determine the flooring height H.

INFO! For fault-free drainage, Viega recommends laying the floor covering 1–2 mm higher than the shower channel profile.

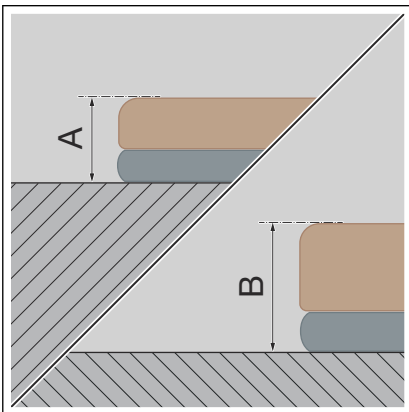

- Due to the stepless shortening of the top, an installation height of at least A 12 mm to B 30 mm is possible for tiles and tile adhesive.

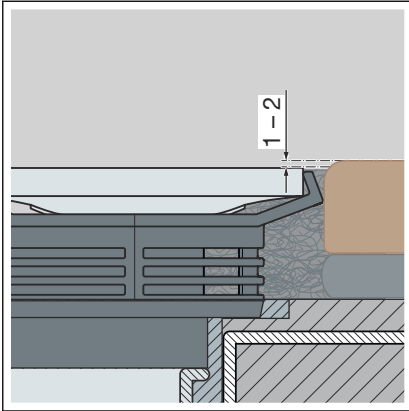

- Lay the floor covering 1–2 mm higher than the shower channel profile.

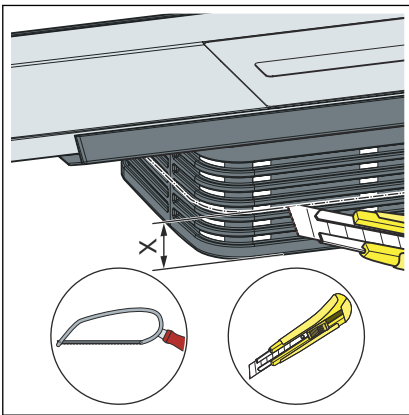

- Dimension $X = 30 \text{ mm} - H$
Shorten dimension X along the cutting aid and deburr.

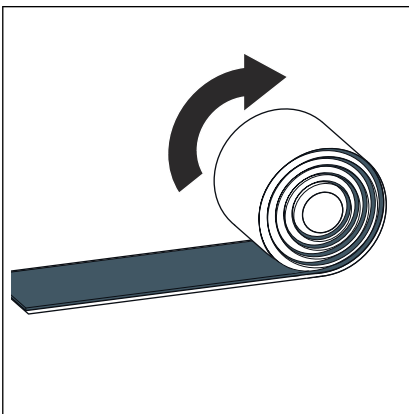

- Unroll the butyl tape and cut to size.

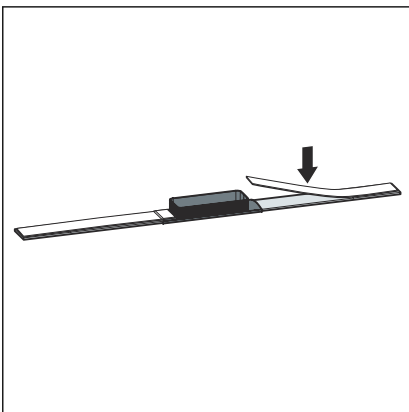

- Stick the butyl tape centrally on the underside of the shower channel profile.

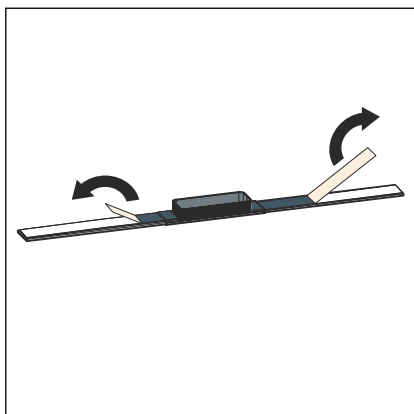

- Remove the protective foil.

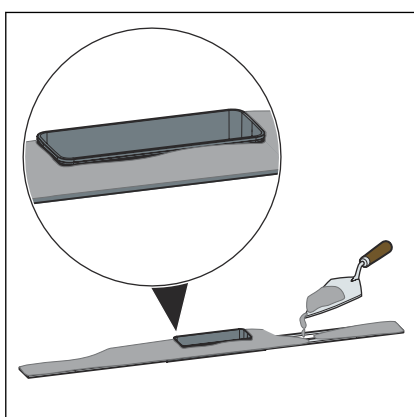

NOTICE! The flexural strength of the tile adhesive must conform to at least Class S1.

- Apply the tile adhesive over the entire underside of the shower channel profile and the height adjustment piece.

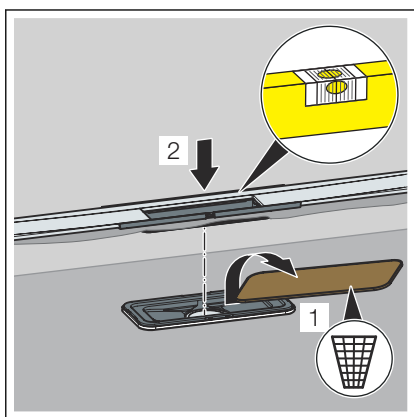

- Remove the wooden site protection.
Do not damage the bonded sealing.
- Insert the shower channel profile and the height adjustment piece.

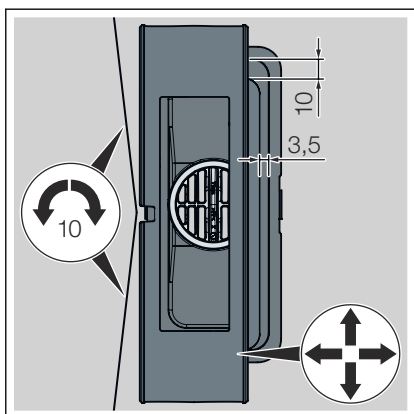

- Align the shower channel profile and the height adjustment piece horizontally.
 - The shower channel profile can be radially rotated by max. 10 mm (with a 1200 mm shower channel profile).
 - To adjust the shower profile to the tile pattern, the height adjustment piece can be moved on the long side by 3.5 mm and on the head side by 10 mm.

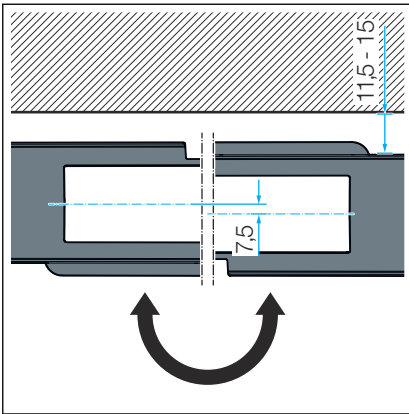

- The shower channel profile can be offset by 11.5–15 mm by rotating the top through 180°.

After alignment, fasten the height adjustment piece with tile adhesive.

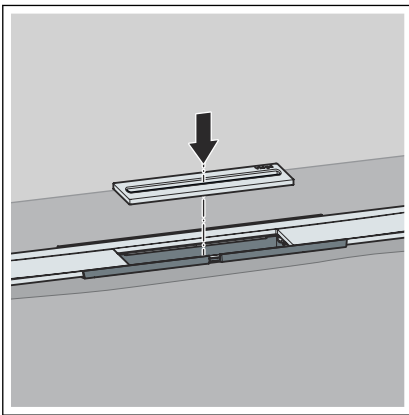

- Fit the shower channel inlay.

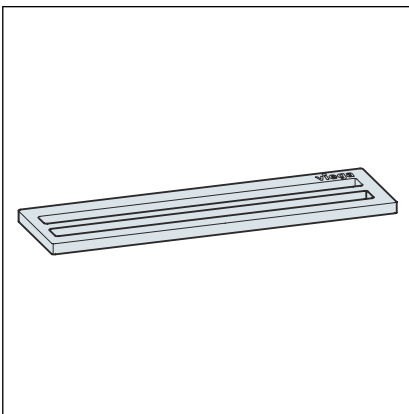

Two insert variants are available:

- Inlet opening double, model 4981.60

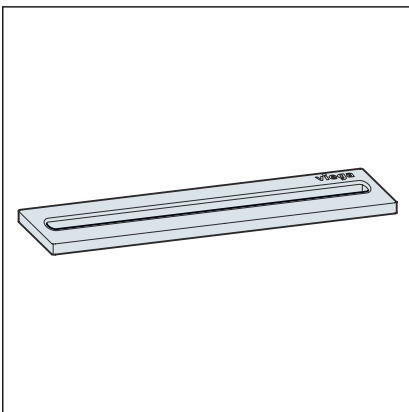

- Inlet opening single, model 4981.50

Laying the floor tiles

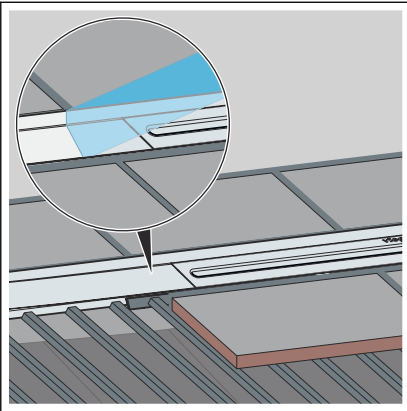

- Apply the tile adhesive.
- Lay the floor tiles up to the shower channel profile.
- Seal any gaps between tile and grate element with a suitable filler material or joint filler.
- Remove the protective foil.

3.3 Installation in self-levelling coating

3.3.1 Sealing the shower channel



- The seal set has to be handed over to the person responsible for the self-levelling coating (tiler).
- Only use the sealing accessories included in the scope of delivery.
- For wall mounting, work the sealing collar on the upright wall into the self-levelling coating or the bonded sealing.

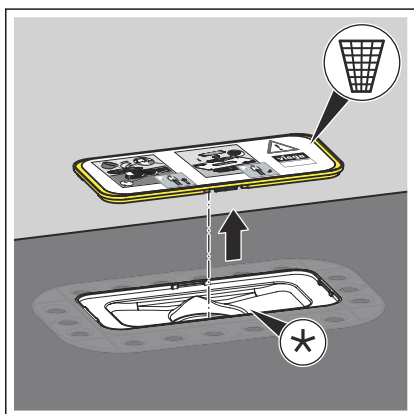

- Remove and dispose of the pre-mounted site protection. The flange must be clean and free from material residue.

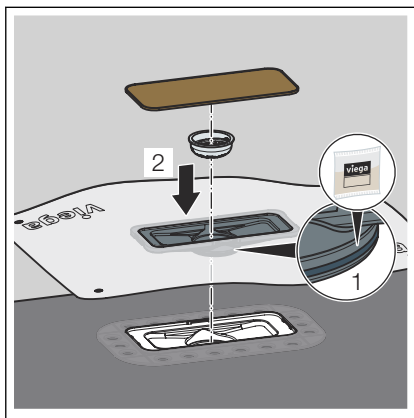

- Grease the sealing element.
- Clip the sealing collar into the flange.
- Check that the sealing element is properly positioned.
- Fit the sieve insert.
- Insert the wooden site protection.

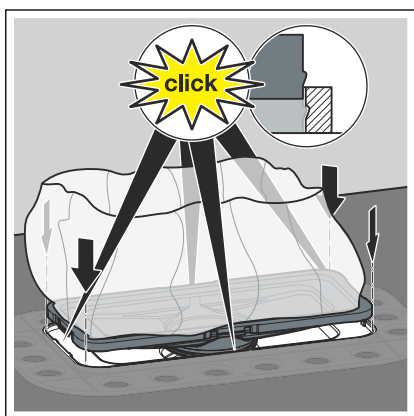

- Push the sealing collar into the flange as far as it will go. All four fixing points must engage.

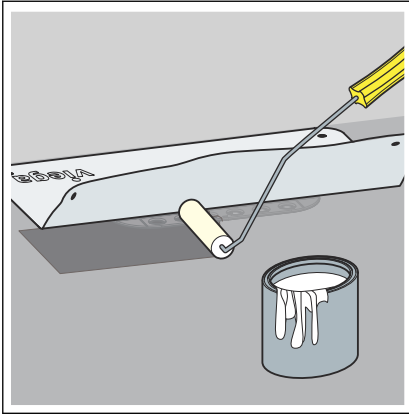

INFO! Observe the usage notes of the self-levelling coating manufacturer.

- Fold together the sealing collar.
- Prime the screed with the first layer of primer (e.g. with Arturo EP).
- Push the sealing collar in the still liquid primer without wrinkles.

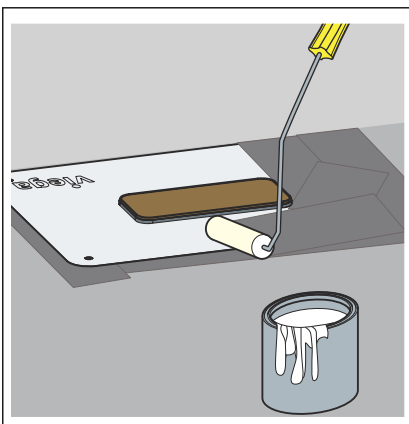

- Once the first layer has dried, apply the second layer of primer generously onto the sealing collar and screed.

3.3.2 Mounting height adjustment piece and shower channel profile

Determining dimensions



The shower channel profile can be shortened.

Coloured profiles can be likewise shortened. When the coloured profile (PVD-coated) is shortened, the stainless steel base material is visible at the cut edges. Mount the shortened profile so that the cut edge is not visible.

The shower channel profile is divided into two drain zones.

- 1 Drain zone (flat, no incline)
- 2 Drain zone (with contour, 1–2 % incline)

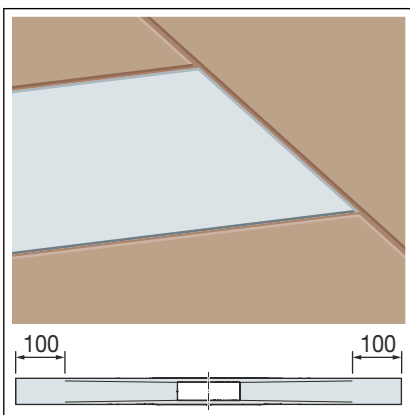
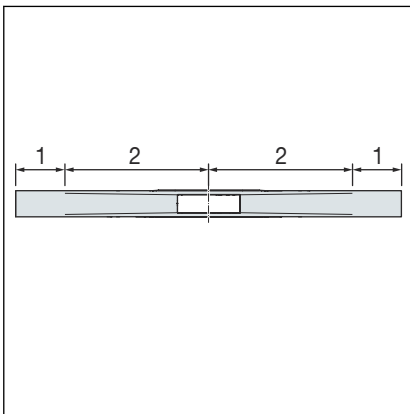

The shower channel profile can be shortened by up to 100 mm at the ends of the drain zone.

To be able to achieve individual profile lengths, the shower channel profile and the tiles are at the same height.

Shortening range of drain zone

Profile length	Shortening range
800 mm	600–800 mm
1000 mm	800–1000 mm
1200 mm	1000–1200 mm

* Offset between shower channel profile and tile

In the drain zone, the shower channel profile can be shortened to a minimum installation length of 150 mm from centre of the drain.

The resultant offset between the shower channel profile and the tile can be closed with a tile end rail or with silicon.

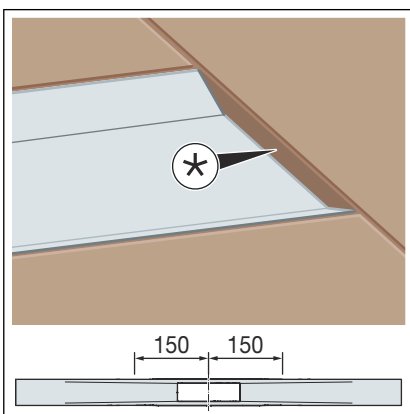

If channel solutions >1200 mm are required, the standard lengths of 800, 1000 and 1200 mm can be combined with one another.

To avoid an offset when laying several profiles, shorten the profiles only at the drain zone (max. 100 mm).

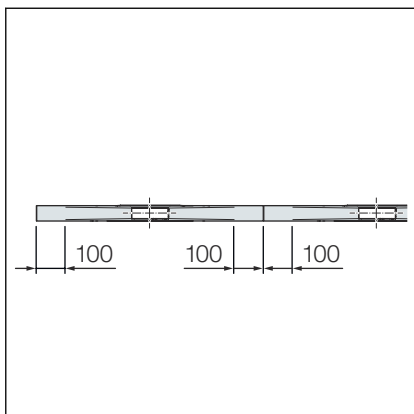

Shortening range of drain zone for extended shower channel profiles

Profile length	Shortening range
2 x 800 mm	1200–1600 mm
2 x 1000 mm	1600–2000 mm
2 x 1200 mm	2000–2400 mm

Shortening the shower channel profile

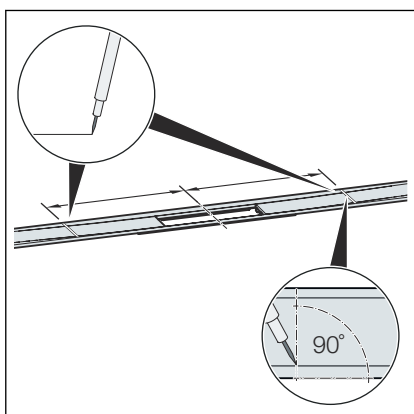

- Determine the required dimension and mark at right angles.

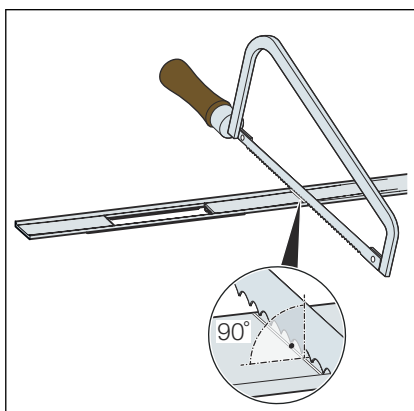

- Using a handsaw, shorten the shower channel profile at right angles and deburr.

Alternatively, the shower channel profile can be shortened using an electric metal slitting disc or a speed-restricted angle grinder with suitable stainless steel slitting disc.

NOTICE! To prevent corrosion, the tools must not have been used beforehand for processing ferrous materials.

Mounting the shower channel profile

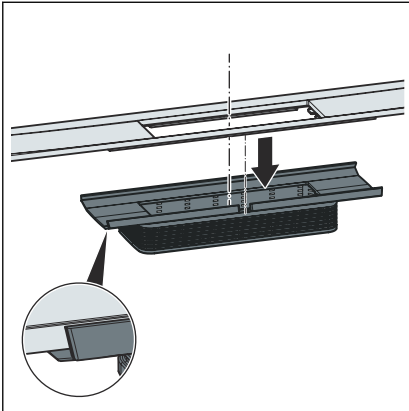

- Insert the shower channel profile into the height adjustment piece as far as it will go.

Make sure that shower channel profile protrusion sits exactly in the recess of the height adjustment piece.

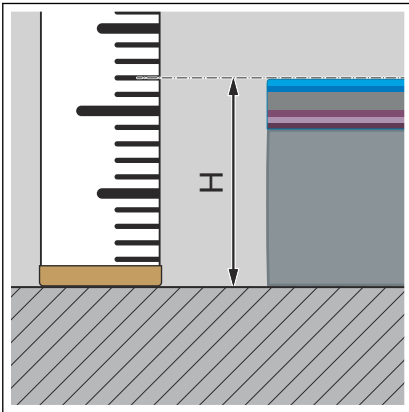

- Determine the flooring height H.

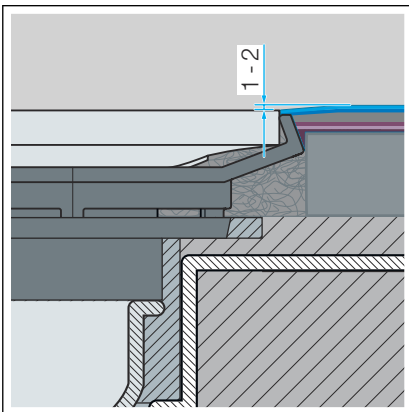

INFO! For fault-free drainage, Viega recommends laying the floor covering 1–2 mm higher than the shower channel profile.

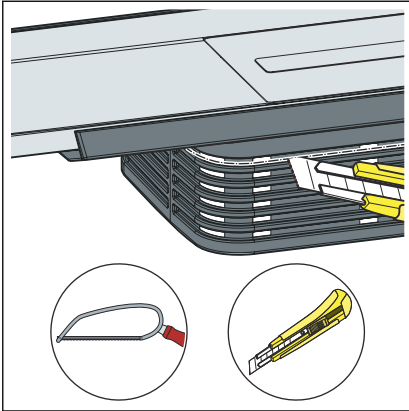

► Cut the height adjustment piece to the length of 12 mm and deburr.

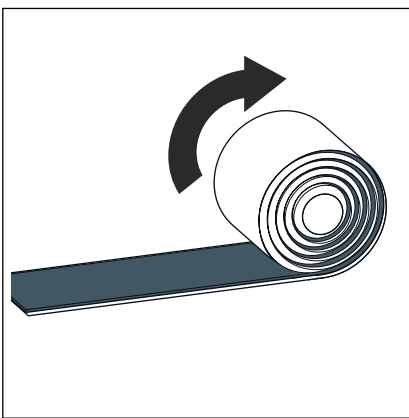

► Unroll the butyl tape and cut to size.

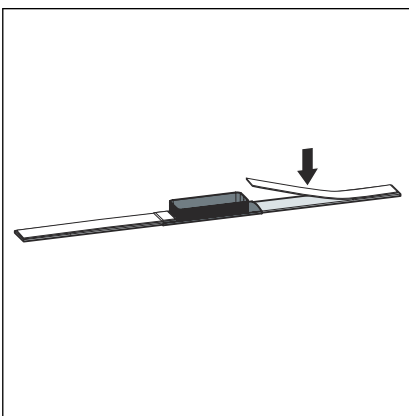

► Stick the butyl tape centrally on the underside of the shower channel profile.

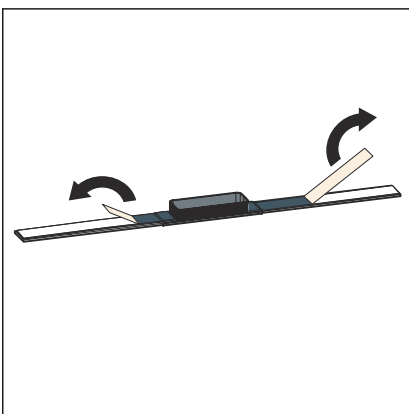

► Remove the protective foil.

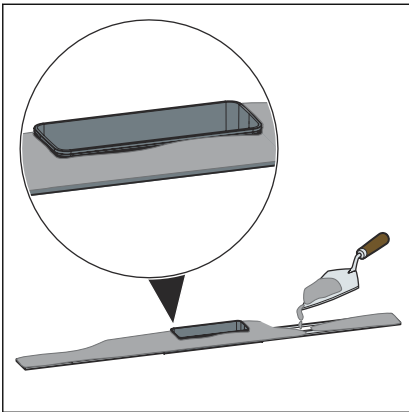

NOTICE! The flexural strength of the tile adhesive must conform to at least Class S1.

- Apply the tile adhesive over the entire underside of the shower channel profile and the height adjustment piece.

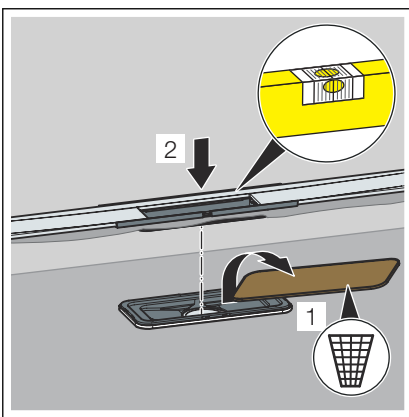

- Remove the wooden site protection.
- Insert the shower channel profile and the height adjustment piece.
- To prevent the scratch filler or self-levelling coating from running in, seal the area between height adjustment piece and drain with tile adhesive.
- Remove excess tile adhesive that has squeezed out at the sides of the profile.

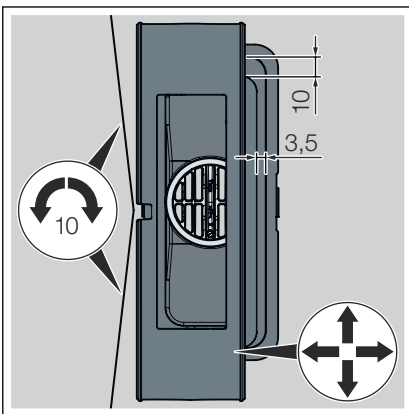

- Align the shower channel profile and the height adjustment piece horizontally.
 - The shower channel profile can be radially rotated by max. 10 mm (with a 1200 mm shower channel profile).
 - To adjust the shower profile to the tile pattern, the height adjustment piece can be moved on the long side by 3.5 mm and on the head side by 10 mm.

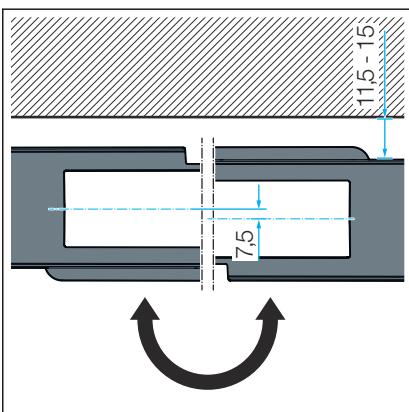

- The shower channel profile can be offset by 11.5–15 mm by rotating the top through 180°.

After alignment, fasten the height adjustment piece with tile adhesive.

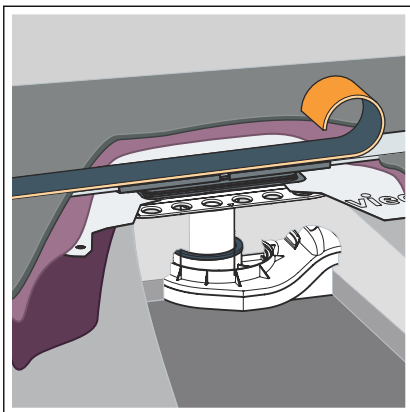

- To prevent the self-levelling coating being applied to the profile, mask the profile (e.g. with foam rubber tape or XPS foam sheet).
- Apply the scratch filler (e.g. Arturo EP) according to the manufacturer's instructions. Completely integrate the profile into the scratch filler.

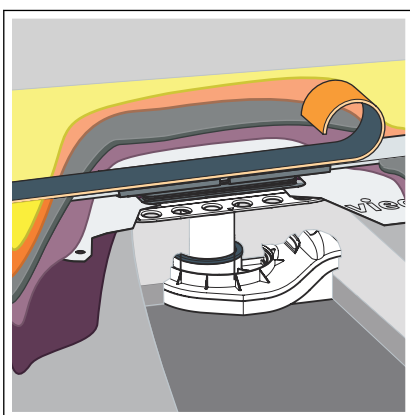

- When the scratch filler has dried, apply the self-levelling coating and sealant (e.g. Arturo PU) according to the manufacturer's instructions.

INFO! To prevent water accumulating on the shower channel profile, apply the self-levelling coating 1–2 mm higher than the profile.

- When the self-levelling coating has cured, remove the foam rubber tape or XPS foam sheet from the profile.
- Deburr the edge at the transition to the profile and clean.

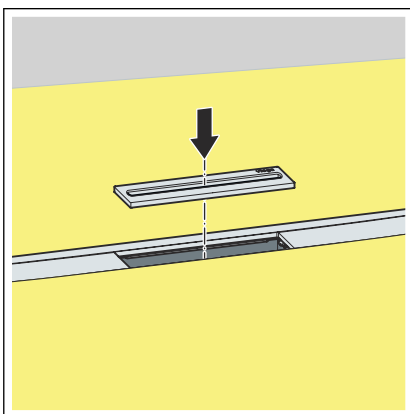

- Fit the shower channel inlay.

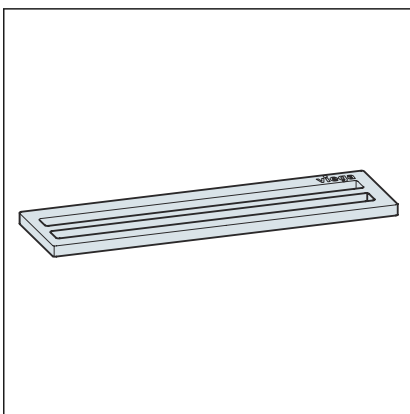

Two insert variants are available:

- Inlet opening double, model 4981.60

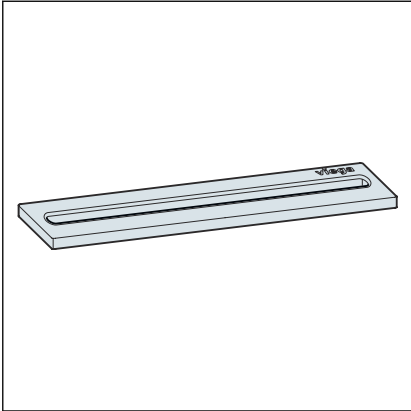

■ Inlet opening single, model 4981.50

4 Care

4.1 Care tips

Normal soap or a mild cleaning agent can be used for regular maintenance and prevention of lime scale on the grate and frame. Use no scouring agent or abrasive objects.

Strong stains, even around the drain unit and the odour trap, can be removed using typical household cleaner. Rinse the detergent very thoroughly with clear water after the prescribed dwell time. There should be no residue on the components.

5 Disposal

Separate the product and packaging materials (e. g. paper, metal, plastic or non-ferrous metals) and dispose of in accordance with valid national legal requirements.



Viega GmbH & Co. KG
service-technik@viega.de
viega.com

INT • 2022-08 • VPN200454

