

Instructions for Use

Easytop ball valve with SC-Contur



for drinking water and heating installation

Model
5370

Year built (from)
04/2010

viega

Table of contents

1	About these instructions for use	3
	1.1 Target groups	3
	1.2 Labelling of notes	3
	1.3 About this translated version	4
2	Product information	5
	2.1 Standards and regulations	5
	2.2 Intended use	7
	2.2.1 Areas of use	7
	2.2.2 Media	8
	2.3 Product description	8
	2.3.1 Overview	8
	2.3.2 Press connection with SC-Contur	9
	2.3.3 Markings on components	9
	2.3.4 Compatible components	9
	2.3.5 Technical data	10
	2.4 Information for use	10
	2.4.1 Corrosion	10
	2.5 Optional accessories	11
3	Handling	13
	3.1 Assembly information	13
	3.1.1 Mounting instructions	13
	3.1.2 Required tools	13
	3.2 Assembly	15
	3.2.1 Shortening the pipes	15
	3.2.2 Pressing the connection	16
	3.2.3 Pressing the connection	16
	3.2.4 Leakage test	17
	3.3 Maintenance	17
	3.4 Disposal	17

1 About these instructions for use

Trade mark rights exist for this document; for further information, go to viega.com/legal.

1.1 Target groups

The information in this manual is directed at heating and sanitary professionals and trained personnel.

Individuals without the abovementioned training or qualification are not permitted to mount, install and, if required, maintain this product. This restriction does not extend to possible operating instructions.

The installation of Viega products must take place in accordance with the general rules of engineering and the Viega instructions for use.

1.2 Labelling of notes

Warning and advisory texts are set aside from the remainder of the text and are labelled with the relevant pictographs.



DANGER!

This symbol warns of possible life-threatening injury.



WARNING!

This symbol warns of possible serious injury.



CAUTION!

This symbol warns of possible injury.



NOTICE!

This symbol warns of possible damage to property.



This symbol gives additional information and hints.

1.3 About this translated version

This instruction for use contains important information about the choice of product or system, assembly and commissioning as well as intended use and, if required, maintenance measures. The information about the products, their properties and application technology are based on the current standards in Europe (e. g. EN) and/or in Germany (e. g. DIN/DVGW).

Some passages in the text may refer to technical codes in Europe/Germany. These should serve as recommendations in the absence of corresponding national regulations. The relevant national laws, standards, regulations, directives and other technical provisions take priority over the German/European directives specified in this manual: The information herein is not binding for other countries and regions; as said above, they should be understood as a recommendation.

2 Product information

2.1 Standards and regulations

The following standards and regulations apply to Germany / Europe and are provided as a support feature.

Regulations from section: Fields of application

Scope / Notice	Regulations applicable in Germany
Planning, execution, operation and maintenance of potable water installations	DIN EN 806, part 1
Planning, execution, operation and maintenance of potable water installations	DIN EN 806, part 2
Planning, execution, operation and maintenance of potable water installations	DIN EN 806, part 3
Planning, execution, operation and maintenance of potable water installations	DIN EN 806, part 4
Planning, execution, operation and maintenance of potable water installations	DIN EN 806, part 5
Planning, execution, operation and maintenance of potable water installations	DIN EN 1717
Planning, execution, operation and maintenance of potable water installations	DIN 1988
Planning, execution, operation and maintenance of potable water installations	VDI/DVGW 6023
Planning, execution, operation and maintenance of potable water installations	Trinkwasserverordnung (TrinkwV)

Regulations from section: Media

Scope / Notice	Regulations applicable in Germany
Suitability for drinking water	Trinkwasserverordnung (TrinkwV)
Suitability for heating water for pump hot water heating systems	VDI 2035 Page 1 and page 2

Regulations from section: Product description

Scope / Notice	Regulations applicable in Germany
Suitability for drinking water installations	Trinkwasserverordnung (TrinkwV)
Suitability for drinking water installations	DIN 50930-6
Requirements in plastic components in drinking water installations	DVGW-Arbeitsblatt W270

Regulations from section: Overview

Scope / Notice	Regulations applicable in Germany
Compliance with the inspection requirements (fittings group I)	DIN EN 13828

Regulations from section: Marking on components

Scope / Notice	Regulations applicable in Germany
Designation noise class I	DIN EN 13828

Regulations from section: Corrosion

Scope / Notice	Regulations applicable in Germany
External corrosion protection	DIN EN 806-2
External corrosion protection	DIN 1988-200
External corrosion protection	DKI-Informationsdruck i. 160

Regulations from section: Leakage test

Scope / Notice	Regulations applicable in Germany
Leakage test for potable water installations	DIN EN 806, part 4
Leakage test for potable water installations	ZVSHK-Merkblatt „Dichtheitsprüfungen von Trinkwasserinstallationen mit Druckluft, Inertgas oder Wasser“

Regulations from section: Maintenance

Scope / Notice	Regulations applicable in Germany
Operation and maintenance of potable water installations	DIN EN 806-5

2.2 Intended use



Coordinate the use of the model for areas of use and media other than those described with the Viega Service Center.

2.2.1 Areas of use

Use is possible in the following areas among others:

- Raxofix PE-Xc/Al/PE-Xc pipes (dimensionally stable, with external oxygen seal coat)
 - Drinking water installations
 - Industrial and heating systems
 - Compressed air systems
- Raxofix PE-Xc pipes (flexible without external oxygen seal coat)
 - Drinking water installations

The general rules of engineering and the applicable regulations must be observed for planning, execution, operation and maintenance potable water installations, see ↗ *'Regulations from section: Fields of application'* on page 5.

2.2.2 Media

The model is also suitable for the following media, amongst others:

- Drinking water without limitations acc. to the applicable directives, see ↗ *'Regulations from section: Media' on page 6*
- maximum chloride concentration 250 mg/l pursuant to applicable regulations, see ↗ *'Regulations from section: Media' on page 6*
- Heating water for pump hot water heating systems, see ↗ *'Regulations from section: Media' on page 6*
- Rainwater
- Compressed air in compliance with the specification of the sealing elements being used
 - EPDM at oil concentration < 25 mg/m³

2.3 Product description

According to the applicable regulations, Easytop system fittings can be used for all types of potable water and are DVGW certified, see ↗ *'Regulations from section: Product description' on page 6*. Their plastic components comply with the KTW recommendation and the requirements pursuant to the applicable regulations.

2.3.1 Overview



The Easytop system fittings comply with the test requirements specified in the applicable regulations, see ↗ *'Regulations from section: Overview' on page 6*.
Sound protection $L_{ap} \leq 20 \text{ dB(A)}$

The model is equipped as follows:

- valve casing made of gunmetal/silicon bronze
- dual-sided Raxofix press connection with SC-Contur
- actuating lever made of plastic
- protective caps for the actuating lever in the red and green for the identification of the corresponding area of use
- position indication open/closed
- key surface on the casing
- maintenance-free selector shaft
- ball seal made of Teflon®

The model is available in the following dimensions: d 16 / 20 / 25 / 32 / 40 / 50 / 63

2.3.2 Press connection with SC-Contur

SC-Contur



Fig. 1: SC-Contur

Viega press connections are equipped with the SC-Contur. The SC-Contur is a safety technology that is certified by the DVGW and ensures that the connection is guaranteed to be leaky in an unpressed state. In this way, unpressed connections are noticed immediately during a leakage test.

Viega guarantees that unpressed connections are visible during a leakage test:

- with wet leakage test in the pressure range from 0.1 hPa–0.65 MPa (1.0 mbar–6.5 bar)
- with dry leakage test in the pressure range from 22 hPa–0.3 MPa (22 mbar–3.0 bar)

2.3.3 Markings on components

The press connections are marked with a coloured dot. This identifies the SC-Contur, where the test medium would escape in the case of an inadvertently unpressed connection.

The model is marked as follows:

- noise class I pursuant to applicable regulations, see [☞ 'Regulations from section: Marking on components' on page 6](#)
- dimension
- DVGW writing
- green dot for potable water
- Position indicator on the actuating lever

2.3.4 Compatible components

The model is equipped with Raxofix press connections and compatible with the Raxofix system.

Pipes

Raxofix plastic pipes are available as coiled bundle with and without protective pipe, and with various insulation thicknesses. Dimensionally stable multilayer pipes are also available in 5 m lengths. The following pipes are available:

- **Raxofix PE-Xc/Al/Pe-Xc**
 - dimensionally stable
 - with external oxygen seal coat
 - d 16, 20, 25, 32, 40, 50, 63
- **Raxofix PE-Xc**
 - flexible
 - without external oxygen seal coat
 - d 16, 20

2.3.5 Technical data

Observe the following operating conditions for the installation of the model:

Operating temperature [T_{max}]	70 °C
Operating pressure [P_{max}]	1.0 MPa (10 bar)

2.4 Information for use

2.4.1 Corrosion

Overground pipelines and fittings in rooms do not normally require external corrosion protection.

There are exceptions in the following cases:

- Contact with aggressive building materials such as nitrite or materials containing ammonium
- Contact with aggressive chemicals
- in aggressive surroundings

If external corrosion protection is required, observe the pertinent guidelines, see [🔗 'Regulations from section: Corrosion' on page 6](#).



Easytop fittings made of gunmetal/silicon bronze are suitable for all types of potable water.

The chloride concentration in the medium must not exceed a maximum value of 250 mg/l.

This chloride is not a disinfectant, but in fact pertains to the content in sea and table salt (sodium chloride).

2.5 Optional accessories

The following optional accessories are available:

- actuating lever made of metal
- actuating lever made of plastic
- Protective caps for the actuating lever made of plastic in red and green for the identification of the corresponding area of use
- Insulating shells



Fig. 2: Model 2270.21 Easytop actuating lever made of plastic



Fig. 3: Model 2270.26 Easytop actuating lever made of metal



Fig. 4: Model 2270.23, protective cap in blue

Insulating shells

EPS insulating shells are available for all sizes of ball valves. The two-piece shells are self-supporting and are mounted without tools and holding grips. They connect seamlessly to the front surfaces of the pipeline insulation.



Fig. 5: Model 2210.40 Easytop insulating shell

3 Handling

3.1 Assembly information

3.1.1 Mounting instructions

Checking system components



Do not remove the model from the packaging until immediately before use.

System components may, in some cases, become damaged through transportation and storage.

- Check all parts.
- Replace damaged components.
- Do not repair damaged components.
- Contaminated components may not be installed.

During assembly

Observe the following when mounting:

- Use suitable tools.
- Installation is not dependent on the direction of flow.



Choose the place of installation so that the fitting is easily accessible, simple to operate and the insulating shell can be well mounted.

Laying and fixing pipes

Information can be found in the Raxofix system instructions for use.

Length expansion

Information can be found in the Raxofix system instructions for use.

3.1.2 Required tools

The following tools are required for production of a press connection:



Hand or electric saws or angle grinders are not permitted.

- press machine with constant pressing force
- suitable Raxofix press jaw for PE-Xc systems
- pipe shear (model 5341) for dimensions 16–25 mm
- pipe cutters (model 2191) for dimensions 32–63 mm
- bending tool (model 5331 or 5331.2)



Fig. 6: Raxofix, press jaws

Recommended Viega press machines:

- Pressgun 5
- Pressgun Picco
- Pressgun 4E / 4B
- Picco
- Type PT3-AH
- Type PT3-H / EH
- Type 2 (PT2)

3.2 Assembly

3.2.1 Shortening the pipes



NOTICE! **Leaky press connections due to damaged material!**

Press connections can become leaky due to damaged pipes.

For information about tools, also see [Chapter 3.1.2 'Required tools'](#) on page 13.

Dimensions 16–25 mm

- Cut the protective pipe to length using the protective pipe cutter (model 5341).

- Cut the pipe to length using a pipe shear.
Make sure that the cut surface is clean and straight.

Dimensions 32–63 mm

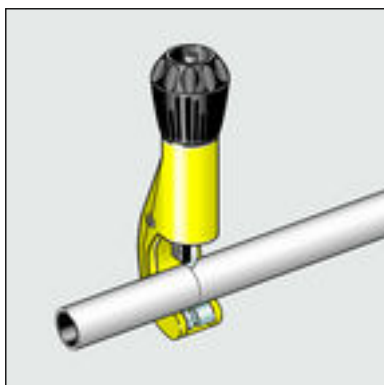

- Cut the pipe to length using a pipe cutter (model 2191).

3.2.2 Pressing the connection



You will find information regarding the intervals in the Raxofix system instructions for use.

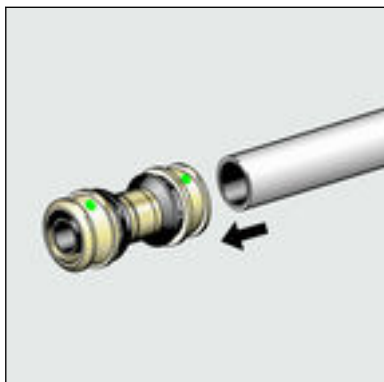

- Push the pipe into the press connector until the pipe end is visible in the inspection window.

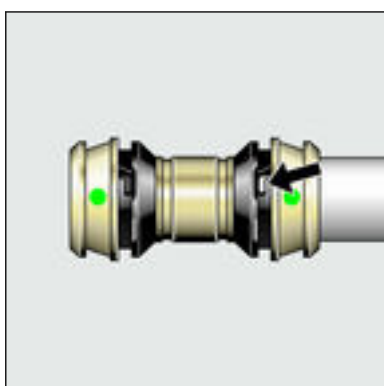

- Check the insertion depth in the inspection window.

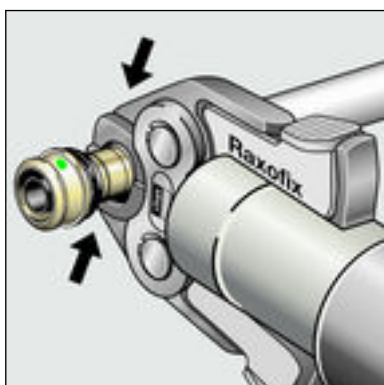

- Open the press jaw and place at a right-angle onto the connector. Carry out the pressing process.
- ☐ Connection is pressed.

3.2.3 Pressing the connection

Requirements:

- The pipe end is not bent or damaged.
- The pipe is deburred.
- The correct sealing element is in the press connector.

3.2.4 Leakage test

The installer must perform a leakage test before commissioning.

Carry out this test on a system that is finished but not yet covered.

Comply with the general rules of engineering and the applicable directives, see ↗ *'Regulations from section: Leakage test' on page 7.*

Perform leakage test should in acc. with the general rules of engineering for non-potable water installations.

Document the result.

3.3 Maintenance



NOTICE!

Inform your customer or the operator of the drinking water installation that the system has to be maintained on a regular basis.

Observe the applicable regulations for the operation and maintenance of drinking water installations, see ↗ *'Regulations from section: Maintenance' on page 7.*



Viega recommends actuating the fitting regularly and checking its function.

3.4 Disposal

Separate the product and packaging materials (e. g. paper, metal, plastic or non-ferrous metals) and dispose of in accordance with valid national legal requirements.



Viega GmbH & Co. KG
service-technik@viega.de
viega.com

INT • 2022-08 • VPN180121

