

# Instructions for Use

## Advantix stacking element

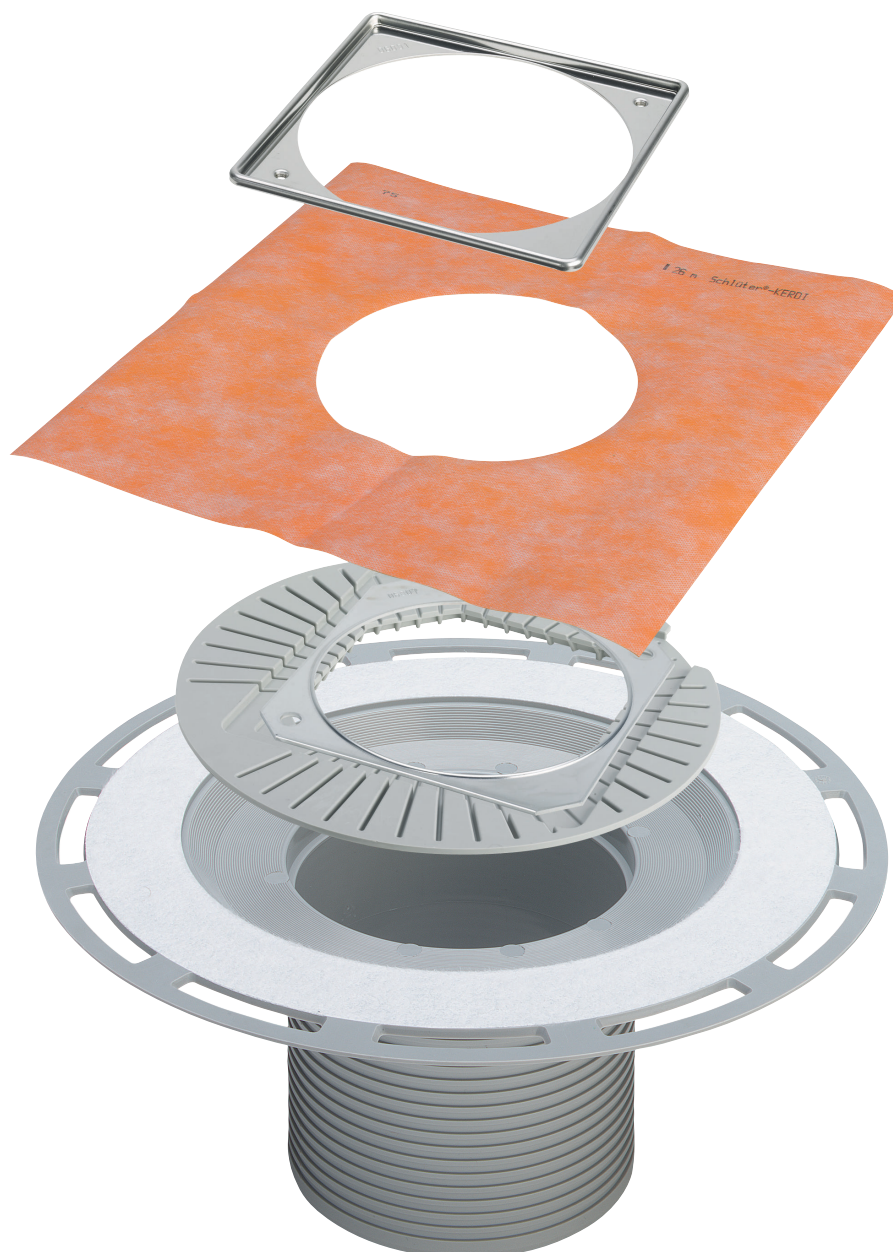

for bonded sealing (tiled shower) with sealing mat

**Model**  
4994.1

**Year built (from)**  
01/2008

**viega**

# Table of contents

<b>1</b>	<b>About these instructions for use</b>	<b>3</b>
	1.1 Target groups	3
	1.2 Labelling of notes	3
	1.3 About this translated version	4
<b>2</b>	<b>Product information</b>	<b>5</b>
	2.1 Standards and regulations	5
	2.2 Intended use	5
	2.2.1 Areas of use	5
	2.2.2 Media	6
	2.3 Product description	6
	2.3.1 Overview	6
	2.4 Information for use	6
	2.4.1 Sealing	6
	2.5 Required accessories	8
<b>3</b>	<b>Handling</b>	<b>9</b>
	3.1 Assembly information	9
	3.1.1 Important note	9
	3.1.2 Installation dimensions	9
	3.1.3 Tools and materials	9
	3.2 Assembly	10
	3.2.1 Mounting stacking element	10
	3.2.2 Sealing the drain	11
	3.2.3 Mounting eccentric adjuster	13
	3.3 Disposal	16

# 1 About these instructions for use

Trade mark rights exist for this document, further information can be found at [viega.com/legal](http://viega.com/legal).

## 1.1 Target groups

The information in this instruction manual is directed at the following groups of people:

- Heating and sanitary professionals and trained personnel
- Tilers

It is not permitted for individuals without the abovementioned training or qualification to mount, install and, if required, maintain this product. This restriction does not extend to possible operating instructions.

The installation of Viega products must take place in accordance with the general rules of engineering and the Viega instructions for use.

## 1.2 Labelling of notes

Warning and advisory texts are set aside from the remainder of the text and are labelled with the relevant pictographs.



### **DANGER!**

This symbol warns against possible life-threatening injury.



### **WARNING!**

This symbol warns against possible serious injury.



### **CAUTION!**

This symbol warns against possible injury.



### **NOTICE!**

This symbol warns against possible damage to property.



Notes give you additional helpful tips.

### 1.3 About this translated version

This instruction for use contains important information about the choice of product or system, assembly and commissioning as well as intended use and, if required, maintenance measures. The information about the products, their properties and application technology are based on the current standards in Europe (e. g. EN) and/or in Germany (e. g. DIN/DVGW).

Some passages in the text may refer to technical codes in Europe/Germany. These should serve as recommendations in the absence of corresponding national regulations. The relevant national laws, standards, regulations, directives and other technical provisions take priority over the German/European directives specified in this manual: The information herein is not binding for other countries and regions; as said above, they should be understood as a recommendation.

## 2 Product information

### 2.1 Standards and regulations

The following standards and regulations apply to Germany / Europe. National regulations can be found on the relevant web site of your country at [viega.com/standards](http://viega.com/standards).

#### Regulations from section: Sealing

Scope / Notice	Regulations applicable in Germany
Stress class of the underground, as well as suitable bonded sealing	ZDB-Merkblatt 8/2012
Stress class of the underground, as well as suitable bonded sealing	Leitfaden zur Abdichtung im Verbund (AIV)
Approved bonded sealings with proof of practicability in keeping with building law for stress classes A and AO	ETAG 022 T1
Approved bonded sealings with proof of practicability in keeping with building law for stress classes A, B and C	DIBt-Bauregelliste A, Teil 2 des DIBt und Prüfgrundsätze für Abdichtungen im Verbund (PG AIV-F)
Permitted bonded sealings	EN 14891

#### Regulations from section: Media

Scope / Notice	Regulations applicable in Germany
Typical domestic wastewater	DIN 1986-3

### 2.2 Intended use

#### 2.2.1 Areas of use

The stacking element is intended for height increase and bonded sealing of an Advantix drain above cement layers.

## 2.2.2 Media

The drain and stacking element are intended for draining of household-type wastewater in constant operation, see ↗ *'Regulations from section: Media' on page 5.*

- The short-term temperature of the wastewater may reach up to 95° C. The temperature must be considerably lower in constant operation.
- The pH value must be higher than 4 but lower than 10.

It is not permitted to introduce wastewater which would damage the product material.

## 2.3 Product description

### 2.3.1 Overview

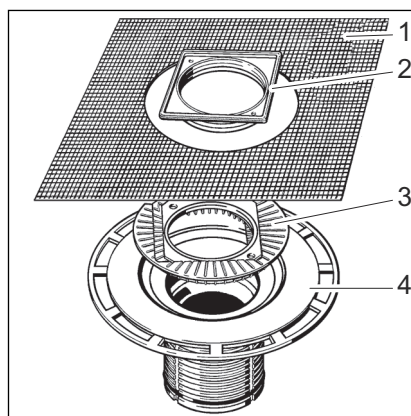

- 1 - sealing collar
- 2 - stainless steel frame with spacer rings
- 3 - eccentric adjuster
- 4 - sealing collar
- 5 - Stacking element with flange for the application of the bonded sealing

## 2.4 Information for use

### 2.4.1 Sealing

#### Bonded sealing

To protect against moisture penetration, apply sealing foils, which are to be processed in liquid state, directly below the tiles on screed and walls. The determination of the stress class and the underground as well as the selection of the suitable bonded sealing must be carried out in compliance with the valid standards and regulations, see: ↗ *'Regulations from section: Sealing' on page 5.*

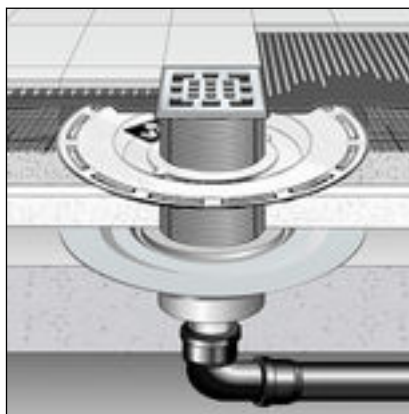

Fig. 1: Diagram of a bonded seal with stacking element

### Important note

Careful planning is required for professional sealing. In addition, depending on the individual dampness wear class and the type of foundation, a suitable BS system with a building regulations certificate of suitability must be chosen.

Furthermore, the following factors should be taken into account:

- Drain or shower channel must be equipped with a special flange, which has an adhesive surface and a width of at least 30 mm.
- For bridging the material change from drain to screed, either a suitable sealing collar or sealing tape designed for overlapping with the BS over a width of at least 50 mm must be used.
- The screed must be laid at a minimum incline of 1–2 %.
- The installation must be carried out properly in acc. with the mounting instructions and the manufacturer's information.

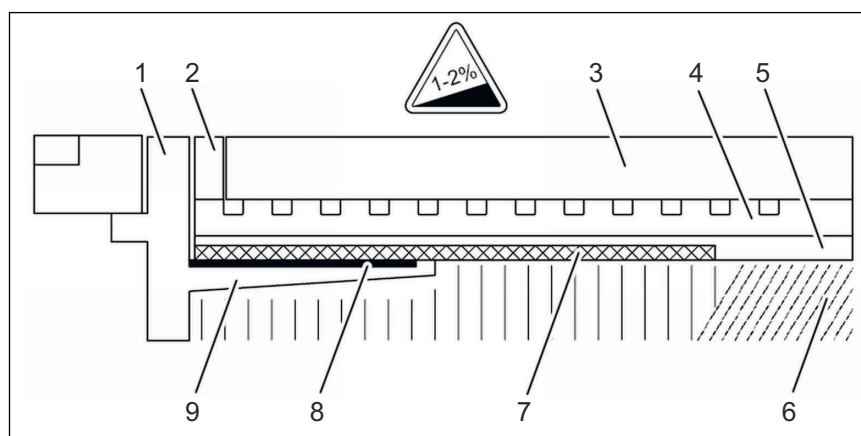

Fig. 2: Construction diagram of the bonded seal - min. screed incline 1–2 %

- 1 - Grate
- 2 - Top piece with adhesive flange
- 3 - Tile
- 4 - Tile cement
- 5 - Bonded sealing
- 6 - Screed
- 7 - Sealing collar
- 8 - Mat
- 9 - Adhesive flange

### Permitted bonded seals

In connection with suitable drains, only approved bonded sealings with proof of practicability in keeping with building law may be used. See ↗ *'Regulations from section: Sealing'* on page 5.

Information regarding the procedure can be found in the instructions for use of the corresponding product.

## 2.5 Required accessories

### Grate

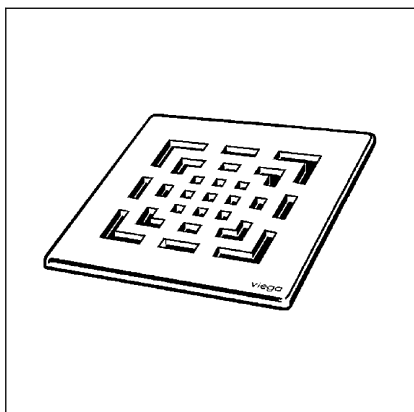

A grate must be purchased separately to complete the mounting of the drain. Advantix grates are available in a number of sizes and variations (see catalogue).



## 3 Handling

### 3.1 Assembly information

#### 3.1.1 Important note

Before assembly:

- Check if the installation height of the drain and stacking element corresponds with the planned floor construction.
- Ensure that the drain has been fully lined with mortar.
- If necessary, supply the required accessories ↗ *Chapter 2.5 'Required accessories' on page 8.*

During assembly:

- Observe installation dimensions.

After assembly:

- The flange must be fully lined with mortar.

#### 3.1.2 Installation dimensions

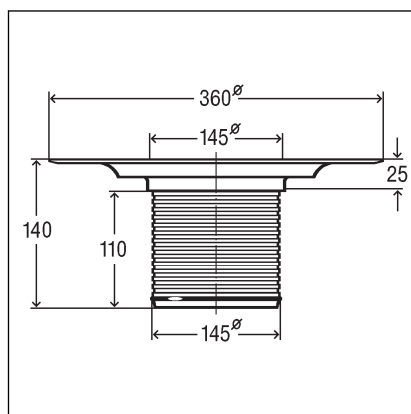

Fig. 3: Dimensional drawing for model 4994.1

#### 3.1.3 Tools and materials

##### Required material

- Advantix grate

## 3.2 Assembly

### 3.2.1 Mounting stacking element

#### Requirements

- The drain has been mounted and lined in accordance with the instructions for use.
- Remove yellow protective plug from the drain.

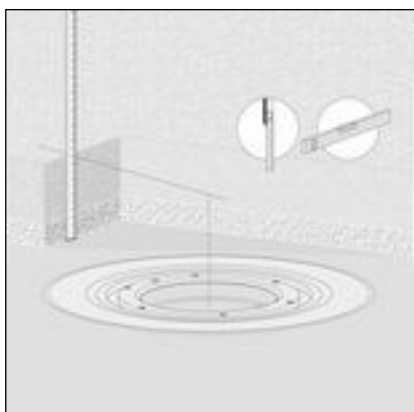

- Calculate the height of the floor construction from the edge in the inside of the drain up to the upper edge of the floor.

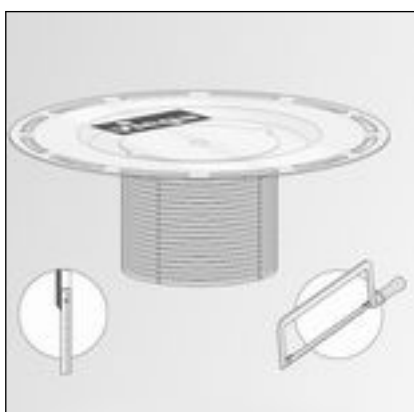

- Starting with the upper edge, transfer the measured height onto the stacking element.
- Cut the stacking element to the marked height.

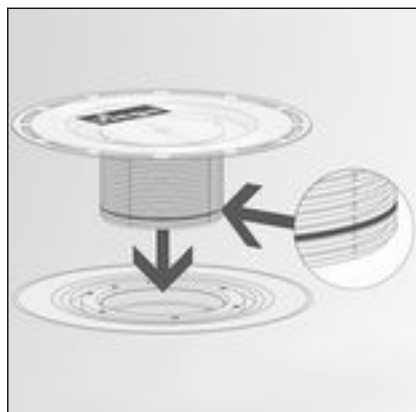

- Install backflow seal.
- Insert stacking element in drain.

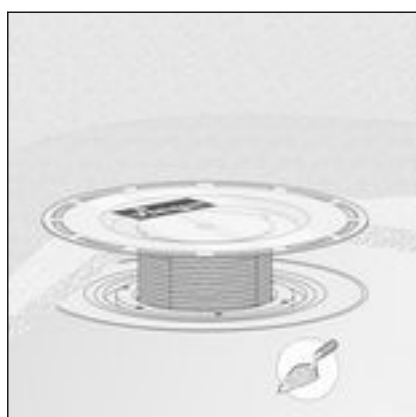

- Work the stacking element into the screed or floor covering.



**NOTICE!**  
**Product damage due to improper installation**

If hollow spaces occur during the lining of the stacking element, leaks may occur when pressure is applied.

Inform the subsequent workers that the flange of the stacking element must be fully lined and that there must be no hollow spaces.

### 3.2.2 Sealing the drain



**NOTICE!**  
**Product damage due to improper installation**

If hollow spaces occur during the lining of the flange, leaks may occur when pressure is applied.

Check the proper completion of the subsequent work.



Screed and floor tiles must be laid at an incline of 1–2 % in the direction of the drain.

## Bonded sealing

### Requirements:

- The flange is free of heavy soil.
- The complete surface of the flange is lined with material and undamaged.
- Remove protective foil.

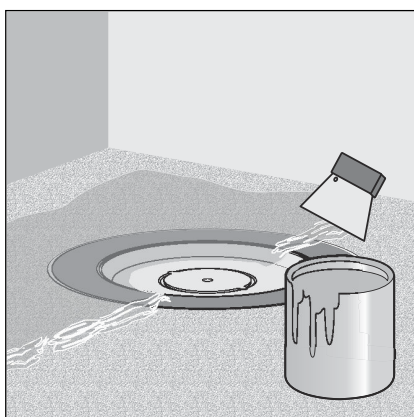
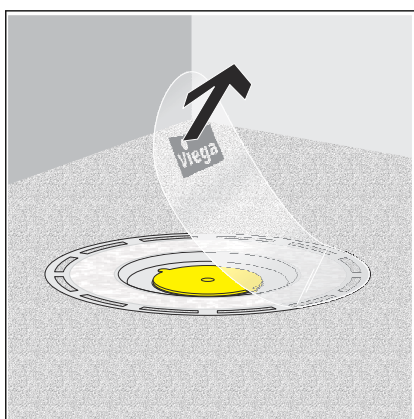

- Apply the bonded sealing on the dry screed and spread to the inner edge of the flange fleece.

**NOTICE!** Observe the bonded sealing manufacturer's instructions for use.

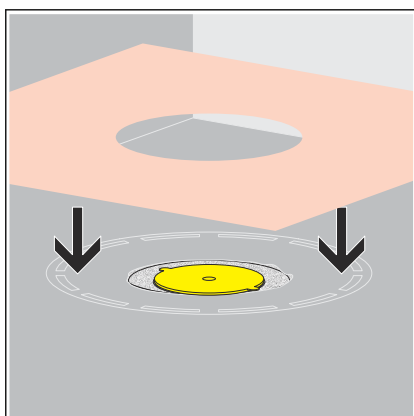

- Lay the sealing collar into the bonded sealing.

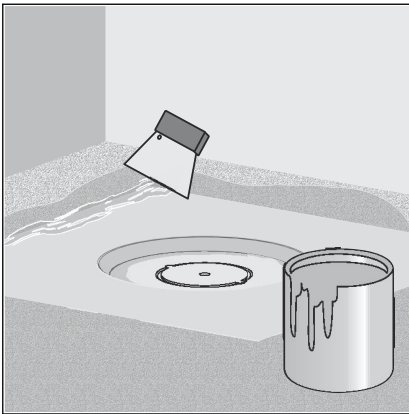

- Apply a second layer of bonded sealing onto the sealing collar and, if necessary, onto the floor.

### 3.2.3 Mounting eccentric adjuster

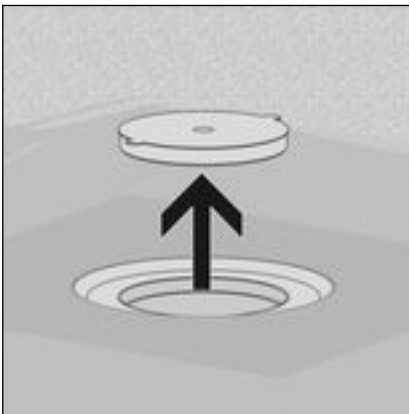

- Remove yellow protective plug.

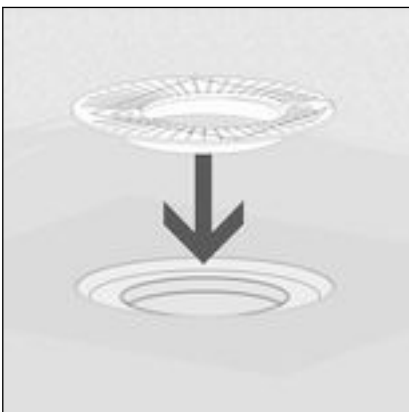

- Insert eccentric adjuster.

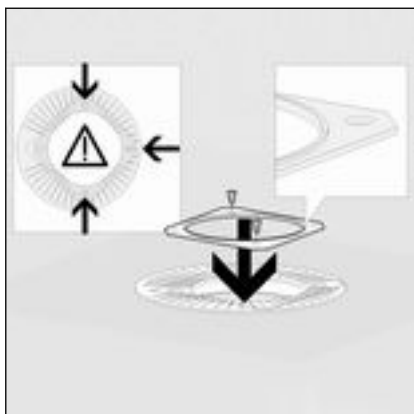

- Insert distance ring seat with the internal edge facing upwards.
- Screw spacer ring seat together.



- Calculate the height of the floor construction from the edge in the inside of the stacking element up to the upper edge of the tiles.

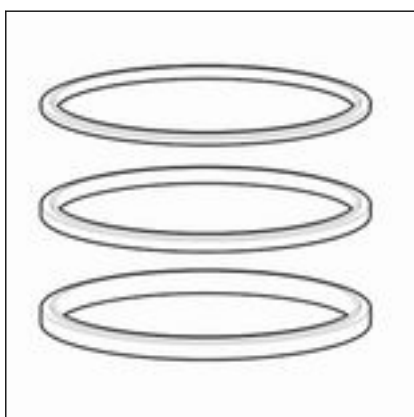

- Select spacer rings.

Height up to upper edge of tiles [mm]	spacer rings to be inserted
4.5	only spacer ring seat
7.5	3 (beige)
9.5	5 (white)
11.5	7 (yellow)
12.5	3 + 5
14.5	3 + 7
16.5	5 + 7
19.5	3 + 5 + 7

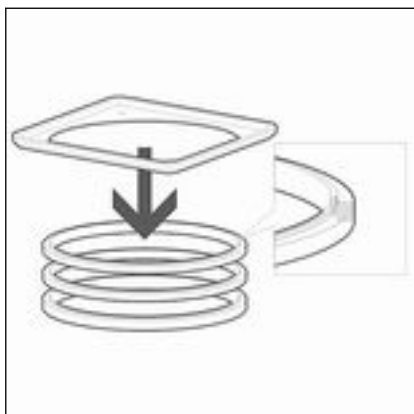

**NOTICE!** If spacer rings are used, the stainless steel frame must be placed in the tile adhesive to maintain the strength and stability.

- ▶ Plug stainless steel frame and spacer rings together.  
The raised side faces upwards and the hollow side downwards.

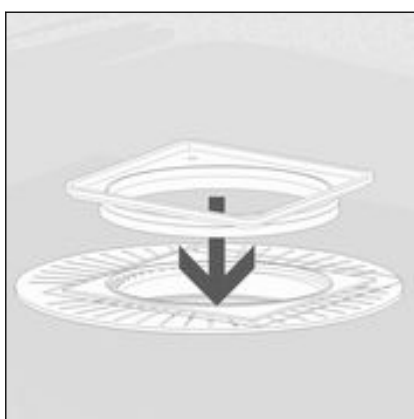

- ▶ Place the stainless steel frame and the spacer ring(s) into the eccentric insert (adjusting range up to 15 mm to each side).

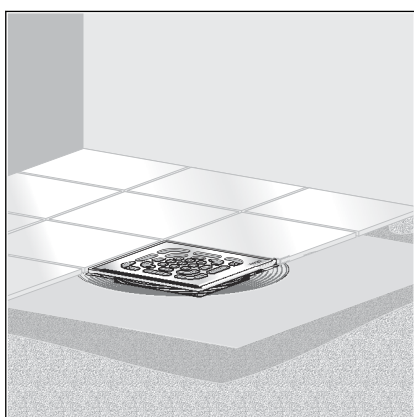

- ▶ Insert grate.
- ▶ Lay tiles.

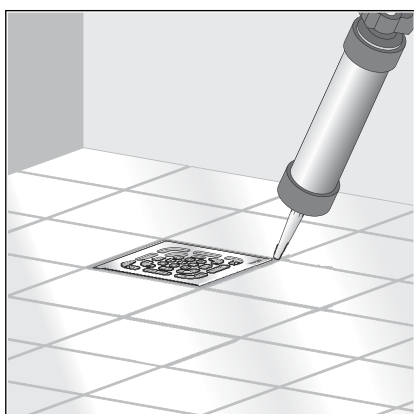

- ▶ Close gap between stainless steel frame and tiles with silicone.

### 3.3 Disposal

Separate the product and packaging materials (e. g. paper, metal, plastic or non-ferrous metals) and dispose of in accordance with valid national legal requirements.





**Viega GmbH & Co. KG**  
service-technik@viega.de  
viega.com

INT • 2022-08 • VPN170316

