

Instructions for Use

Geopress

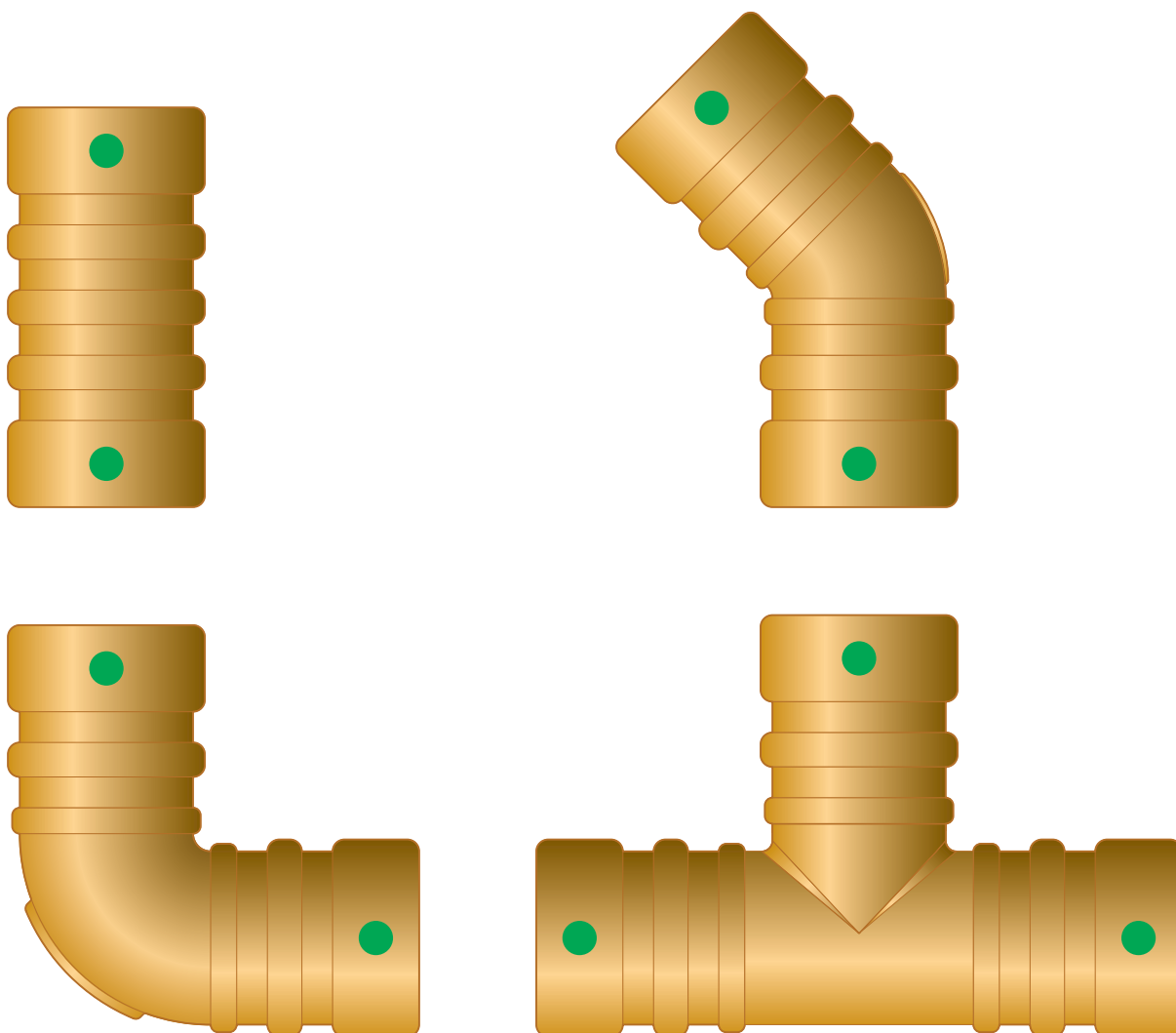

Press connector system made of gunmetal for underground PE-HD and PE-X pipes

System
Geopress

viega

Table of contents

1	About these instructions for use	3
	1.1 Target groups	3
	1.2 Labelling of notes	3
	1.3 About this translated version	4
2	Product information	5
	2.1 Standards and regulations	5
	2.2 Intended use	7
	2.2.1 Areas of application	7
	2.2.2 Media	7
	2.3 Product description	8
	2.3.1 Overview	8
	2.3.2 Pipes	9
	2.3.3 Press connectors	10
	2.3.4 Sealing elements	10
	2.3.5 Markings on components	11
	2.4 Information for use	12
	2.4.1 Corrosion	12
3	Handling	13
	3.1 Transport	13
	3.2 Storage	13
	3.3 Assembly information	13
	3.3.1 Mounting instructions	13
	3.3.2 Permitted exchange of sealing elements	14
	3.3.3 Space requirements and intervals	14
	3.3.4 Required tools	16
	3.4 Assembly	17
	3.4.1 Replacing the sealing element	17
	3.4.2 Shortening the pipes	17
	3.4.3 Deburring the pipes	18
	3.4.4 Pressing the connection	18
	3.4.5 Leakage test	21
	3.5 Disposal	21

1 About these instructions for use

Trade mark rights exist for this document; for further information, go to viega.com/legal.

1.1 Target groups

The information in this manual is directed at utility and pipeline construction companies and their technical professionals.

Only specialist companies which can prove they are qualified in accordance with the applicable directives may be engaged for the construction of potable water house service connections, see ↪ *'Regulations from section: Target group'* on page 5.

The applicable regulations must be observed for potable water house service connections, see ↪ *'Regulations from section: Target group'* on page 5.

The installation of Viega products must take place in accordance with the general rules of engineering and the Viega instructions for use.

1.2 Labelling of notes

Warning and advisory texts are set aside from the remainder of the text and are labelled with the relevant pictographs.



DANGER!

This symbol warns of possible life-threatening injury.



WARNING!

This symbol warns of possible serious injury.



CAUTION!

This symbol warns of possible injury.



NOTICE!

This symbol warns of possible damage to property.



This symbol gives additional information and hints.

1.3 About this translated version

This instruction for use contains important information about the choice of product or system, assembly and commissioning as well as intended use and, if required, maintenance measures. The information about the products, their properties and application technology are based on the current standards in Europe (e.g. EN) and/or in Germany (e.g. DIN/DVGW).

Some passages in the text may refer to technical codes in Europe/Germany. These should serve as recommendations in the absence of corresponding national regulations. The relevant national laws, standards, regulations, directives and other technical provisions take priority over the German/European directives specified in this manual: The information herein is not binding for other countries and regions; as said above, they should be understood as a recommendation.

2 Product information

2.1 Standards and regulations

The following standards and regulations apply to Germany / Europe and are provided as a support feature.

Regulations from section: Target group

Scope / Notice	Regulations applicable in Germany
Qualification of specialist companies	DVGW-Arbeitsblatt GW 301
Qualification and requirements in the potable water supplier	DVGW-Arbeitsblatt W 1000

Regulations from section: Application areas

Scope / Notice	Regulations applicable in Germany
Planning, execution, operation and maintenance of potable water house service connections	DIN EN 805
Planning, execution, operation and maintenance of potable water house service connections	DVGW-Arbeitsblatt W 400-1
Planning, execution, operation and maintenance of potable water house service connections	DVGW-Arbeitsblatt W 400-2
Planning, execution, operation and maintenance of potable water house service connections	DVGW-Arbeitsblatt W 400-3
Use in geothermal energy systems	VDI 4640
Application in local heat supply systems	Arbeitsgemeinschaft Fernwärme

Regulations from section: Media

Scope / Notice	Regulations applicable in Germany
Suitability for potable water	Trinkwasserverordnung (TrinkwV)

Regulations from section: Pipes

Scope / Notice	Regulations applicable in Germany
Permitted types of pipes (PE) – potable water supply	DIN EN 12201
Permitted use with piping materials in potable water installations (PE-HD)	DIN 8074/75
Permitted types of pipes (PE) – potable water supply	DVGW-Arbeitsblatt GW 335-A2
Permitted types of pipes (PE-X) – potable water supply	DIN 16892/16893
Types of pipes (PE-X) – potable water supply	DVGW-Arbeitsblatt GW 335-A3

Regulations from section: Corrosion

Scope / Notice	Regulations applicable in Germany
(Subsequent) corrosion protection for underground installation	DIN 30672

Regulations from section: Transport

Scope / Notice	Regulations applicable in Germany
Transport	Einbauhinweise A 1465 - Pressure pipelines

Regulations from section: Storage

Scope / Notice	Regulations applicable in Germany
Requirements for material storage	DIN EN 806-4, Chapter 4.2
Requirements for material storage	Einbauhinweise KRV A 1465 - Pressure pipelines

Regulations from section: Notes on mounting

Scope / Notice	Regulations applicable in Germany
Threshold values for ovalities	DIN 12201-2, Table 1

Regulations from section: Leakage test

Scope / Notice	Regulations applicable in Germany
Leakage test before commissioning the connection line	DVGW-Arbeitsblatt W 400-2
Leakage test before commissioning the connection line	DIN EN 805

2.2 Intended use



Agree the use of the system for areas of application and media other than those described with Viega.

The Viega Geopress system can be applied at outdoor temperatures from -10 °C to 60 °C. The component temperatures of the press connectors and the press machine must not be less than -5 °C.

2.2.1 Areas of application

The system is intended for use in potable water, local heat supply systems and the supply of geothermal energy.

Potable water installation

For planning, execution and operation of potable water house service connections, observe the applicable regulations, see ↗ *'Regulations from section: Application areas'* on page 5.

Local heat supply systems

Local heat supply systems must be executed in compliance with the applicable regulations, see ↗ *'Regulations from section: Application areas'* on page 5.

Geothermal energy systems

Geothermal energy systems must be executed in compliance with the applicable regulations, see ↗ *'Regulations from section: Application areas'* on page 5.

2.2.2 Media

The system is suitable for the following media, see ↗ *'Regulations from section: Media'* on page 5:

- Potable water

The max. operating pressure and the max. operating temperature depend on the type of pipe used and the specific application.

Potable water

- Operating temperature $T_{\max} = 25\text{ °C}$
- Operating pressure $p_{\max} = 1.6\text{ MPa (16 bar)}$

Local heat supply systems

- Operating temperature $T_{\max} = 95\text{ °C}$
- Operating pressure $p_{\max} = 0.6\text{ MPa (6 bar)}$

Use of the support sleeve made of gunmetal/silicon bronze (model 9605) required

Geothermal energy

- In the temperature range from $T_{\min} = -15\text{ °C}$ up to $T_{\max} = 70\text{ °C}$ with operating pressure $p_{\max} = 0.6\text{ MPa (6 bar)}$
Only in connection with support sleeve model 9605 made of gunmetal.
- In the temperature range from $T_{\min} = -15\text{ °C}$ up to $T_{\max} = 50\text{ °C}$ with operating pressure $p_{\max} = 1.6\text{ MPa (16 bar)}$

When using PE-X pipes, always use the support sleeve model 9605 made of gunmetal.

2.3 Product description

2.3.1 Overview

The piping system consists of press connectors for underground PE-HD and PE-X pipes and the corresponding press tools.

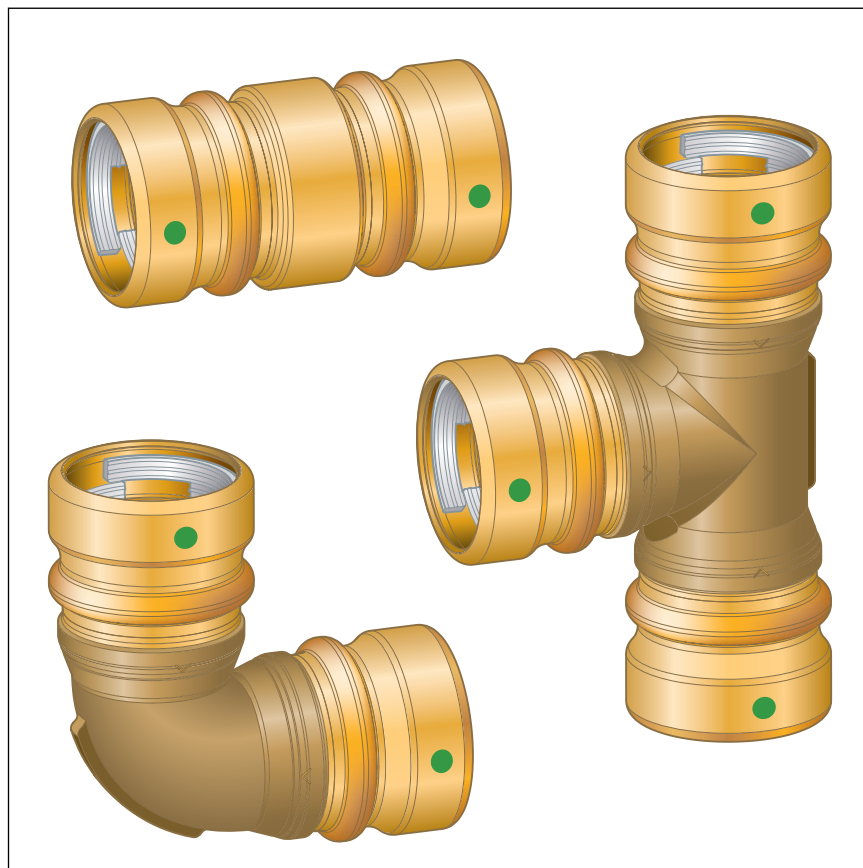

Fig. 1: Geopress press connectors

The system components are available in the following dimensions:
d 25 / 32 / 40 / 50 / 63.

2.3.2 Pipes

Only the following plastic pipes may be used for installations with Geopress components:

Permitted types of pipes – potable water supply

Type of pipe ¹⁾	SDR	PFA
PE 80	9.0	1.6 MPa (16 bar)
PE 80	11.0	1.26 MPa (12.5 bar)
PE 100	11.0	1.6 MPa (16 bar)
PE-X ²⁾	11.0	1.25 MPa (12.5 bar)

¹⁾ see ↪ 'Regulations from section: Pipes' on page 6

²⁾ Only in combination with support sleeve model 9605 made of gun-metal.

2.3.3 Press connectors

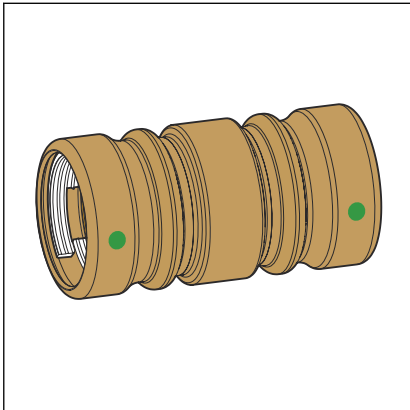

Fig. 2: Press connectors

The press connectors have a circumferential bead in which the sealing element lies. The press connector is deformed upstream and downstream of the bead and permanently connected to the pipe during pressing. Geopress press connectors are equipped with a clamping ring made of POM for a longitudinal force resistant connection.

SC-Contur

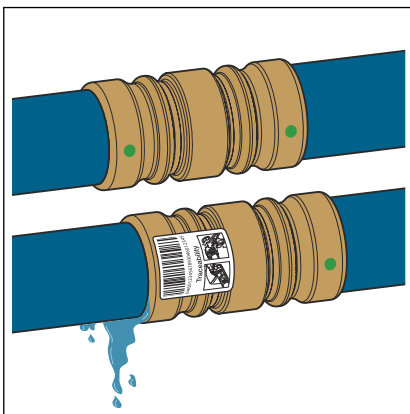

Fig. 3: SC-Contur

Viega press connectors are equipped with the SC-Contur. The SC-Contur is a safety technology that is certified by the DVGW and ensures that the press connector is guaranteed to be leaky in an unpressed state. In this way, inadvertently unpressed connections are noticed during a leakage test.

Viega guarantees that accidentally unpressed connections become visible during a leakage test:

- with the wet leakage test in the pressure range from 0.1–0.65 MPa (1.0–6.5 bar)
- with dry leakage test in the pressure range from 22 hPa–0.3 MPa (22 mbar–3.0 bar)

2.3.4 Sealing elements

The press connectors are factory-fitted with EPDM sealing elements.

Area of use of the EPDM sealing element

Area of application	Potable water	Compressed air	Geothermal energy I ¹⁾	Geothermal energy II	Local heating ¹⁾
Operating temperature [T _{max.}]	25 °C	—	70 °C	50 °C	95 °C
Operating temperature [T _{min.}]	—	—	-15 °C	-15 °C	—

¹⁾ Only in combination with support sleeve model 9605 made of gunmetal.

Area of application	Potable water	Compressed air	Geothermal energy I ¹⁾	Geothermal energy II	Local heating ¹⁾
Operating pressure [P _{max}]	1.6 MPa (16 bar)	1.0 MPa (10 bar)	0.6 MPa (6 bar)	1.6 MPa (16 bar)	0.6 MPa (6 bar)
Comments	—	dry, oil content < 25 mg / m ³	maximum 50 % glycol level in total water content	maximum 50 % glycol level in total water content	—

¹⁾ Only in combination with support sleeve model 9605 made of gunmetal.

2.3.5 Markings on components

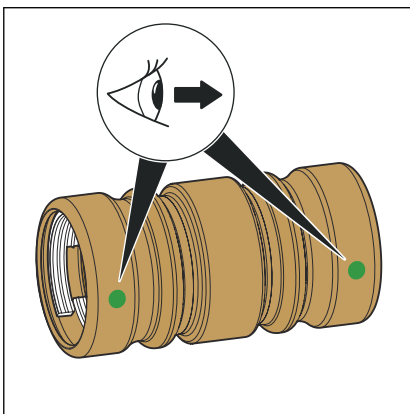

Fig. 4: Marking

The green dot shows that the press connector is equipped with the SC-Contur and that the system is suitable for potable water.

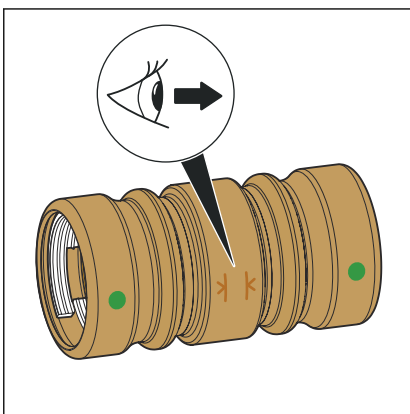

Fig. 5: Marking of the insertion depth

Geopress press connectors are marked with an indicator to determine the insertion depth.



The position of newly laid pipes and connection lines, including detailed information about pipeline parts, must be documented and regularly updated. The traceability code on the press connector allows every press connector to be traced back and simplifies the documentation in as-completed drawings. The sticker with the traceability code is removed after pressing and shows the pressing has taken place.

2.4 Information for use

2.4.1 Corrosion

Due to a lower probability of corrosion in the case of laying in the ground and in contact with ground and surface waters with pH-values between 6 and 8, corrosion protection is not required. Soils containing ammoniac require corrosion protection in acc. with the pertinent guidelines, see ↗ *'Regulations from section: Corrosion' on page 6.*

Only components and supplies (e. g. sealant) that have been awarded a DVGW test symbol may be used.

3 Handling

3.1 Transport



Do not remove the press connector from the packaging until immediately before use.

For transport, comply with the requirements specified in the applicable regulations, see ↗ *'Regulations from section: Transport' on page 6*

3.2 Storage



Do not remove the press connector from the packaging until immediately before use.

For storage, comply with the requirements specified in the applicable regulations, see ↗ *'Regulations from section: Storage' on page 6:*

- Place protective caps on pipes with large diameters and thin walls to guard against deformation.
- Avoid strong sunlight and heating.
- In addition, observe the instructions provided by the pipe manufacturer.

3.3 Assembly information

3.3.1 Mounting instructions

Checking system components

System components may, in some cases, have become damaged through transportation and storage.

- Check all parts.
- Replace damaged components.
- Do not repair damaged components.

Inspect pipes visually for the following damage before installation:

- Ovalities: threshold values must not be exceeded, see ↗ *'Regulations from section: Notes on mounting' on page 6.*
- Dents
- Cracks

- Grooves
- damaged pipe ends

Only process the sections of the pipes, which do not exhibit these features.

3.3.2 Permitted exchange of sealing elements



Important instruction

With their material-specific qualities, sealing elements in press connectors are adapted for use with the corresponding media and/or the areas of use of the piping systems and are generally only certified for them.

The exchange of a sealing element is generally permitted. The sealing element must be exchanged for a designated spare part for the intended application ↪ *Chapter 2.3.4 'Sealing elements' on page 10*. The use of other sealing elements is not permitted.

Exchanging a sealing element is permitted in the following situations:

- if the sealing element in the press connector is obviously damaged and should be exchanged for a Viega spare sealing element made of the same material

3.3.3 Space requirements and intervals

Pressing between pipelines

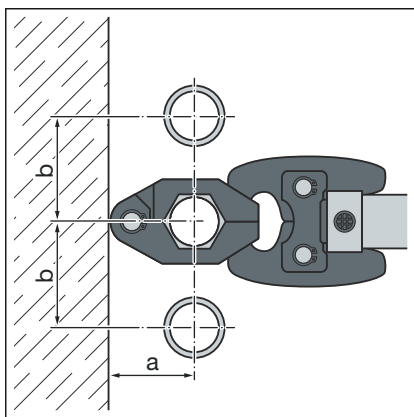

d	25	32	40	50	63
a [mm]	60	65	75	85	95
b [mm]	60	60	70	75	85

Pressing between pipe and wall

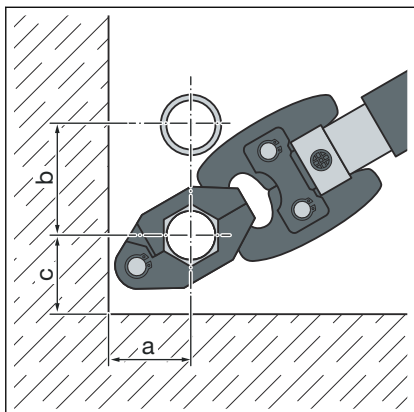

d	25	32	40	50	63
a [mm]	60	65	70	80	90
b [mm]	80	100	120	125	135
c [mm]	40	40	45	50	55

Wall distance

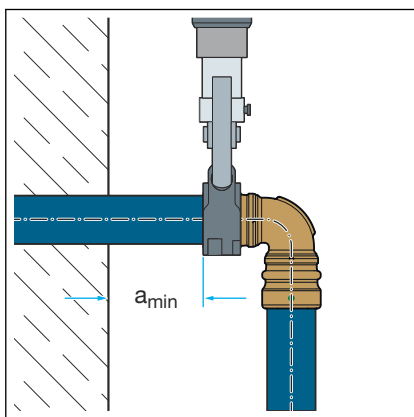

Minimum distance with d 25–63

Press machine	a_{min} [mm]
Pressgun 4B	50
Pressgun 5	
Pressgun 6 / 6 Plus	

Interval between the pressings



NOTICE!
Leaking press connections due to pipes being too short!

If two press connectors are to be mounted onto a pipe without an interval, the pipe must not be too short. If the pipe is not inserted up to the prescribed insertion depth in the press connector during pressing, the connection may become leaky.

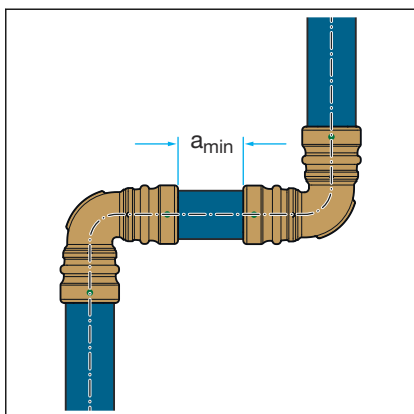

Minimum distance with press rings d25–63

d	a_{min} [mm]
25	20
32	22
40	20
50	20
63	20

Pipe trenches

Minimum distances to underground pipelines and objects:

- 0.2 m to parallel supply pipelines
- 0.1 m to crossing pipelines
Alternatively, use insulating materials, to prevent pipelines that cross each other from touching.
- 0.4 m to parallel electric cables over 1 kV
- 0.4 m to foundation or similar constructions
- In the case of a distance < 1 m, the potable water pipeline must not be lower than the wastewater pipe.

Z dimensions

For the Z dimensions, refer to the respective product page in the online catalogue.

3.3.4 Required tools

The following tools are required for production of a press connection:

- pipe cutter, pipe shear or saw
- deburrer and coloured pen for marking
- Battery-powered press machine
- hinged adapter jaw model 2296.2
 - Z1 with 25 mm diameter
 - Z2 with 32–63 mm diameter
- Press ring model 9696.1

Follow the care instructions for the pressing machine, see *Care instructions*.



Viega recommends the use of Viega system tools when installing the press fittings.

The Viega system press tools have been developed and tailored specifically for the installation of Viega press connector systems.

For information on how to combine Viega press machines with systems and accessories, please visit *Viega Tool Assistant*.

3.4 Assembly

3.4.1 Replacing the sealing element

Removing the sealing element



Do not use pointed or sharp-edged objects to remove the sealing element. They may damage the sealing element or the bead.

- Remove the sealing element from the bead.
- Remove the sealing element from the bead, leaving the clamping ring in the press connector. Proceed carefully to avoid damaging the clamping ring.

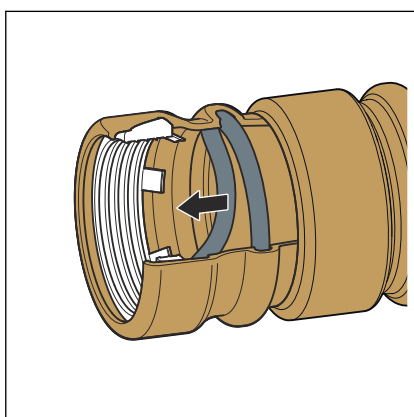

Inserting the sealing element

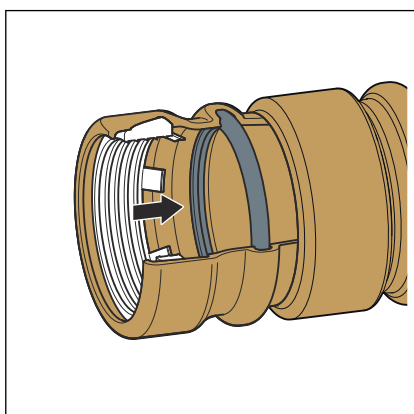

- Insert a new, undamaged sealing element into the bead below the clamping ring.
Make sure that the sealing element is not damaged by the clamping ring.
- Ensure that the complete sealing element is in the bead.

3.4.2 Shortening the pipes

For information about tools, also see ↗ [Chapter 3.3.4 'Required tools'](#) on page 16.

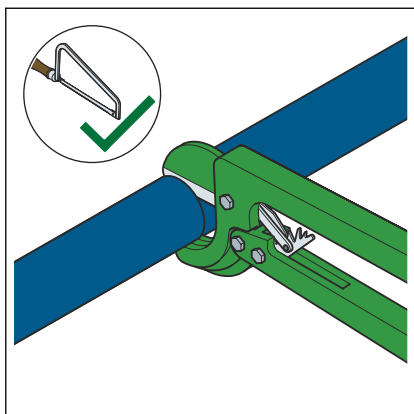

- Cut the pipe to length at right-angles using a pipe shear, pipe cutter or saw.

3.4.3 Deburring the pipes

The pipe ends must be thoroughly deburred internally and externally if shortened using a saw.

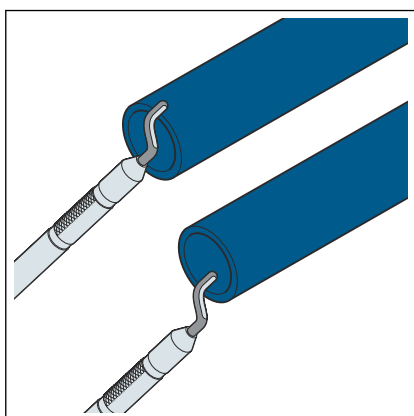

- Deburr the inside and outside of the pipe.

3.4.4 Pressing the connection

Requirements:

- The pipe end is not bent or damaged.
- The pipe is deburred.
- The sealing element and clamping ring are undamaged.
- Use the support sleeve model 9605 only when using PE-X pipes.

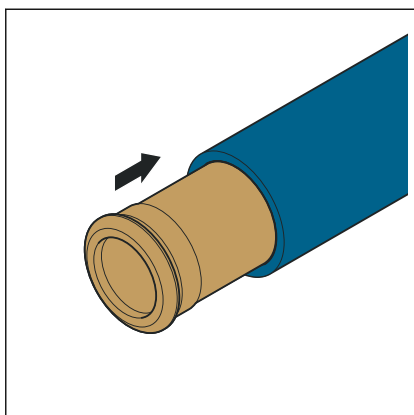

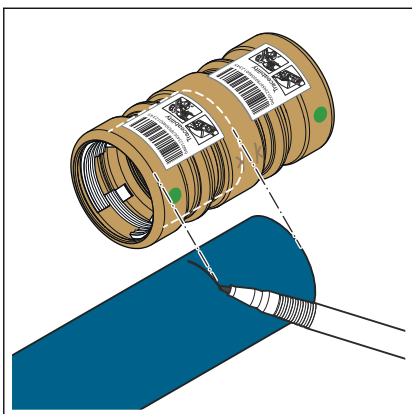

- Mark the insertion depth with the help of the marking on the press connector.

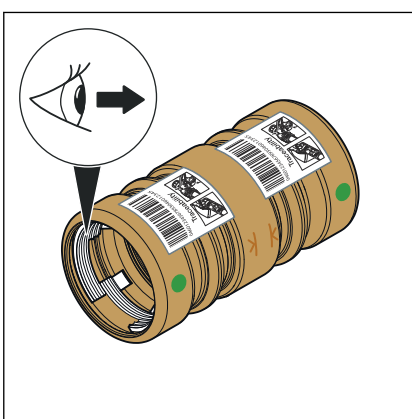

- Ensure that the sealing element is properly positioned.

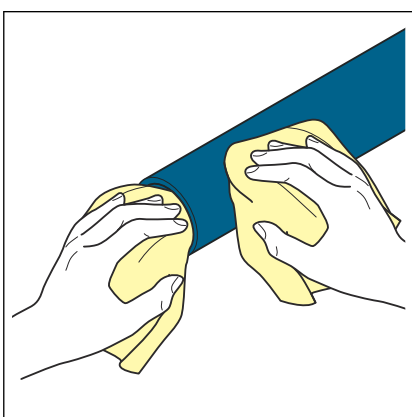

- Clean the pipe surface with a damp cloth.

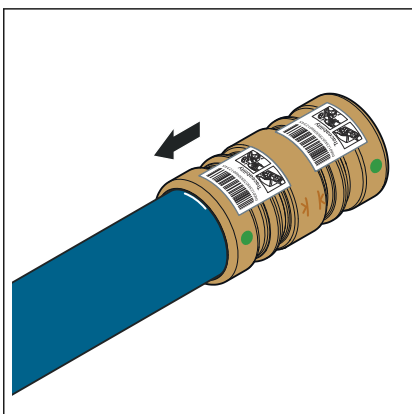

- Push the press connector up to the marked insertion depth on the pipe.
- Avoid contamination of the sealing element.

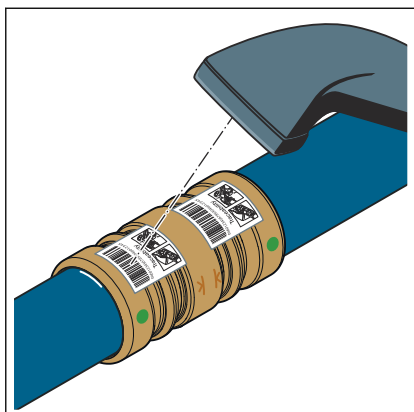

- Scan in the traceability code.

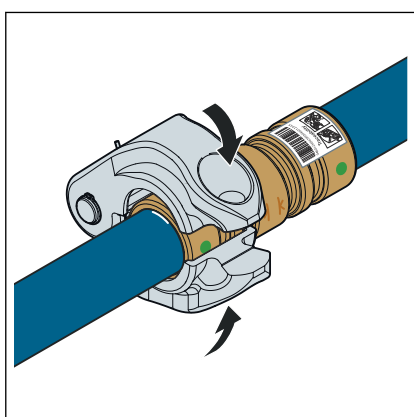

- Open the press ring and place it onto the press connector.

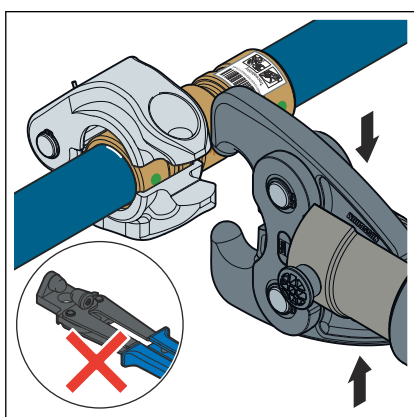

- Open the hinged adapter jaw and latch it into the holding fixture of the press ring.

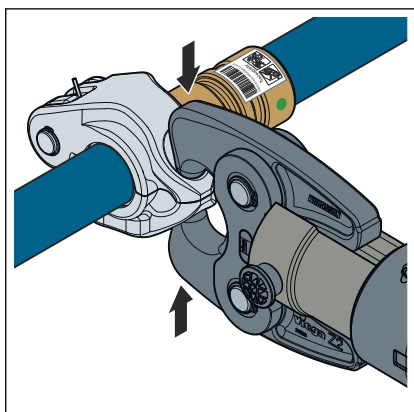

- Check the insertion depth.
- Carry out the pressing.

NOTICE!

The press ring must close completely during pressing.

- Make sure there is adequate space at the pressing point.
- Keep the press jaw contour and the area around the pressing point clean.

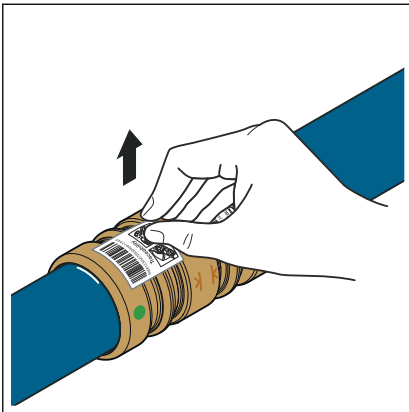

➤ Remove the traceability code.

◻ The connection is marked as having been pressed.

3.4.5 Leakage test

Perform a leakage test according to the applicable regulations before commissioning the connection line, see [🔗 'Regulations from section: Leakage test' on page 7.](#)

Carry out the test on a house service connection that is finished but not yet covered. The result of the leakage test must be documented as proof of the safety of the pipeline.

3.5 Disposal

Separate the product and packaging materials (e. g. paper, metal, plastic or non-ferrous metals) and dispose of in accordance with valid national legal requirements.



Viega GmbH & Co. KG
service-technik@viega.de
viega.com

INT • 2022-08 • VPN200487

