

Instructions for Use

Advantix rainwater drain



for pipeline connections from DN 50–100

Model
4970

Year built (from)
01/2008

viega

Table of contents

1	About these instructions for use	3
	1.1 Target groups	3
	1.2 Labelling of notes	3
	1.3 About this translated version	4
2	Product information	5
	2.1 Standards and regulations	5
	2.2 Intended use	5
	2.2.1 Areas of use	5
	2.2.2 Media	5
	2.2.3 Drainage capacity	5
	2.3 Product description	6
	2.3.1 Overview	6
	2.3.2 Technical data	7
	2.4 Information for use	7
	2.4.1 Installation variations	7
3	Handling	8
	3.1 Assembly information	8
	3.1.1 Important note	8
	3.1.2 Installation dimensions	8
	3.2 Assembly	9
	3.2.1 Connecting the drain	9
	3.3 Care	10
	3.3.1 Care tips	10
	3.4 Disposal	10

1 About these instructions for use

Trade mark rights exist for this document; for further information, go to viega.com/legal.

1.1 Target groups

The information in this instruction manual is directed at the following groups of people:

- Heating and sanitary professionals and trained personnel
- Consumers

Individuals without the abovementioned training or qualification are not permitted to mount, install and, if required, maintain this product. This restriction does not extend to possible operating instructions.

The installation of Viega products must take place in accordance with the general rules of engineering and the Viega instructions for use.

1.2 Labelling of notes

Warning and advisory texts are set aside from the remainder of the text and are labelled with the relevant pictographs.



DANGER!

This symbol warns of possible life-threatening injury.



WARNING!

This symbol warns of possible serious injury.



CAUTION!

This symbol warns of possible injury.



NOTICE!

This symbol warns of possible damage to property.



This symbol gives additional information and hints.

1.3 About this translated version

This instruction for use contains important information about the choice of product or system, assembly and commissioning as well as intended use and, if required, maintenance measures. The information about the products, their properties and application technology are based on the current standards in Europe (e.g. EN) and/or in Germany (e.g. DIN/DVGW).

Some passages in the text may refer to technical codes in Europe/Germany. These should serve as recommendations in the absence of corresponding national regulations. The relevant national laws, standards, regulations, directives and other technical provisions take priority over the German/European directives specified in this manual: The information herein is not binding for other countries and regions; as said above, they should be understood as a recommendation.

2 Product information

2.1 Standards and regulations

The following standards and regulations apply to Germany / Europe and are provided as a support feature.

Regulations from section: Media

Scope / Notice	Regulations applicable in Germany
Rainwater	DIN 1886-100

2.2 Intended use

2.2.1 Areas of use

The Advantix rain hopper is intended for discharging rainwater from the roof drain.

2.2.2 Media

The Advantix rain hopper is intended for draining of rainwater in constant operation, see ↗ *'Regulations from section: Media'* on page 5.

It is not permitted to introduce wastewater which would damage the product material.

2.2.3 Drainage capacity

The drainage capacity is 6 l/s.

2.3 Product description

2.3.1 Overview

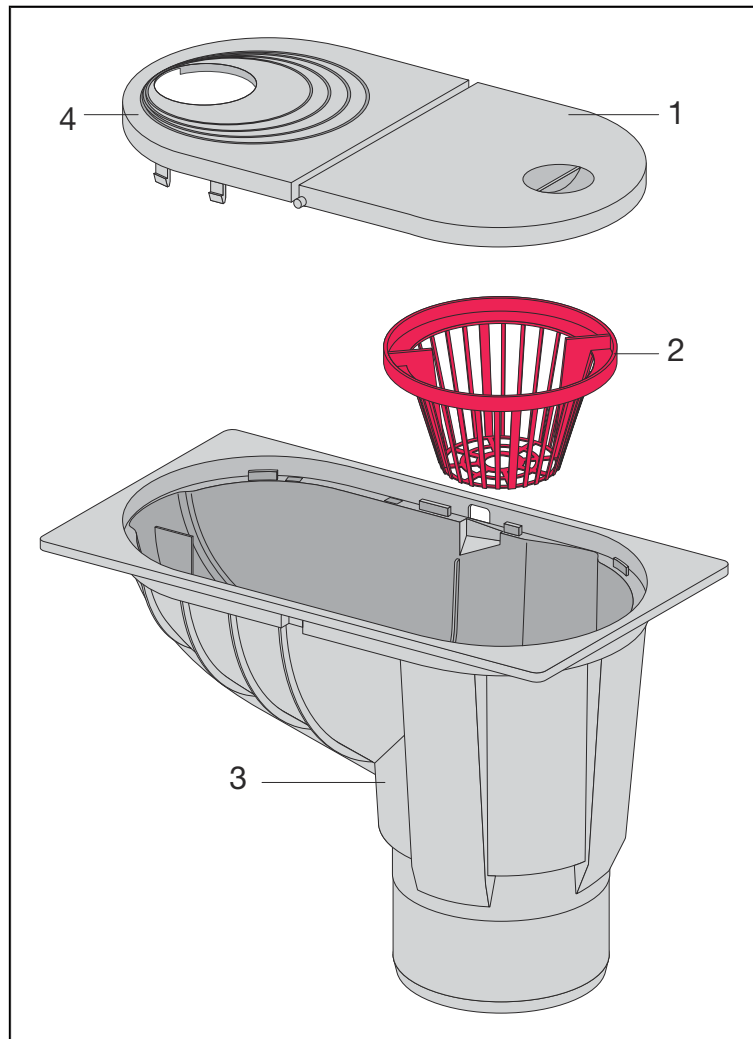

Fig. 1: Components rain hopper model 4970

- 1 cleaning flap
- 2 leaf trap
- 3 drain casing
- 4 Pipe lead-in

2.3.2 Technical data

Nominal width [DN] (drain socket)	100
Drainage capacity	↪ Chapter 2.2.3 'Drainage capacity' on page 5
Dimensions and installation height	↪ Chapter 3.1.2 'Installation dimensions' on page 8

2.4 Information for use

2.4.1 Installation variations

The rain hopper can be installed parallel with or at an angle of 90° to the wall.

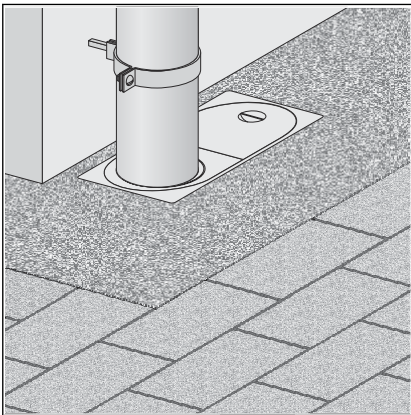

Fig. 2: Installation parallel to the wall

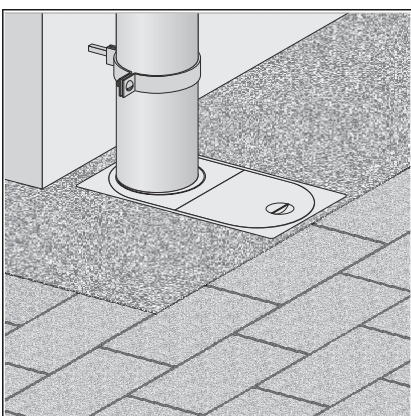

Fig. 3: Installation turned at an angle of 90°

3 Handling

3.1 Assembly information

3.1.1 Important note

Before assembly:

- Check if the drainage capacity is sufficient for the arising water volume ↪ *Chapter 2.2.3 'Drainage capacity' on page 5.*
- Ensure that the required connection line is installed with the necessary incline to the planned installation location.

During assembly:

- Observe installation dimensions.

After assembly:

- The drain casing must be fully lined.

3.1.2 Installation dimensions

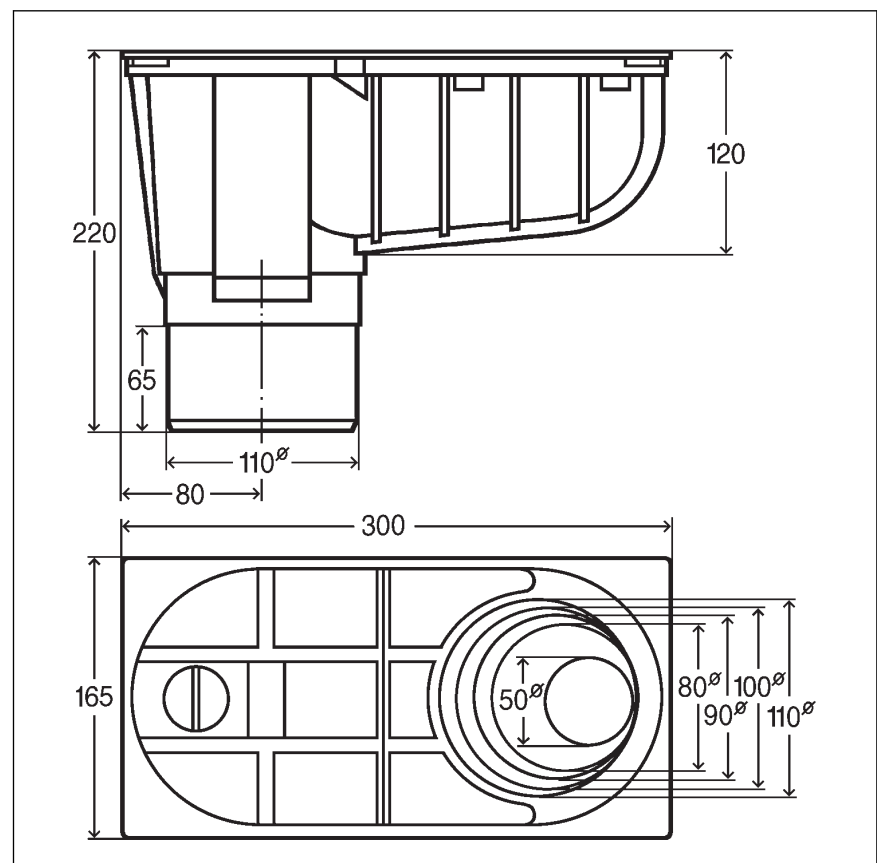

Fig. 4: Dimensional drawing for model 4970

3.2 Assembly

3.2.1 Connecting the drain

Requirements:

- A pipe to the planned drainage position is already in place for the connection to the wastewater system.
- The drainpipe has an internal sealing lip.
- Measure the diameter of the downpipe.

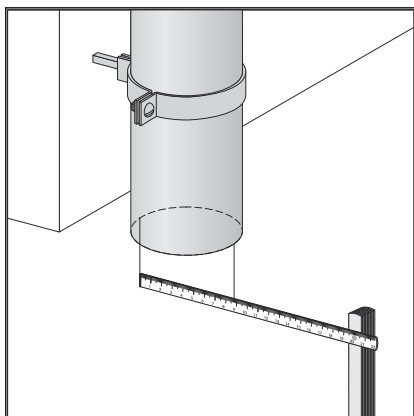

- Cut the pipe lead-in according to the diameter of the downpipe.

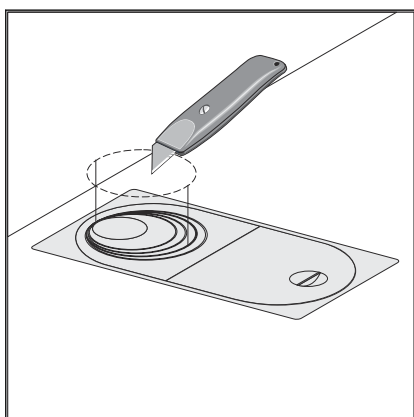

- Place the rain hopper in the floor and connect the wastewater pipe.

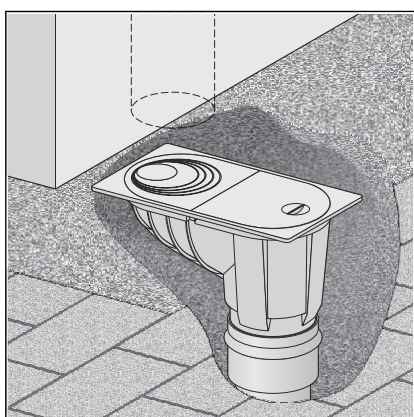

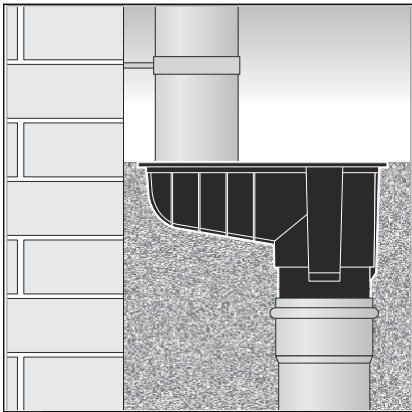

- ▶ Mount the rain hopper level with the surrounding surface and secure against sinking.

3.3 Care

3.3.1 Care tips

To maintain a consistent drainage capacity, the leaf trap must be emptied regularly.

3.4 Disposal

Separate the product and packaging materials (e. g. paper, metal, plastic or non-ferrous metals) and dispose of in accordance with valid national legal requirements.



Viega GmbH & Co. KG
service-technik@viega.de
viega.com

INT • 2022-08 • VPN200270

