

Instructions for Use

Advantix Cleviva shower channel base unit (reconstruction model)

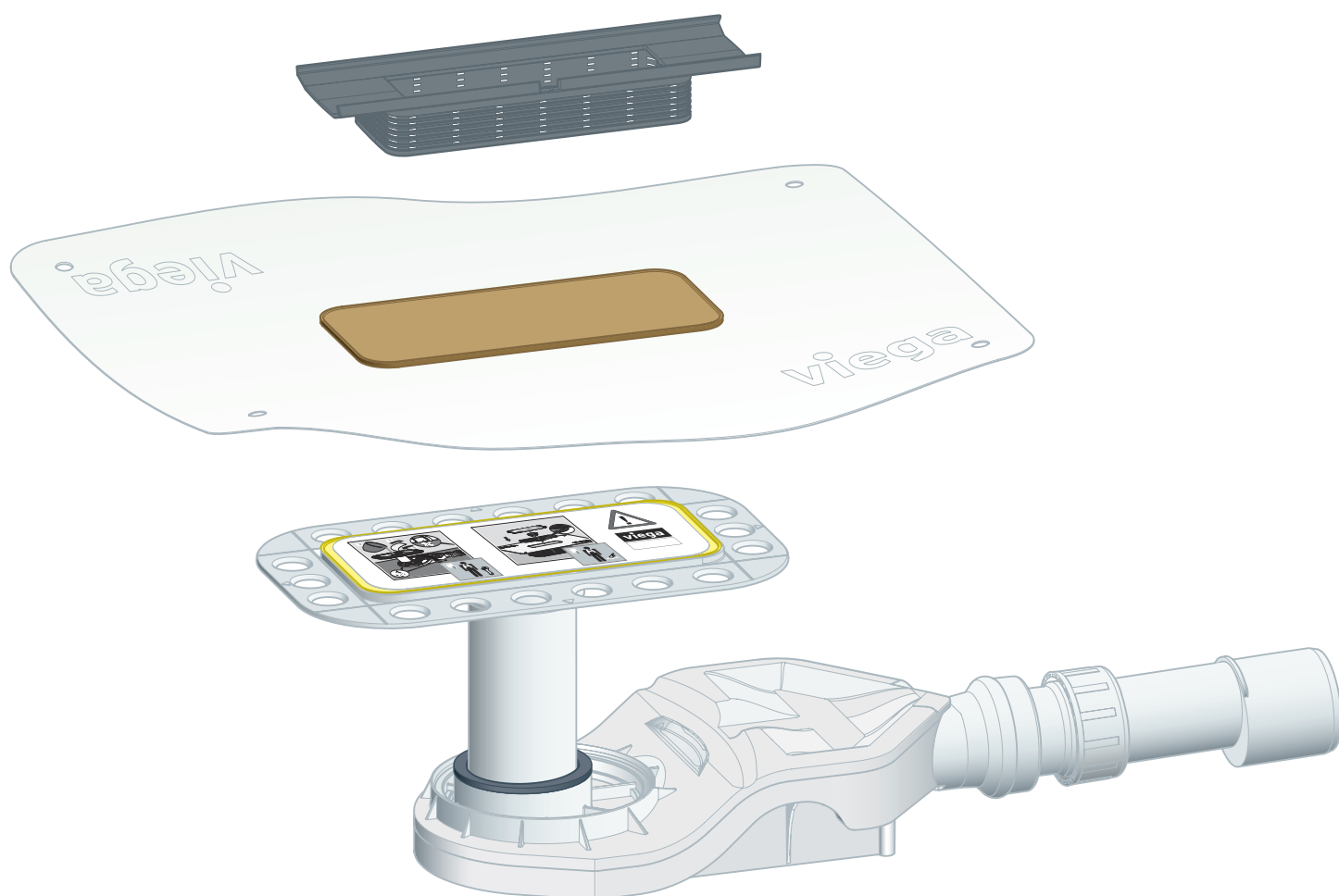

for bonded sealing (tiled shower).

Model
4981.81

Year built (from)
03/2019

viega

Table of contents

1	About these instructions for use	4
	1.1 Target groups	4
	1.2 Labelling of notes	4
	1.3 About this translated version	5
2	Product information	6
	2.1 Standards and regulations	6
	2.2 Intended use	7
	2.2.1 Areas of application	7
	2.2.2 Media	7
	2.2.3 Drainage capacity	7
	2.3 Product description	7
	2.3.1 Installation variations	7
	2.3.2 Overview of the components	8
	2.3.3 Technical data	8
	2.4 Information for use	9
	2.4.1 Sealing	9
	2.5 Accessories	11
3	Assembly	12
	3.1 Important note	12
	3.2 Tools and materials	12
	3.3 Installation dimensions	13
	3.4 Shortening the mounting flange	14
	3.5 Fitting the mounting flange	15
	3.6 Aligning and connecting	17
	3.7 Installation in tiled floors	23
	3.7.1 Sealing the shower channel	23
	3.7.2 Mounting height adjustment piece and shower channel profile	25
	3.8 Installation in self-levelling coating	32
	3.8.1 Sealing the shower channel	32
	3.8.2 Mounting height adjustment piece and shower channel profile	34
4	Care	41

4.1 Care tips	41
4.2 Cleaning	41
5 Disposal	42

1 About these instructions for use

Trade mark rights exist for this document; for further information, go to viega.com/legal.

1.1 Target groups

The information in this instruction manual is directed at the following groups of people:

- Heating and plumbing experts and trained personnel

Individuals without the abovementioned training or qualification are not permitted to mount, install and, if required, maintain this product. This restriction does not extend to possible operating instructions.

The installation of Viega products must take place in accordance with the general rules of engineering and the Viega instructions for use.

1.2 Labelling of notes

Warning and advisory texts are set aside from the remainder of the text and are labelled with the relevant pictographs.



DANGER!

This symbol warns of possible life-threatening injury.



WARNING!

This symbol warns of possible serious injury.



CAUTION!

This symbol warns of possible injury.



NOTICE!

This symbol warns of possible damage to property.



This symbol gives additional information and hints.

1.3 About this translated version

This instruction for use contains important information about the choice of product or system, assembly and commissioning as well as intended use and, if required, maintenance measures. The information about the products, their properties and application technology are based on the current standards in Europe (e.g. EN) and/or in Germany (e.g. DIN/DVGW).

Some passages in the text may refer to technical codes in Europe/Germany. These should serve as recommendations in the absence of corresponding national regulations. The relevant national laws, standards, regulations, directives and other technical provisions take priority over the German/European directives specified in this manual: The information herein is not binding for other countries and regions; as said above, they should be understood as a recommendation.

2 Product information

2.1 Standards and regulations

The following standards and regulations apply to Germany / Europe and are provided as a support feature.

Regulations from section: Sealing

Scope / Notice	Regulations applicable in Germany
Stress class of the underground, as well as suitable bonded sealing	Leitfaden zur Abdichtung im Verbund (AIV)
Approved bonded sealings with proof of practicability in keeping with building law for stress classes A and AO	ETAG 022 T1
Approved bonded sealings with proof of practicability in keeping with building law for stress classes A, B and C	DIBt-Bauregelliste A, Teil 2 des DIBt und Prüfgrundsätze für Abdichtungen im Verbund (PG AIV-F)
Permitted bonded sealings	EN 14891
Sealing of inside rooms	DIN18534

Regulations from section: Media

Scope / Notice	Regulations applicable in Germany
Typical domestic wastewater	DIN 1986-3

Regulations from section: Sound protection

Scope / Notice	Regulations applicable in Germany
Fulfilled noise protection requirements	DIN 4109
Fulfilled noise protection requirements	VDI 4100

Regulations from section: Important notes

Scope / Notice	Regulations applicable in Germany
Dimensions of slots and recesses	EN 1996

2.2 Intended use

2.2.1 Areas of application

The shower channel is used in the bathroom as a drain for a floor-level shower. The shower channel is dimensioned for small to medium volumes of water, such as those occurring in the residential building sector, for example.

Technical information, see ↗ *Chapter 2.3.3 'Technical data' on page 8.*

2.2.2 Media

The shower channel is intended for draining common household wastewater in constant operation, see ↗ *Chapter 2.1 'Standards and regulations' on page 6.*

- The short-term temperature of the wastewater may reach up to 95° C. The temperature must be considerably lower in constant operation.
- The pH value must be higher than four but lower than ten.

It is not permitted to introduce wastewater, which could damage the product material.

2.2.3 Drainage capacity

The water seal level is 25 mm.

Construction height 70 mm

Accumulation height	10 mm		20 mm	
	Sieve insert	with	does not include	with
Grate insert double slit	0.50 l/s	0.60 l/s	0.55 l/s	0.65 l/s
Grate insert straight slot	0.40 l/s	0.50 l/s	0.45 l/s	0.55 l/s

2.3 Product description

2.3.1 Installation variations

The length of the Cleviva shower channel can be adjusted.

The shower channel profile can be shortened to a length of 300 mm with millimetre precision.

2.3.2 Overview of the components

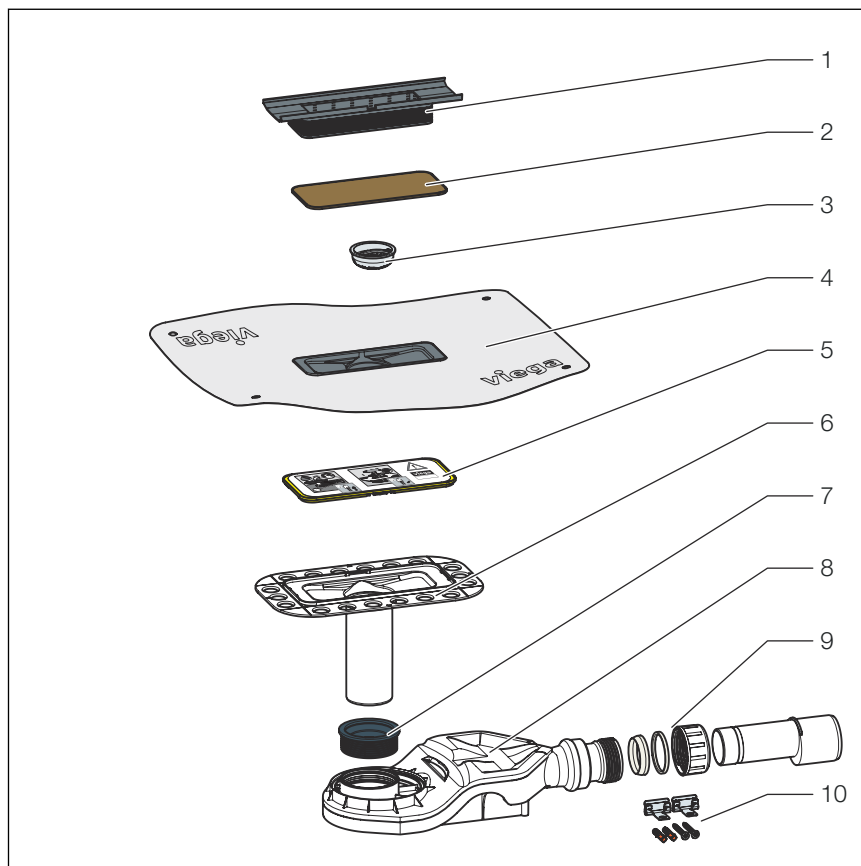

Fig. 1: Components and scope of delivery

- 1 Height adjustment piece
- 2 Site protection (composite wood)
- 3 Sieve insert
- 4 Sealing collar
- 5 Site protection (plastic)
- 6 Flange
- 7 Profile seal
- 8 Odour trap
- 9 Connection pipe DN 40/50
- 10 fixing set

2.3.3 Technical data

Nominal width [DN]	40 / 50
Material	Plastic odour trap Shower channel profile from stainless steel 1.4301
Drainage capacity	↪ Chapter 2.2.3 'Drainage capacity' on page 7
Dimensions and installation height	↪ Chapter 3.3 'Installation dimensions' on page 13

Water seal level	25 mm
Load class	K= 300 kg

2.4 Information for use

2.4.1 Sealing

Bonded sealing

To protect against moisture penetration, apply sealing foils, which are to be processed in liquid state, directly below the tiles on screed and walls. The determination of the stress class and the underground as well as the selection of the suitable bonded sealing must be carried out in compliance with the valid standards and regulations, see: ↗ *Chapter 2.1 'Standards and regulations' on page 6.*

Important note

Careful planning is required for sealing. In addition, depending on the individual dampness wear class and the type of foundation, a suitable thin bed bonded sealing with a building regulations certificate of suitability must be chosen.

Furthermore, the following factors should be taken into account:

- The drain or shower channel must be equipped with a special flange, which has an adhesive surface and a width of at least 50 mm.
- For bridging the material change from drain to screed, either a suitable sealing collar or sealing tape designed for overlapping with the thin bed bonded sealing over a width of at least 50 mm must be used.
- The screed must be laid at a minimum incline of 1–2%.
- The installation must be carried out in acc. with the mounting instructions and the manufacturer's information.

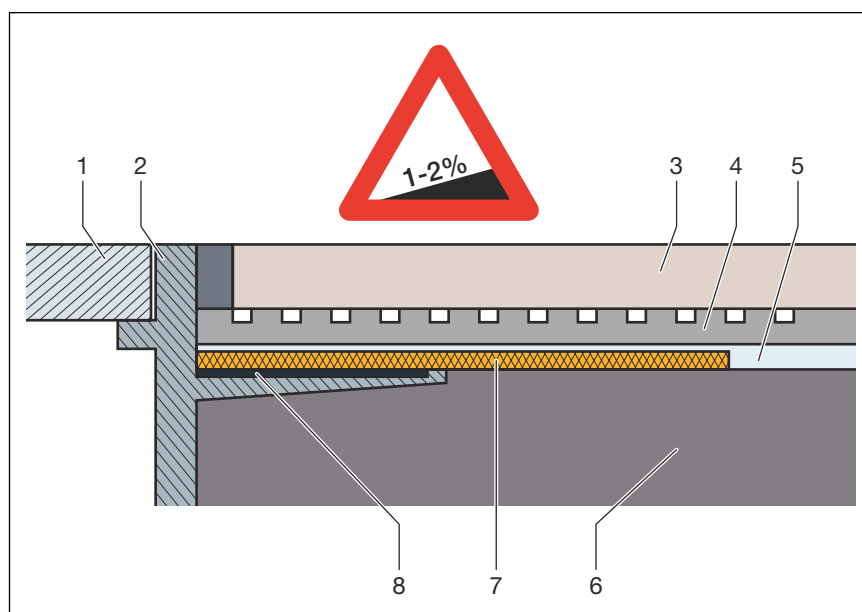

Fig. 2: Construction diagram of the bonded seal - min. screed incline 1–2 %

- 1 Grate
- 2 Top piece with adhesive flange
- 3 Tile
- 4 Tile cement
- 5 Bonded sealing
- 6 Screed
- 7 Sealing collar
- 8 Adhesive

Permitted bonded seals

In connection with suitable drains, only approved bonded sealings with proof of practicability in keeping with building law may be used. See [Chapter 2.1 'Standards and regulations'](#) on page 6.

Information regarding the procedure can be found in the instructions for use of the corresponding product.

2.5 Accessories

shower channel profile

For complete assembly of the shower channel base unit a shower channel inlay (model 4981.50 or 4981.60) and a shower channel profile (model 4981.30, 4981.31 or 4981.32) are also required.

Advantix sound protection element

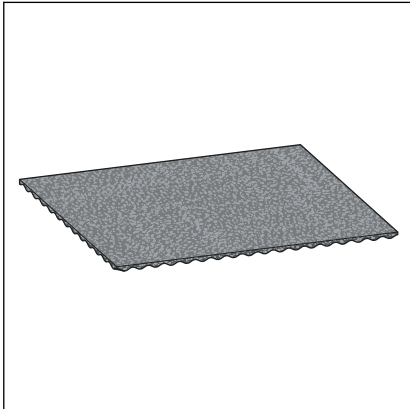

Article	790 448	791 650
Length (mm)	500	500
Width (mm)	350	350
Height (mm)	3	8

Fig. 3: Advantix sound protection element, model 4914.90

3 Assembly

3.1 Important note

Before assembly:

- Check if the drainage capacity of the model chosen is sufficient for the arising water volume ↪ *Chapter 2.2.3 'Drainage capacity' on page 7.*
- In the case of the connection of two or three shower channels: Observe the information for dimensioning of collective lines ↪ *Chapter 2.2.3 'Drainage capacity' on page 7.*
- An adequate level of floor covering stability must be guaranteed ↪ *Chapter 2.3.3 'Technical data' on page 8.* This can be achieved either through an adequate screed thickness or another alternative solution. Relevant measures must be considered before mounting.
- The dimensions of slots and recesses must be in compliance with the regulations from section ↪ *'Regulations from section: Important notes' on page 6.*

During assembly:

- Observe installation dimensions.
- Position the shower channel in such a way that the insert is removable.

After assembly:

- The shower channel must be fully lined with mortar.
- The sealing accessories should be given to the person responsible for the bonded sealing (e.g. tiler).
- Coordinate all relevant installation details, especially regarding the bonded sealing, with those responsible for the subsequent work.

3.2 Tools and materials

Special tools

- Hand saw (saw blade maximum 1.5 mm)
- Tool for removing the insert (e.g. model 4965.90, art. no. 689 704)

3.3 Installation dimensions

Shower channel, basic model with *one* base unit

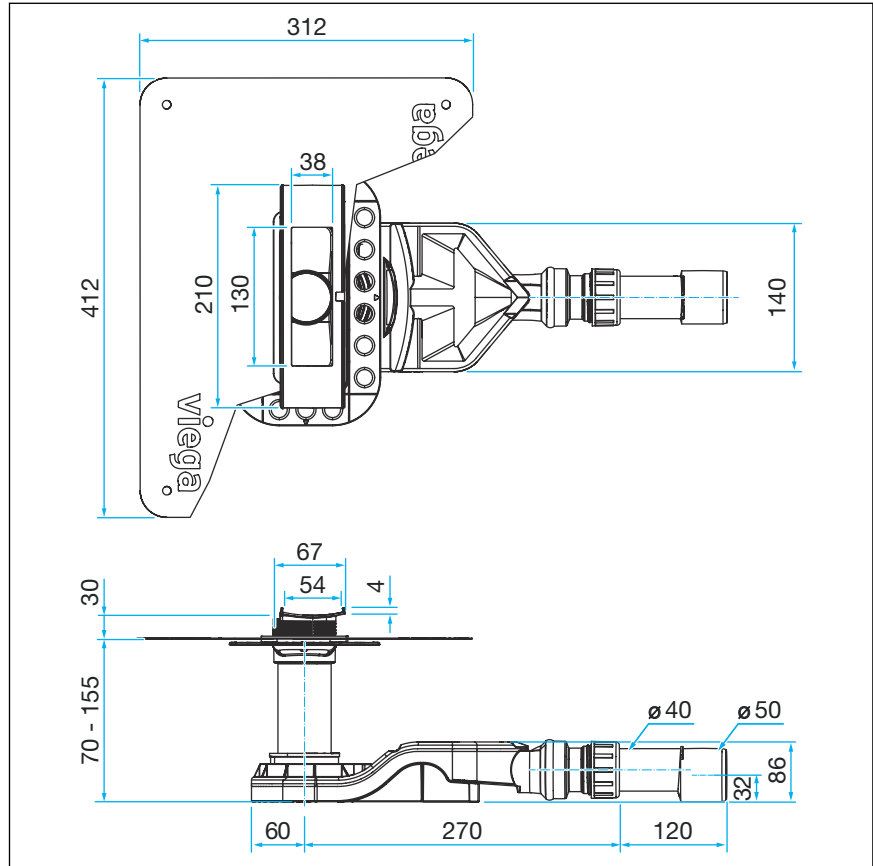

Fig. 4: Dimensions of base unit basic model

3.4 Shortening the mounting flange



The tiler set has to be handed over to the person responsible for the bonded sealing (tiler).

Determining the installation height

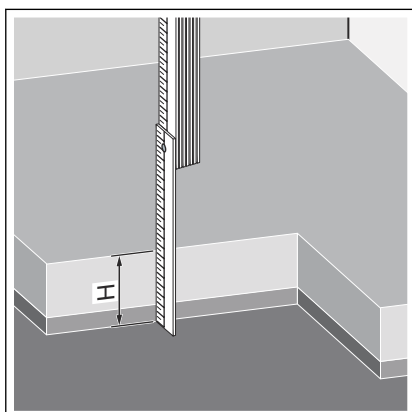

- Determine installation height H.
The installation height is 70–155 mm.

Shortening the mounting flange

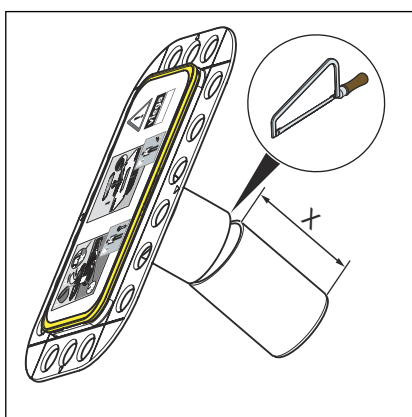

- Shorten the dimension X on the mounting flange.
 $X = 155 \text{ mm} - H$
- Deburr the mounting flange.



The height can be increased using a commercially available HT pipe DN50.

3.5 Fitting the mounting flange

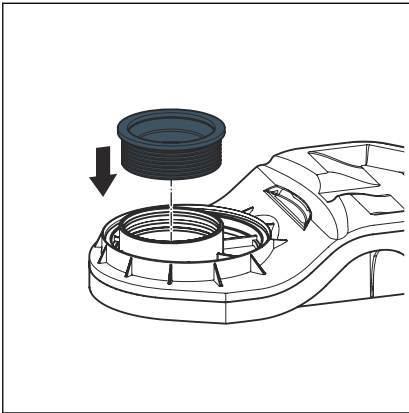

► Insert the profile seal.

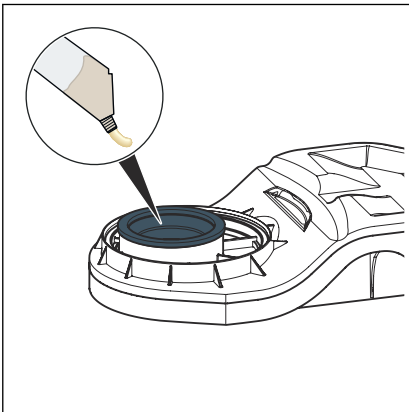

► Apply a coat of lubricant for plastic pipes to the inside of the profile seal.

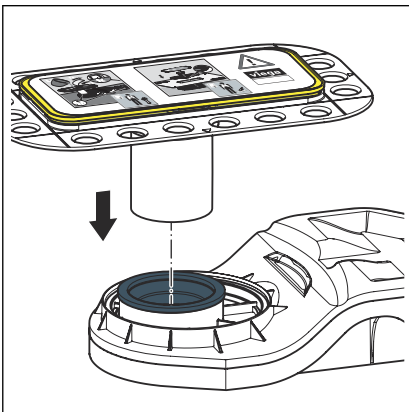

► Push the flange into the odour trap as far as it will go.

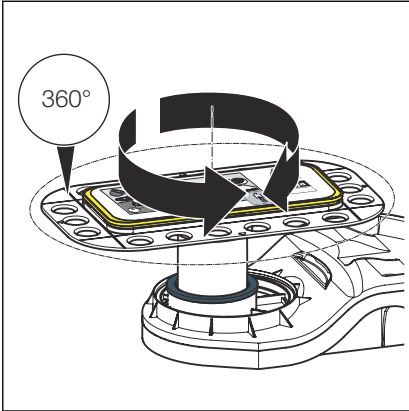

► The flange can be rotated around 360°.

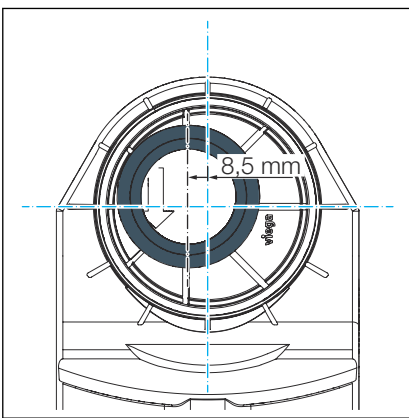

► Turn the transition to eccentrically offset the drain by up to 8.5 mm.

3.6 Aligning and connecting

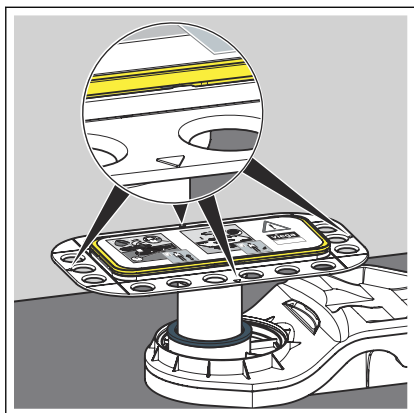

- Position the odour trap.

The arrows on the flange acts as alignment aids.

INFO! Fit a sound insulation mat beneath the odour trap as an option. Do not use retaining clips when using the sound insulation mat!

- 8 mm, art. no. 791 650
- 3 mm, art. no. 790 448

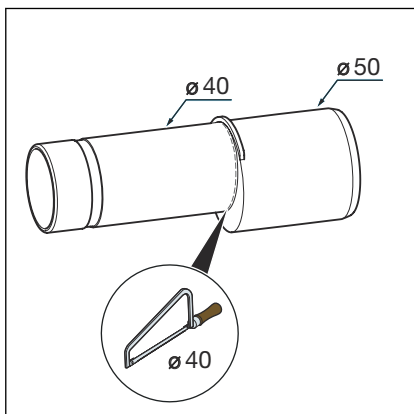

- Shorten the connection pipe as required.

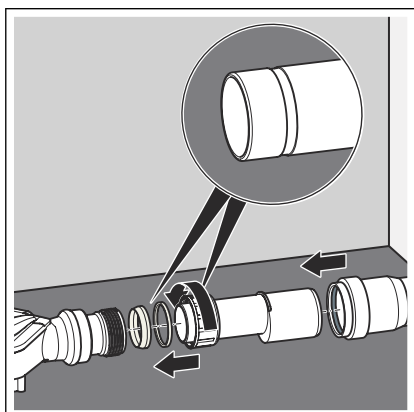

- Push the sliding ring and the wedge seal onto the connection pipe.
- Position the wedge seal on the groove.
- Screw the connection pipe to the odour trap using the union nut.
- Connect the drain to the wastewater system.

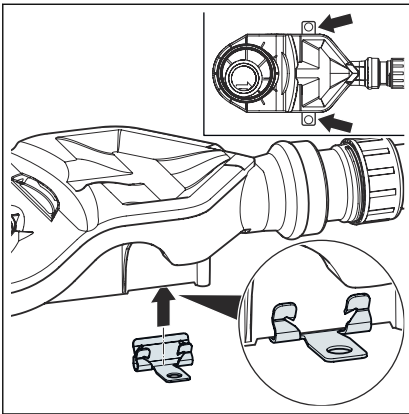

► Attach the retaining clamps.

INFO! Do not use retaining clips when using the sound insulation mat!

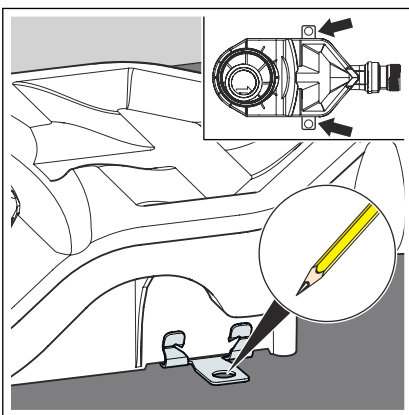

► Mark the fixing points on the floor.

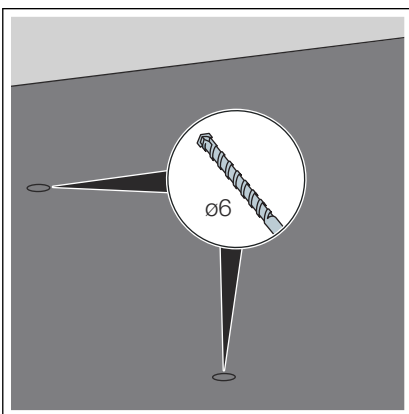

► Drill the holes.

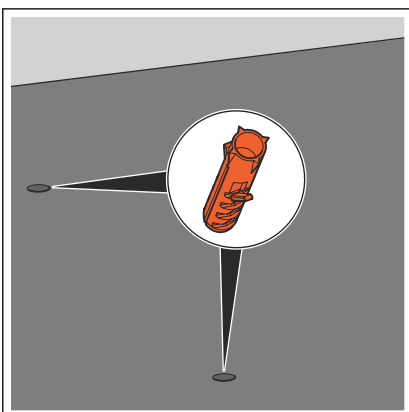

► Insert the dowels.

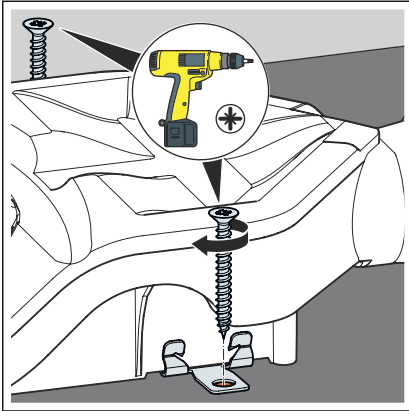

► Screw the retaining clamps in the floor.

Wall mounting



Can be installed only in front of a plastered wall or a prefabricated wall.

The distances to the shower channel profile depend on the positioning of the odour trap.

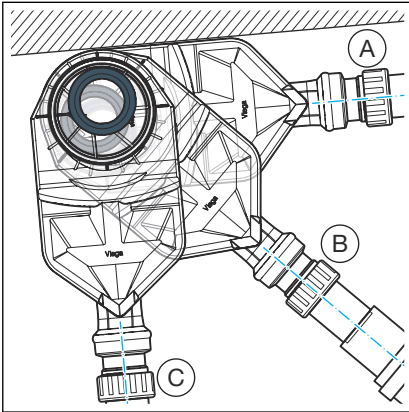
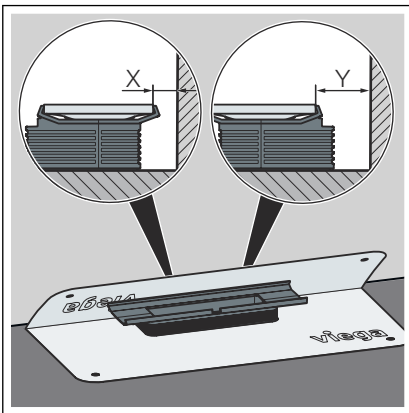

Fig. 5: Interval to wall, odour trap model 4981.11 / 4981.81



- X = minimum interval to wall
- Y = maximum interval to wall

Interval to wall, odour trap model 4981.11 / 4981.81

interval	A	B	C
Minimum X	27–31 mm	16–20 mm	14–18 mm
Maximum Y	36–40 mm	25–29 mm	23–24 mm

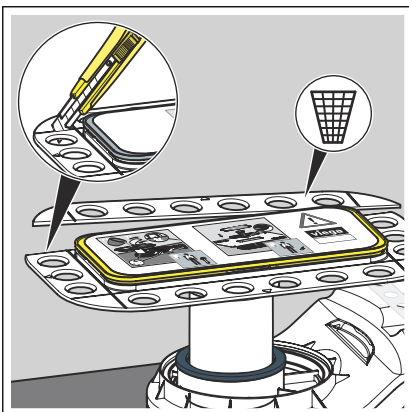

- Cut the side of the reinforcement area on the wall with a blade.
The flooring height (bonded sealing + adhesive + tiles) must not exceed 30 mm.

check for leaks

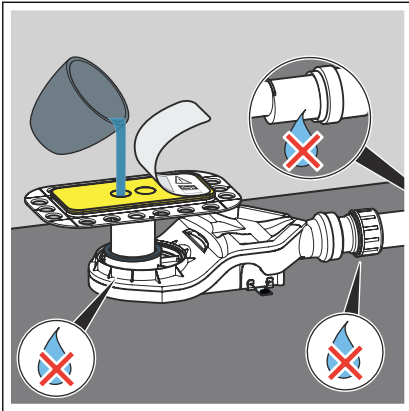

- Lift up the label.
- Fill the drain unit with water.
- Check the drain casing and the connection line for leaks.
- Re-affix the label.

Lining with screed

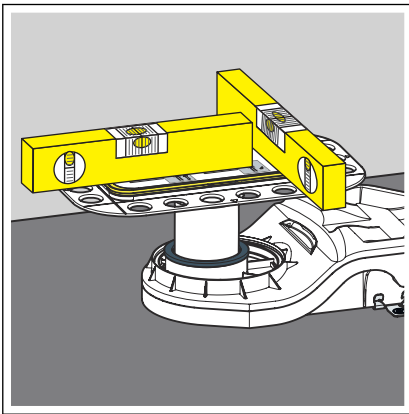

- Align the flange horizontally in all directions.

NOTICE!
Product damage due to improper installation

If cavities form during the lining of the shower channel, leaks may occur when pressure is applied.

Inform the subsequent workers that the shower channel must be fully lined and that there must be no cavities generated.



The screed and floor tiles must be laid at an incline of 1–2 % in the direction of the shower channel.

Requirement:

- The site protection has been mounted.
- Line the shower channel with screed.
- Fill with screed to the upper edge of the site protection.

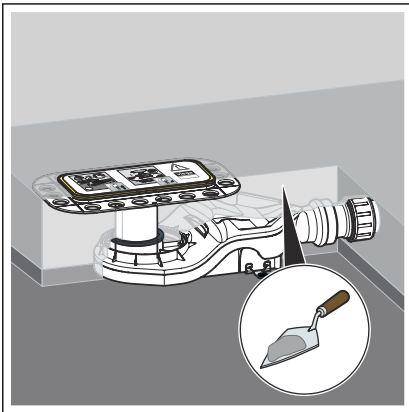

3.7 Installation in tiled floors

3.7.1 Sealing the shower channel



- The seal set has to be handed over to the person responsible for the bonded sealing (tiler).
- Only use the sealing accessories included in the scope of delivery.
- For wall mounting, work the sealing collar on the upright wall into the bonded sealing.

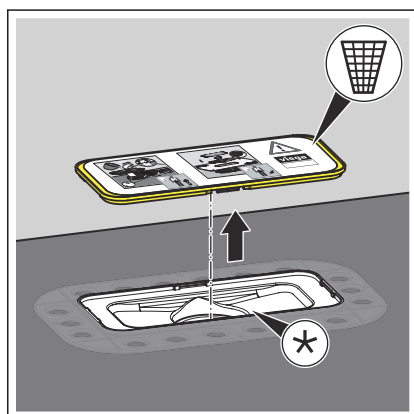

- Remove and dispose of the pre-mounted site protection.
The flange must be clean and free from material residue.

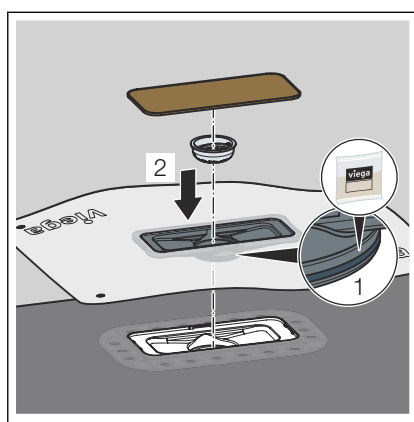

- Grease the sealing element.
- Clip the sealing collar into the flange.
- Check that the sealing element is properly positioned.
- Fit the sieve insert.
- Insert the wooden site protection.

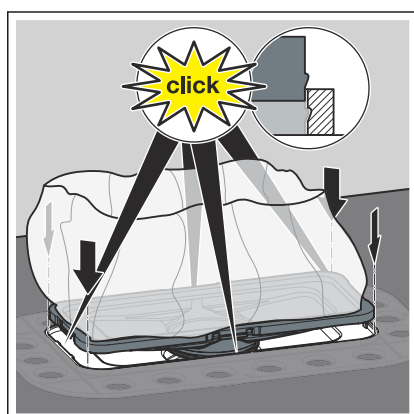

- Push the sealing collar into the flange as far as it will go.
All four fixing points must engage.

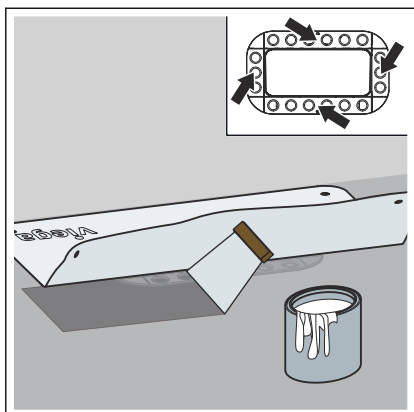

INFO! Observe the bonded sealing manufacturer's instructions for use.

- Fold together the sealing collar.
- Apply the first layer of bonded sealing generously onto the screed and the flange.
- Push the sealing collar in the still liquid bonded sealing, without wrinkles.

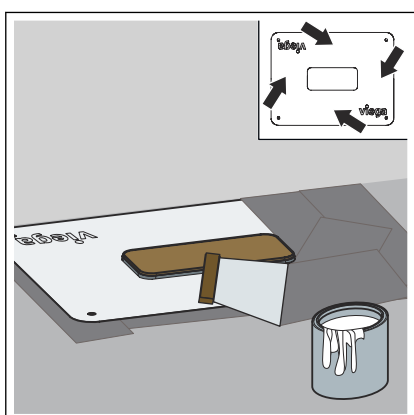

- Once the first layer has dried, apply the second layer of the bonded sealing generously onto the sealing collar and screed.

3.7.2 Mounting height adjustment piece and shower channel profile

Determining dimensions



The shower channel profile can be shortened.

Coloured profiles can be likewise shortened. When the coloured profile (PVD-coated) is shortened, the stainless steel base material is visible at the cut edges. Mount the shortened profile so that the cut edge is not visible.

The shower channel profile is divided into two drain zones.

- 1 Drain zone (flat, no incline)
- 2 Drain zone (with internal incline)

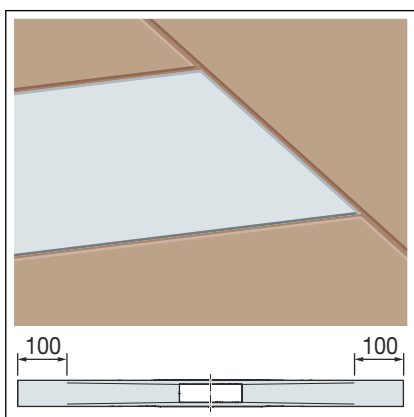
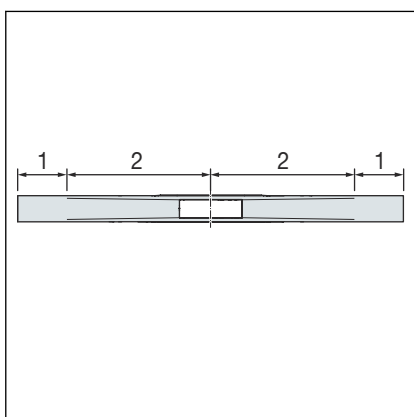

The shower channel profile can be shortened by up to 100 mm at the ends of the drain zone.

To be able to achieve individual profile lengths, the shower channel profile and the tiles are at the same height.

Shortening range of drain zone

Profile length	Shortening range
800 mm	600–800 mm
1000 mm	800–1000 mm
1200 mm	1000–1200 mm

* Offset between shower channel profile and tile

In the drain zone, the shower channel profile can be shortened to a minimum installation length of 150 mm from centre of the drain.

The resultant offset between the shower channel profile and the tile can be closed with a tile end rail or with silicon.

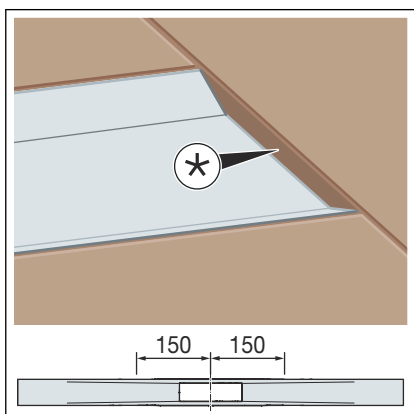

If channel solutions >1200 mm are required, the standard lengths of 800, 1000 and 1200 mm can be combined with one another.

To avoid an offset when laying several profiles, shorten the profiles only at the drain zone (max. 100 mm).

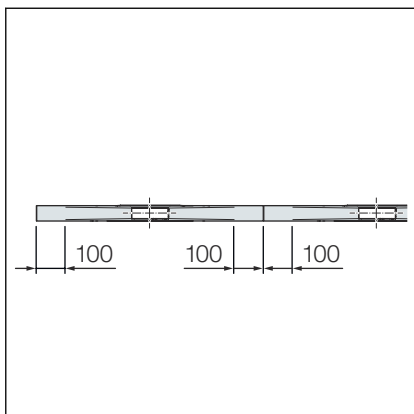

Shortening range of drain zone for extended shower channel profiles

Profile length	Shortening range
2 x 800 mm	1200–1600 mm
2 x 1000 mm	1600–2000 mm
2 x 1200 mm	2000–2400 mm

Shortening the shower channel profile

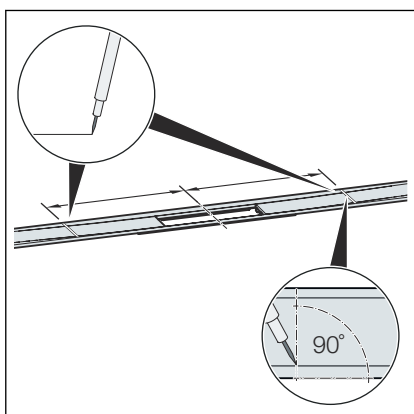

- Determine the required dimension and mark at right angles.

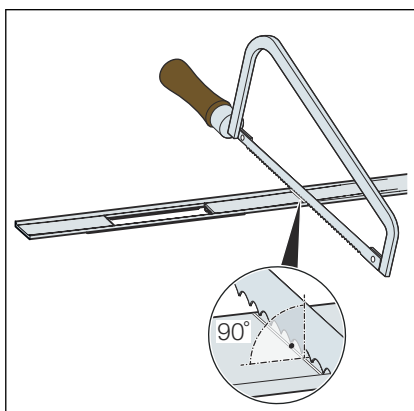

- Using a handsaw, shorten the shower channel profile at right angles and deburr.

Alternatively, the shower channel profile can be shortened using an electric metal slitting disc or a speed-restricted angle grinder with suitable stainless steel slitting disc.

NOTICE! To prevent corrosion, the tools must not have been used beforehand for processing ferrous materials.

Mounting the shower channel profile

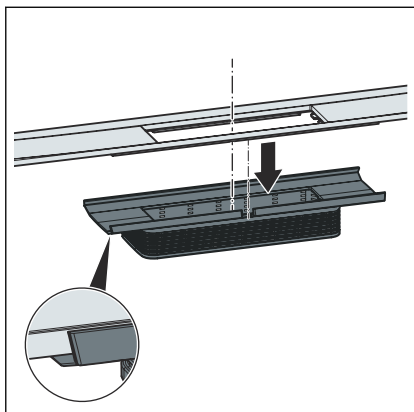

- Insert the shower channel profile into the height adjustment piece as far as it will go.

Make sure that shower channel profile protrusion sits exactly in the recess of the height adjustment piece.

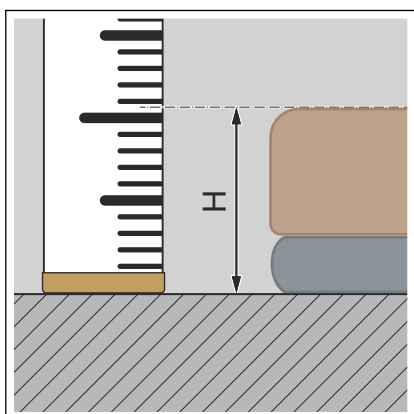

- Determine the flooring height H.

INFO! For fault-free drainage, Viega recommends laying the floor covering 1–2 mm higher than the shower channel profile.

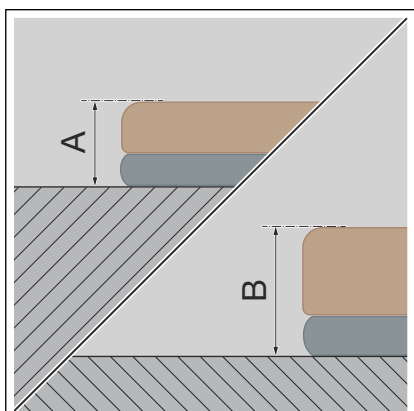

- Due to the stepless shortening of the top, an installation height of at least A 12 mm to B 30 mm is possible for tiles and tile adhesive.

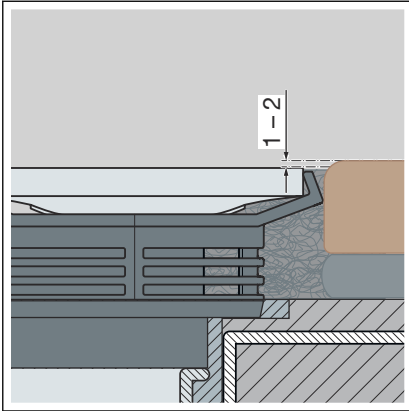

- Lay the floor covering 1–2 mm higher than the shower channel profile.

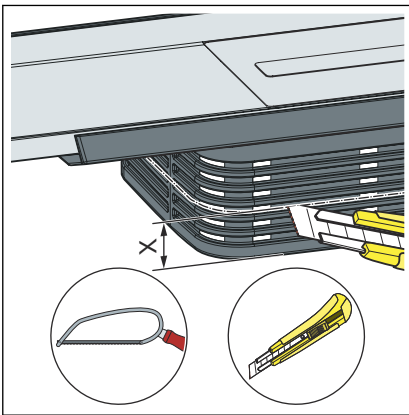

- Dimension $X = 30 \text{ mm} - H$
Shorten dimension X along the cutting aid and deburr.

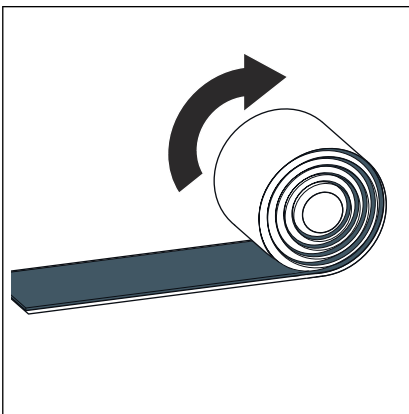

- Unroll the butyl tape and cut to size.

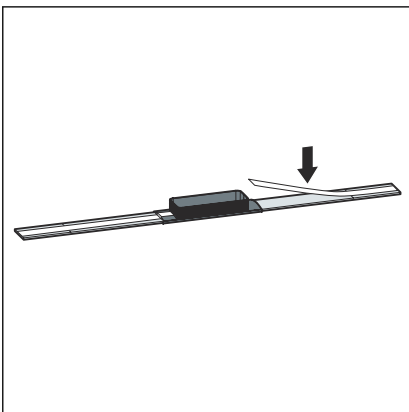

- Stick the butyl tape centrally on the underside of the shower channel profile.

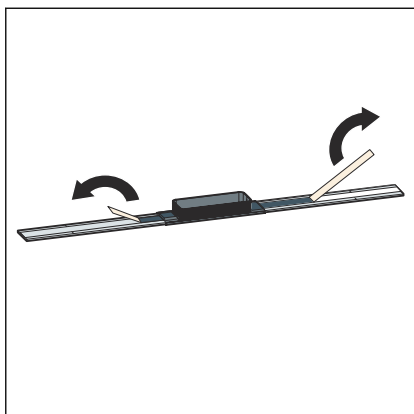

- Remove the protective cover.

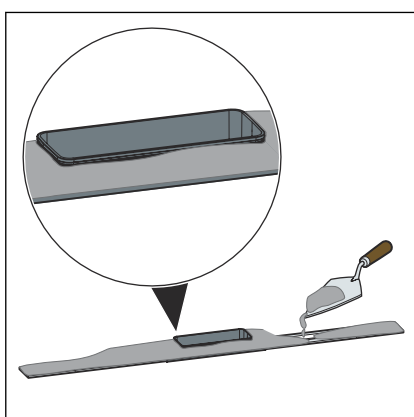

NOTICE! The flexural strength of the tile adhesive must conform to at least Class S1.

- Apply the tile adhesive over the entire underside of the shower channel profile and the height adjustment piece.

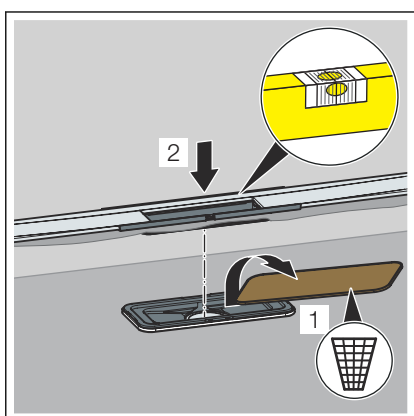

- Remove the wooden site protection.
Do not damage the bonded sealing.
- Insert the shower channel profile and the height adjustment piece.

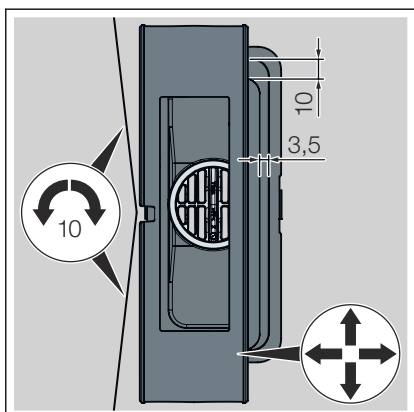

- Align the shower channel profile and the height adjustment piece horizontally.
 - The shower channel profile can be radially rotated by max. 10 mm (with a 1200 mm shower channel profile).
 - To adjust the shower profile to the tile pattern, the height adjustment piece can be moved on the long side by 3.5 mm and on the head side by 10 mm.

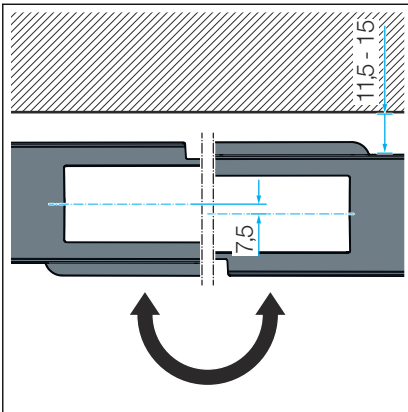

- The shower channel profile can be offset by 11.5–15 mm by rotating the top through 180°.

After alignment, fasten the height adjustment piece with tile adhesive.

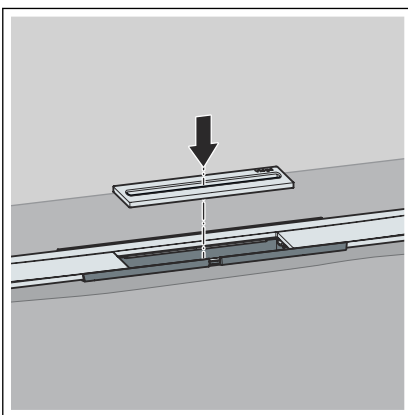

- Fit the shower channel inlay.

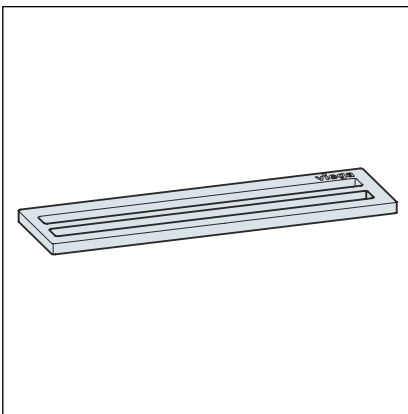

Two insert variants are available:

- Inlet opening double, model 4981.60

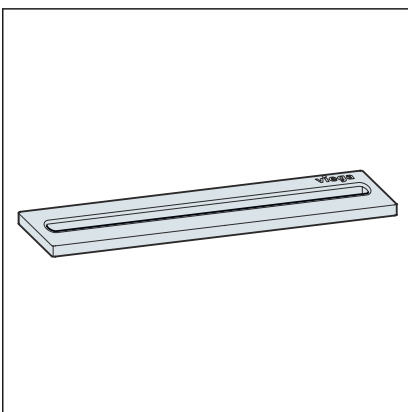

- Inlet opening single, model 4981.50

Laying the floor tiles

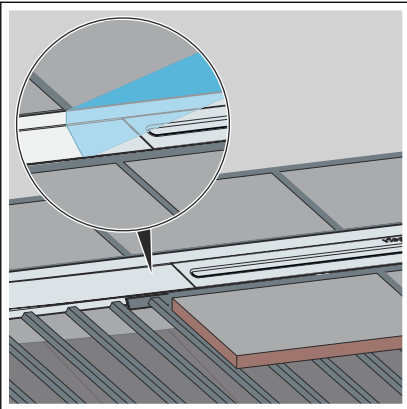

- Apply the tile adhesive.
- Lay the floor tiles up to the shower channel profile.
- Seal any gaps between tile and grate element with a suitable filler material or joint filler.
- Remove the protective cover from coloured profiles.

3.8 Installation in self-levelling coating

3.8.1 Sealing the shower channel



- The seal set has to be handed over to the person responsible for the self-levelling coating (tiler).
- Only use the sealing accessories included in the scope of delivery.
- For wall mounting, work the sealing collar on the upright wall into the self-levelling coating or the bonded sealing.

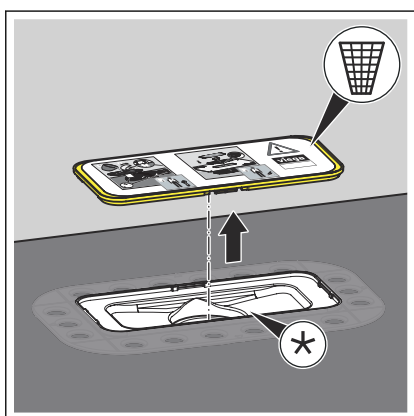

- Remove and dispose of the pre-mounted site protection. The flange must be clean and free from material residue.

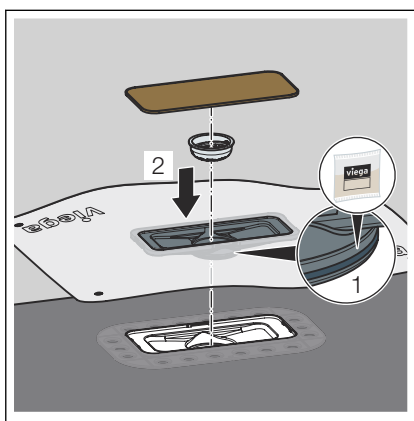

- Grease the sealing element.
- Clip the sealing collar into the flange.
- Check that the sealing element is properly positioned.
- Fit the sieve insert.
- Insert the wooden site protection.

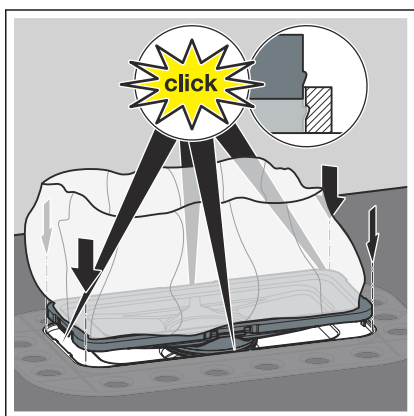

- Push the sealing collar into the flange as far as it will go. All four fixing points must engage.

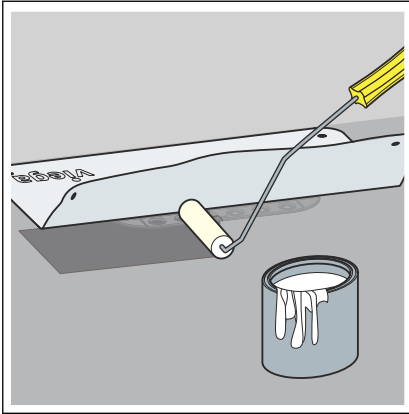

INFO! Observe the usage notes of the self-levelling coating manufacturer.

- Fold together the sealing collar.
- Prime the screed with the first layer of primer (e.g. with Arturo EP).
- Push the sealing collar in the still liquid primer without wrinkles.

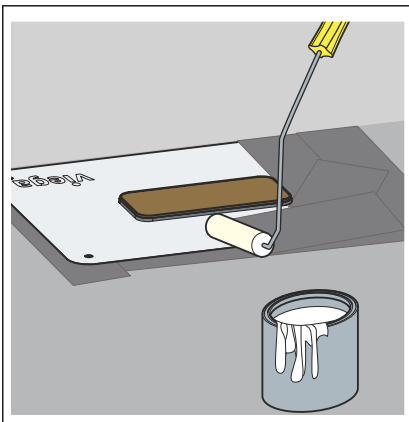

- Once the first layer has dried, apply the second layer of primer generously onto the sealing collar and screed.

3.8.2 Mounting height adjustment piece and shower channel profile

Determining dimensions



The shower channel profile can be shortened.

Coloured profiles can be likewise shortened. When the coloured profile (PVD-coated) is shortened, the stainless steel base material is visible at the cut edges. Mount the shortened profile so that the cut edge is not visible.

The shower channel profile is divided into two drain zones.

- 1 Drain zone (flat, no incline)
- 2 Drain zone (with internal incline)

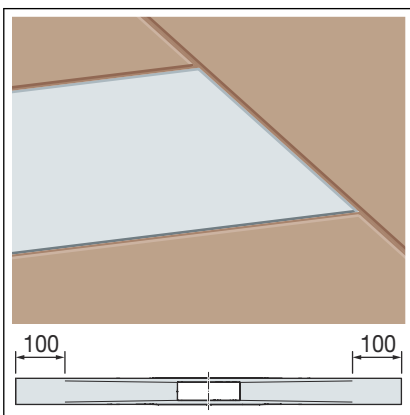
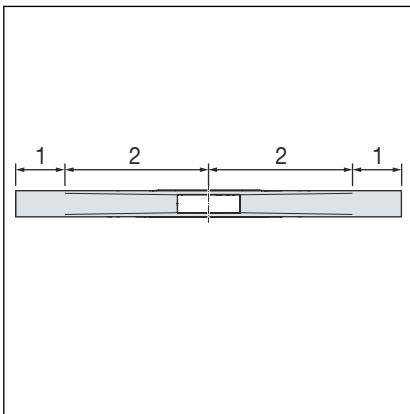

The shower channel profile can be shortened by up to 100 mm at the ends of the drain zone.

To be able to achieve individual profile lengths, the shower channel profile and the tiles are at the same height.

Shortening range of drain zone

Profile length	Shortening range
800 mm	600–800 mm
1000 mm	800–1000 mm
1200 mm	1000–1200 mm

* Offset between shower channel profile and tile

In the drain zone, the shower channel profile can be shortened to a minimum installation length of 150 mm from centre of the drain.

The resultant offset between the shower channel profile and the tile can be closed with a tile end rail or with silicon.

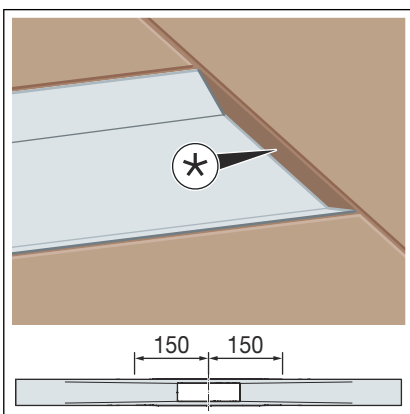

If channel solutions >1200 mm are required, the standard lengths of 800, 1000 and 1200 mm can be combined with one another.

To avoid an offset when laying several profiles, shorten the profiles only at the drain zone (max. 100 mm).

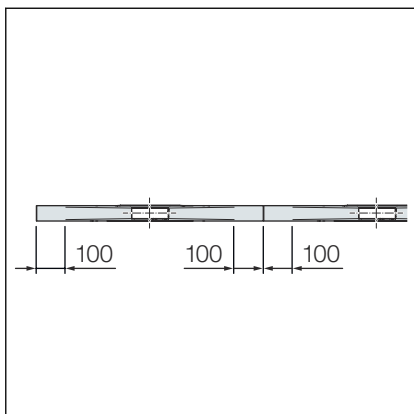

Shortening range of drain zone for extended shower channel profiles

Profile length	Shortening range
2 x 800 mm	1200–1600 mm
2 x 1000 mm	1600–2000 mm
2 x 1200 mm	2000–2400 mm

Shortening the shower channel profile

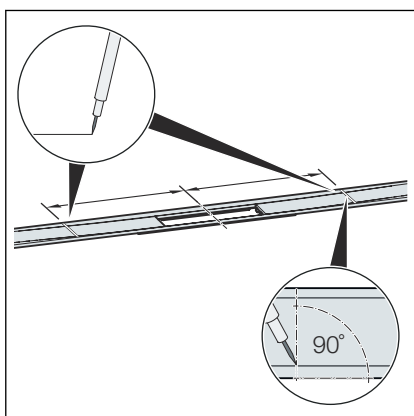

- Determine the required dimension and mark at right angles.

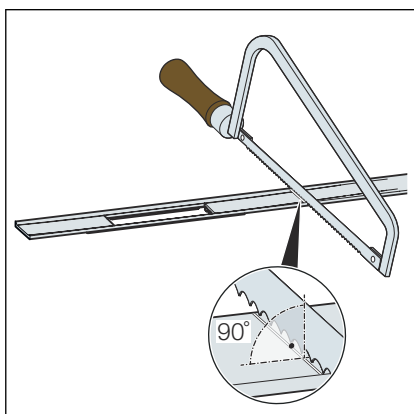

- Using a handsaw, shorten the shower channel profile at right angles and deburr.

Alternatively, the shower channel profile can be shortened using an electric metal slitting disc or a speed-restricted angle grinder with suitable stainless steel slitting disc.

NOTICE! To prevent corrosion, the tools must not have been used beforehand for processing ferrous materials.

Mounting the shower channel profile

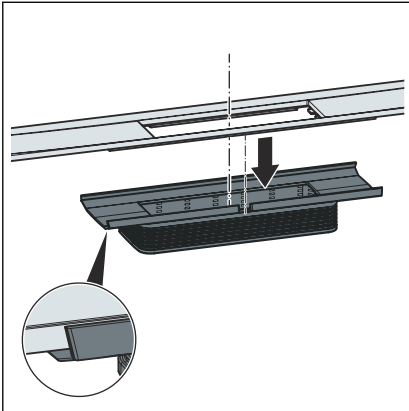

- Insert the shower channel profile into the height adjustment piece as far as it will go.

Make sure that shower channel profile protrusion sits exactly in the recess of the height adjustment piece.

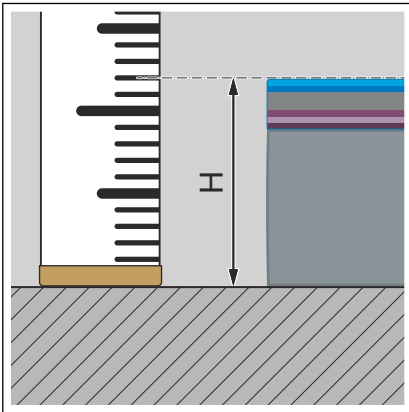

- Determine the flooring height H.

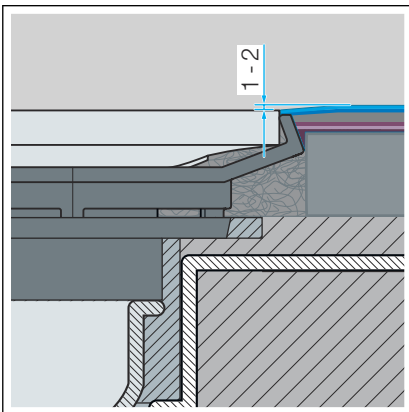

INFO! For fault-free drainage, Viega recommends laying the floor covering 1–2 mm higher than the shower channel profile.

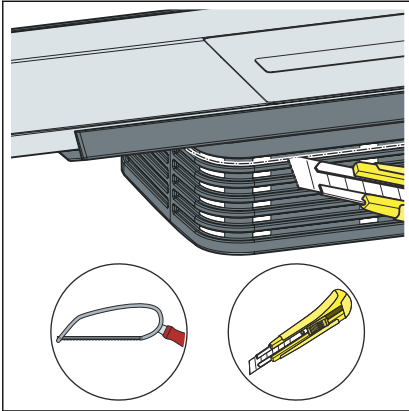

► Cut the height adjustment piece to the length of 12 mm and deburr.

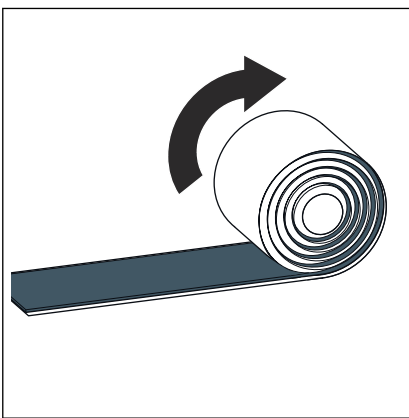

► Unroll the butyl tape and cut to size.

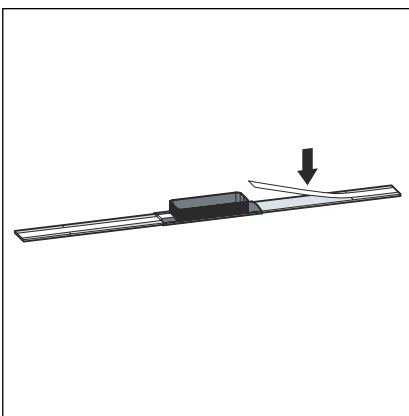

► Stick the butyl tape centrally on the underside of the shower channel profile.

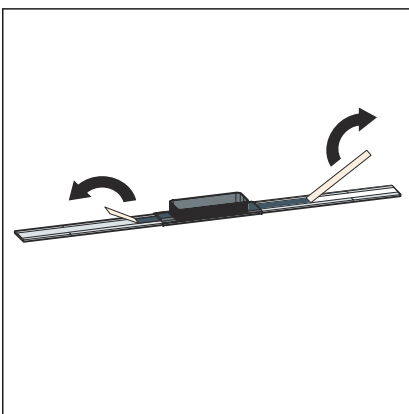

► Remove the protective cover.

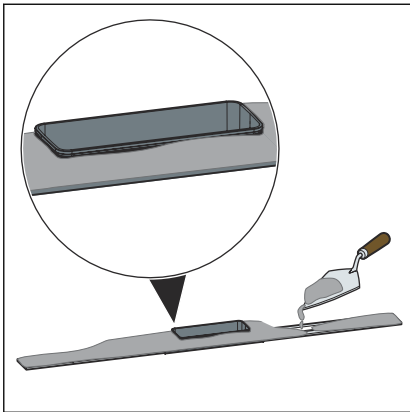

NOTICE! The flexural strength of the tile adhesive must conform to at least Class S1.

- Apply the tile adhesive over the entire underside of the shower channel profile and the height adjustment piece.

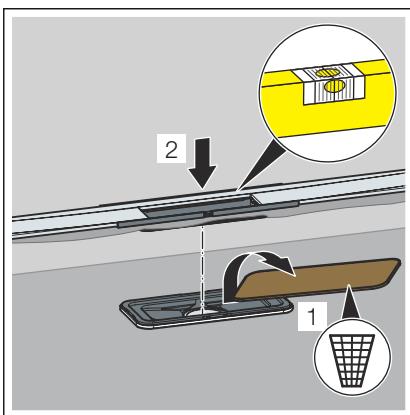

- Remove the wooden site protection.
- Insert the shower channel profile and the height adjustment piece.
- To prevent the scratch filler or self-levelling coating from running in, seal the area between height adjustment piece and drain with tile adhesive.
- Remove excess tile adhesive that has squeezed out at the sides of the profile.

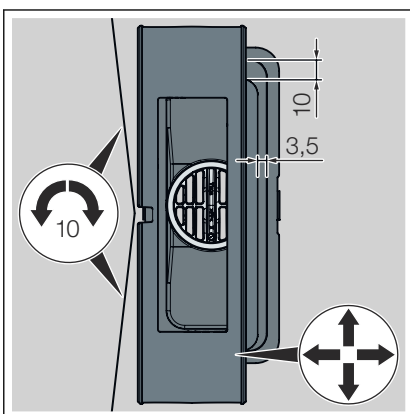

- Align the shower channel profile and the height adjustment piece horizontally.
 - The shower channel profile can be radially rotated by max. 10 mm (with a 1200 mm shower channel profile).
 - To adjust the shower profile to the tile pattern, the height adjustment piece can be moved on the long side by 3.5 mm and on the head side by 10 mm.

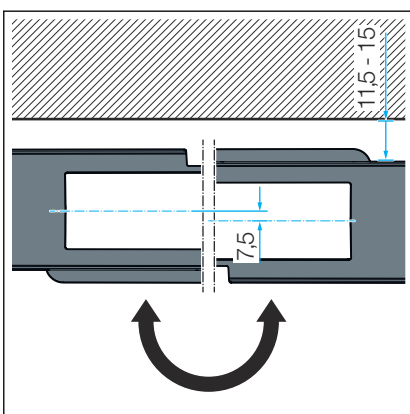

- The shower channel profile can be offset by 11.5–15 mm by rotating the top through 180°.

After alignment, fasten the height adjustment piece with tile adhesive.

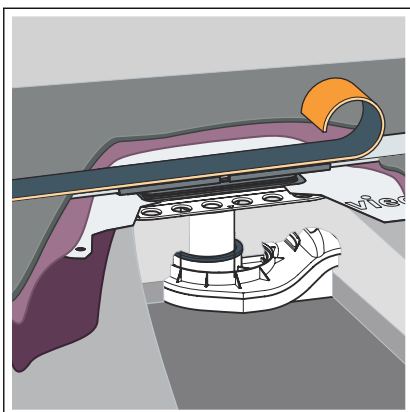

- To prevent the self-levelling coating being applied to the profile, mask the profile (e.g. with foam rubber tape or XPS foam sheet).
- Apply the scratch filler (e.g. Arturo EP) according to the manufacturer's instructions. Completely integrate the profile into the scratch filler.

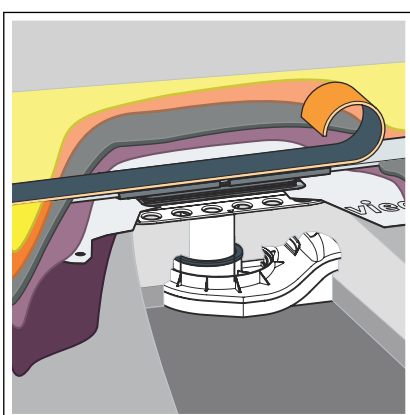

- Once the scratch coat has dried, apply the self-levelling coating and sealant (e.g. Arturo PU) according to the manufacturer's instructions.

INFO! To prevent water accumulating on the shower channel profile, apply the self-levelling coating 1–2 mm higher than the profile.

- When the self-levelling coating has cured, remove the foam rubber tape or XPS foam sheet from the profile.
- Deburr the edge at the transition to the profile and clean.

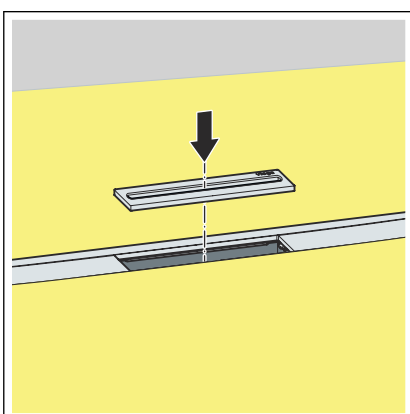

- Fit the shower channel inlay.

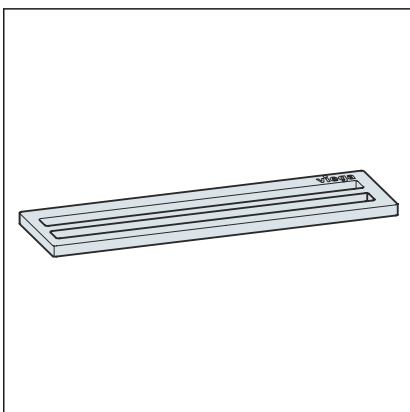

Two insert variants are available:

- Inlet opening double, model 4981.60

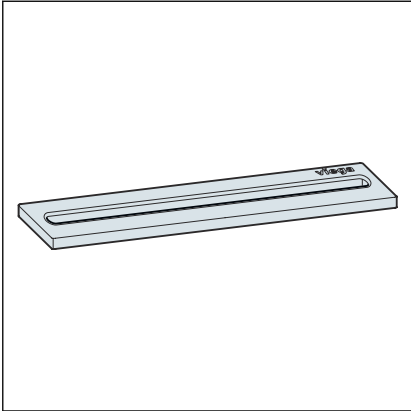

■ Inlet opening single, model 4981.50

4 Care

4.1 Care tips

Normal soap or a mild cleaning agent can be used for regular maintenance and prevention of lime scale on the grate and frame. Use no scouring agent or abrasive objects.

Strong stains, even around the drain unit and the odour trap, can be removed using typical household cleaner. Rinse the detergent very thoroughly with clear water after the prescribed dwell time. There should be no residue on the components.

4.2 Cleaning

Viega recommends using a mild cleaning agent, a cloth and a washing-up brush for cleaning.

Clean shower channel

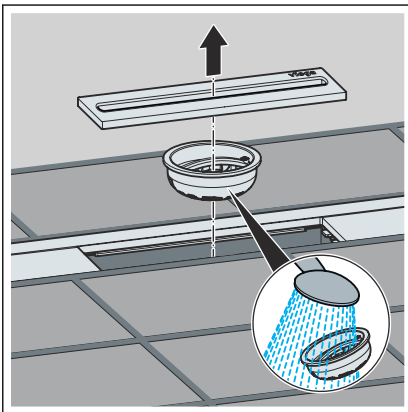

- Remove the shower channel insert and sieve.
- Clean the sieve.

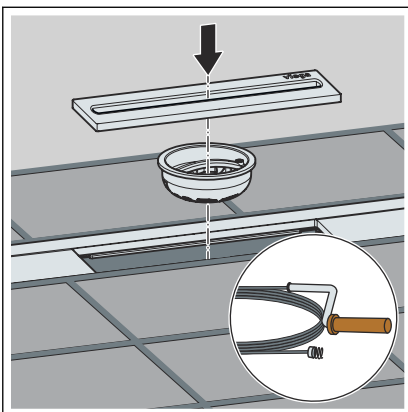

- Clean the odour trap.
- Replace the sieve and the shower channel insert.

5 Disposal

Separate the product and packaging materials (e. g. paper, metal, plastic or non-ferrous metals) and dispose of in accordance with valid national legal requirements.



Viega GmbH & Co. KG
service-technik@viega.de
viega.com

INT • 2024-07 • VPN240096

