

Instructions for Use

Easytop circulation regulation valve S/E with SC-Contur

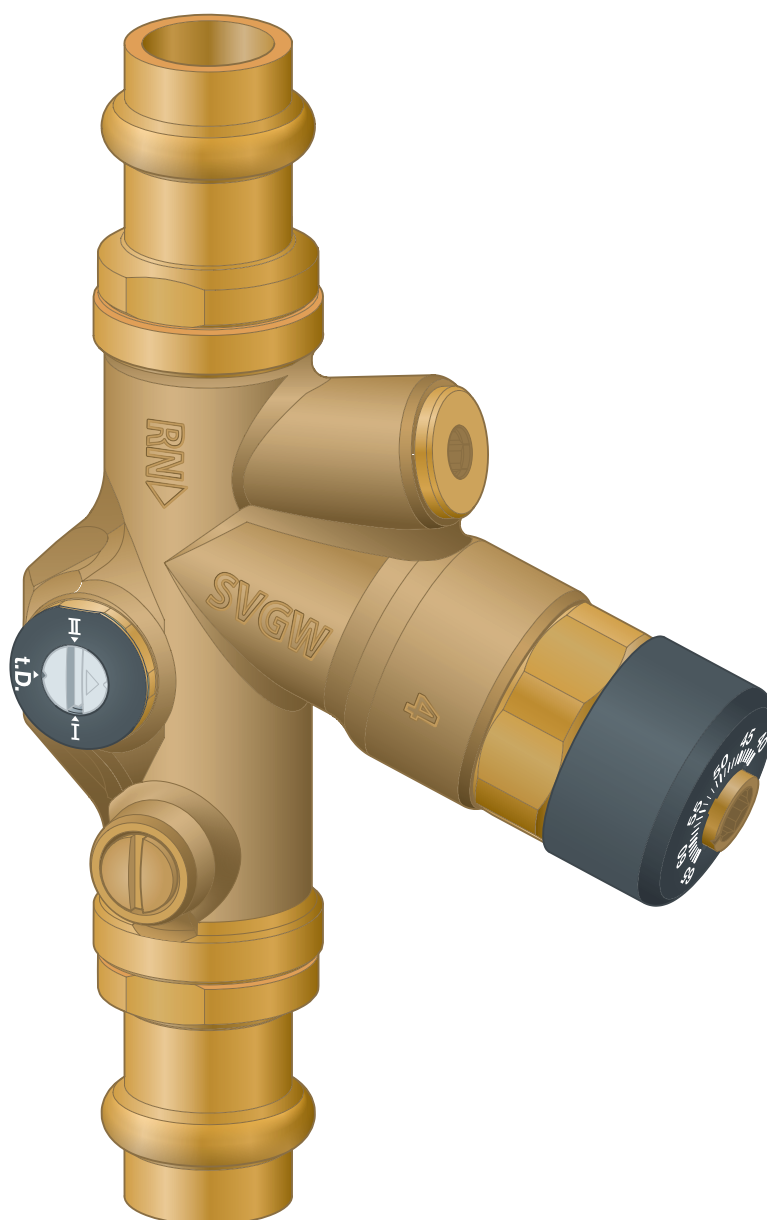

For thermal / hydraulic line calibration in potable water installations

Model
2281.7

Year built (from)
03/2019

viega

Table of contents

1	About these instructions for use	3
	1.1 Target groups	3
	1.2 Labelling of notes	3
	1.3 About this translated version	4
2	Product information	5
	2.1 Standards and regulations	5
	2.2 Intended use	7
	2.2.1 Areas of use	7
	2.2.2 Media	7
	2.3 Product description	8
	2.3.1 Overview	8
	2.3.2 Press connection with SC-Contur	8
	2.3.3 Sealing elements	9
	2.3.4 Markings on components	10
	2.3.5 Compatible components	10
	2.3.6 Operating mode	10
	2.3.7 Technical data	11
	2.4 Information for use	14
	2.4.1 Corrosion	14
	2.5 Optional accessories	14
3	Handling	16
	3.1 Assembly information	16
	3.1.1 Permitted exchange of sealing elements	16
	3.1.2 Mounting instructions	16
	3.1.3 Required tools	17
	3.2 Assembly	18
	3.2.1 Replacing the sealing element	18
	3.2.2 Shortening the pipes	19
	3.2.3 Pressing the connection	19
	3.2.4 Installation position and settings	21
	3.2.5 Mounting the Easytop drainage valve and Easytop thermometer	23
	3.2.6 Thermal disinfection	24
	3.2.7 Leakage test	25
	3.3 Maintenance	25
	3.4 Disposal	26

1 About these instructions for use

Trade mark rights exist for this document; for further information, go to viega.com/legal.

1.1 Target groups

The information in this manual is directed at heating and sanitary professionals and trained personnel.

Individuals without the abovementioned training or qualification are not permitted to mount, install and, if required, maintain this product. This restriction does not extend to possible operating instructions.

The installation of Viega products must take place in accordance with the general rules of engineering and the Viega instructions for use.

1.2 Labelling of notes

Warning and advisory texts are set aside from the remainder of the text and are labelled with the relevant pictographs.



DANGER!

This symbol warns of possible life-threatening injury.



WARNING!

This symbol warns of possible serious injury.



CAUTION!

This symbol warns of possible injury.



NOTICE!

This symbol warns of possible damage to property.



This symbol gives additional information and hints.

1.3 About this translated version

This instruction for use contains important information about the choice of product or system, assembly and commissioning as well as intended use and, if required, maintenance measures. The information about the products, their properties and application technology are based on the current standards in Europe (e.g. EN) and/or in Germany (e.g. DIN/DVGW).

Some passages in the text may refer to technical codes in Europe/Germany. These should serve as recommendations in the absence of corresponding national regulations. The relevant national laws, standards, regulations, directives and other technical provisions take priority over the German/European directives specified in this manual: The information herein is not binding for other countries and regions; as said above, they should be understood as a recommendation.

2 Product information

2.1 Standards and regulations

The following standards and regulations apply to Germany / Europe and are provided as a support feature.

Regulations from section: Fields of application

Scope / Notice	Regulations applicable in Germany
Planning, execution, operation and maintenance of potable water installations	DIN EN 806, part 1
Planning, execution, operation and maintenance of potable water installations	DIN EN 806, part 2
Planning, execution, operation and maintenance of potable water installations	DIN EN 806, part 3
Planning, execution, operation and maintenance of potable water installations	DIN EN 806, part 4
Planning, execution, operation and maintenance of potable water installations	DIN EN 806, part 5
Planning, execution, operation and maintenance of potable water installations	DIN EN 1717
Planning, execution, operation and maintenance of potable water installations	DIN 1988
Planning, execution, operation and maintenance of potable water installations	VDI/DVGW 6023
Planning, execution, operation and maintenance of potable water installations	Trinkwasserverordnung (TrinkwV)
Planning, execution, operation and maintenance of potable water installations	DVGW-Arbeitsblatt W 553

Regulations from section: Media

Scope / Notice	Regulations applicable in Germany
Suitability for drinking water	Trinkwasserverordnung (TrinkwV)

Regulations from section: Product description

Scope / Notice	Regulations applicable in Germany
Suitability for potable water installations	Trinkwasserverordnung (TrinkwV)
Suitability for potable water installations	DIN 50930-6
Requirements in plastic components in potable water installations	DVGW-Arbeitsblatt W270

Regulations from section: Compatible components

Scope / Notice	Regulations applicable in Germany
Permitted pipe types	DVGW-Arbeitsblatt W 534
Permitted copper pipes	DVGW-Arbeitsblatt GW 392
Permitted copper pipes	DIN EN 1057
Permitted stainless steel pipes	DVGW-Arbeitsblatt GW 541
Permitted stainless steel pipes	DIN EN 10312
Permitted stainless steel pipes	DIN EN 10088

Regulations from section: Corrosion

Scope / Notice	Regulations applicable in Germany
External corrosion protection	DIN EN 806-2
External corrosion protection	DIN 1988-200
External corrosion protection	DKI-Informationsdruck i. 160

Regulations from section: Installation position and settings

Scope / Notice	Regulations applicable in Germany
Dimensioning of circulation systems	DVGW-Arbeitsblatt W 553

Regulations from section: Leakage test

Scope / Notice	Regulations applicable in Germany
Leakage test for potable water installations	DIN EN 806, part 4
Leakage test for potable water installations	ZVSHK-Merkblatt „Dichtheitsprüfungen von Trinkwasserinstallationen mit Druckluft, Inertgas oder Wasser“

Regulations from section: Maintenance

Scope / Notice	Regulations applicable in Germany
Operation and maintenance of potable water installations	DIN EN 806-5

2.2 Intended use



Coordinate the use of the model for areas of use and media other than those described with the Viega Service Center.

The functionality of the valve is only ensured by professional design and assembly of the complete system.

2.2.1 Areas of use

Use is possible in the following areas among others:

- Hot water circulation pipelines
- Internally and parallel laid circulation pipes

The general rules of engineering and the applicable regulations must be observed for planning, execution, operation and maintenance of potable water installations, see ↪ *'Regulations from section: Fields of application'* on page 5.

2.2.2 Media

The model is also suitable for the following media, amongst others:

- Potable water without limitations acc. to the applicable directives, see ↪ *'Regulations from section: Media'* on page 6
- maximum chloride concentration 250 mg/l pursuant to applicable regulations, see ↪ *'Regulations from section: Media'* on page 6

2.3 Product description

According to the applicable regulations, Easytop system fittings can be used for all types of potable water and are DVGW certified, see [☞ 'Regulations from section: Product description' on page 6](#). Their plastic components comply with the KTW recommendation and the requirements pursuant to the applicable regulations.

2.3.1 Overview

The model is equipped as follows:

- valve casing made of silicon bronze
- dual-sided press connection with SC-Contur
- drain plugs for drainage valve G ¼
- regulating unit with valve cone and flexible material element
- temperature scale for setting temperature between 40 °C and 65 °C
- integrated ball valve
- converter flow regulator

The model can be shut off using the integrated ball valve.

The model is available in the following dimensions:

d	15	18	22
DN	15	15	20

2.3.2 Press connection with SC-Contur

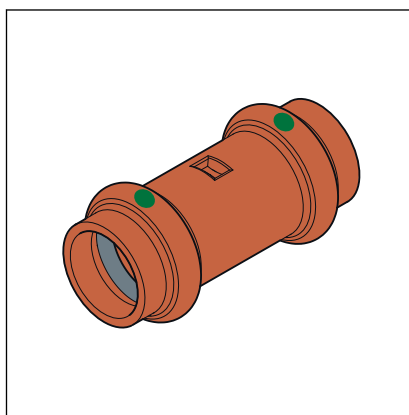

Fig. 1: Press connection using a press connector as an example

The press connection has a circumferential bead in which the sealing element lies. The connector is deformed upstream and downstream of the bead and permanently connected to the pipe during pressing. The sealing element is not deformed during pressing.

SC-Contur

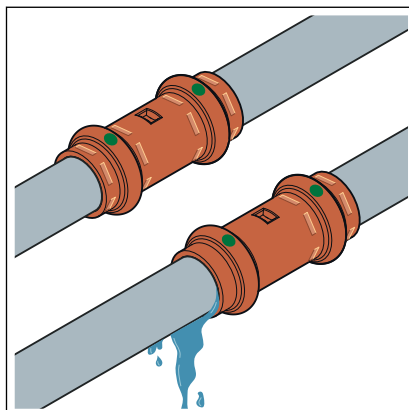

Fig. 2: SC-Contur

Viega press connectors are equipped with the SC-Contur. The SC-Contur is a safety technology that is certified by the DVGW and ensures that the connection is guaranteed to be leaky in an unpressed state. In this way, unpressed connections are noticed immediately during a leakage test.

Viega guarantees that unpressed connections are visible during a leakage test:

- with wet leakage test in the pressure range from 0.1 hPa–0.65 MPa (1.0 mbar–6.5 bar)
- with dry leakage test in the pressure range from 22 hPa–0.3 MPa (22 mbar–3.0 bar)

2.3.3 Sealing elements



NOTICE!

Only EPDM sealing elements are approved in potable water installations. The use of other sealing elements is not permitted.

The model is factory-fitted with EPDM sealing elements.

Area of use	Potable water
Operating temperature [$T_{max.}$]	80 °C
Operating pressure [$P_{max.}$]	1.0 MPa (10 bar)
Comments	see notes ↗ Chapter 2.2.2 'Media' on page 7

2.3.4 Markings on components

The model is marked as follows:

- flow direction indicator
- Dimension
- DVGW writing
- position indicator for operating mode
- green dot for potable water

2.3.5 Compatible components

The model is equipped with press connections and compatible with the Profipress, Sanpress and Sanpress Inox system.

Pipes

The press connections are tested and approved according to the applicable regulations with the following pipe types:

- Copper pipes
 - see ↗ *'Regulations from section: Compatible components' on page 6*
- Stainless steel pipes (material 1.4401 / 1.4521)
 - see ↗ *'Regulations from section: Compatible components' on page 6*

2.3.6 Operating mode

Circulation regulation valve (CRV)

The valve cone of the CRV is equipped with a flexible material element. The flexible material element reacts to changes in the temperature of the hot water in the circulation circuit.

Difference between target and actual value:	The CRV changes flowthrough volume and regulates the water temperature in this way.
Target value underrun:	Valve opens.
Target value exceeded:	Valve closes.
Target value and actual value match:	Hydraulic / thermal calibration is completed.

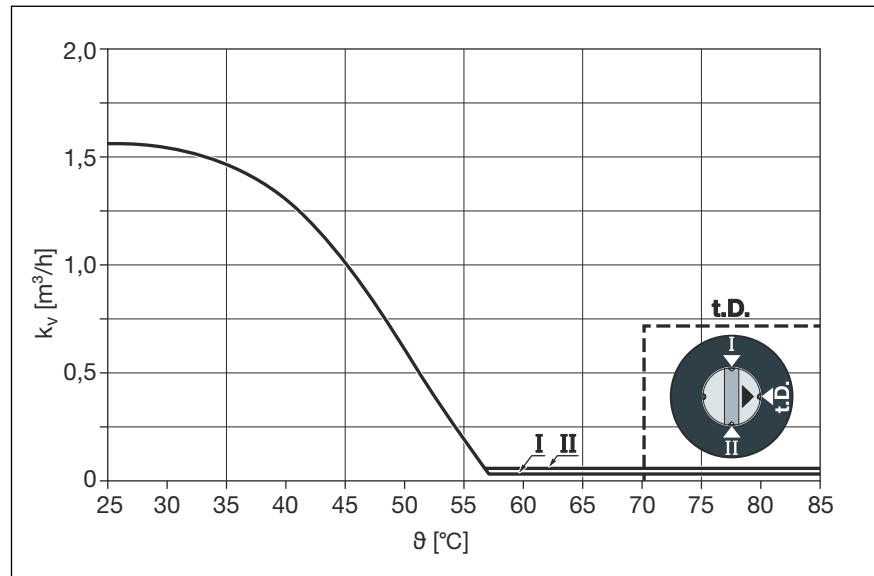

Fig. 3: Diagram minimum flowthrough / temperature

2.3.7 Technical data

Observe the following operating conditions for the installation of the model:

Operating temperature [T_{max}]	80 °C
Operating pressure [P_{max}]	1.0 MPa (10 bar)
Temperature range (settable)	40 °C up to 65 °C
Factory settings	57 °C

Pressure loss

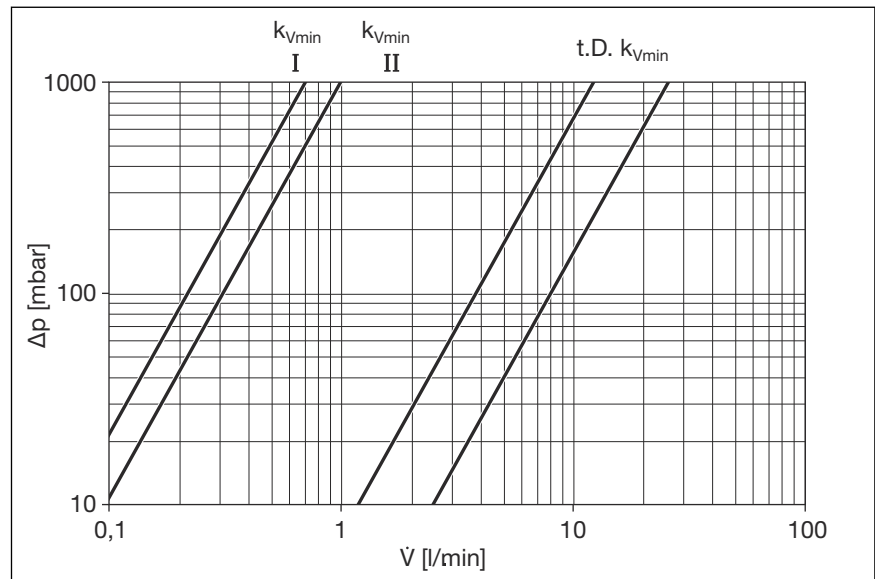

Fig. 4: Diagram operating modes / Pressure losses

Setting the flowthrough regulation

Switch position	Minimum flow-through in m ³ / h	Maximum flow-through in m ³ / h
I	on the storey: 0.042	on the storey: 1.542
II	in the riser pipe: 0.060	in the riser pipe: 1.560
t. D.		thermal disinfection at 70 °C: 0.72

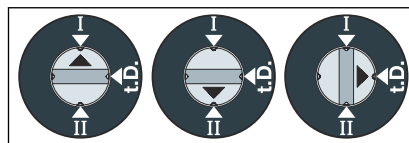

Fig. 5: CRV flowthrough regulation

The flowing values are valid for kV [Δp 1000 hPa (1000 mbar)]:

Temperature °C	65	60	57	55	50	45	40	Flowthrough m ³ /h switch I	Flowthrough m ³ /h switch II
65.0	65.0	60.0	57.5	55.0	50.0	45.0	40.0	0.042	0.060
60.0	60.0	57.5	55.0	52.5	47.5	42.5	37.5	0.258	0.276
57.5	57.5	55.0	52.5	50.0	45.0	40.0	35.0	0.407	0.425
55.0	55.0	52.5	50.0	47.5	42.5	37.5	32.5	0.618	0.636
52.5	52.5	50.0	47.5	45.0	40.0	35.0	30.0	0.803	0.521
50.0	50.0	47.5	45.0	42.5	37.5	32.5	27.5	1.056	1.074
47.5	47.5	45.0	42.5	40.0	35.0	30.0	25.0	1.178	1.196
45.0	45.0	42.5	40.0	37.5	32.5	27.5	22.5	1.296	1.314
42.5	42.5	40.0	37.5	35.0	30.0	25.0	20.0	1.325	1.400
40.0	40.0	37.5	35.0	32.5	27.5	22.5	-	1.497	1.497
37.5	37.5	35.0	32.5	30.0	25.0	20.0	-	1.488	1.506
35.0	35.0	32.5	30.0	27.5	22.5	-	-	1.506	1.524

2.4 Information for use

2.4.1 Corrosion

Overground pipelines and fittings in rooms do not normally require external corrosion protection.

There are exceptions in the following cases:

- Contact with aggressive building materials such as nitrite or materials containing ammonium
- in aggressive surroundings

If external corrosion protection is required, observe the pertinent guidelines, see ↗ *'Regulations from section: Corrosion' on page 6.*



Easytop fittings made of gunmetal/silicon bronze are suitable for all types of potable water.

The chloride concentration in the medium must not exceed a maximum value of 250 mg/l.

This chloride is not a disinfectant, but in fact pertains to the content in sea and table salt (sodium chloride).

2.5 Optional accessories

The following optional accessories are available:

- Actuator set
- Drainage valve
- Thermometer
- Insulating shell



Fig. 6: Model 1013.9 Easytop actuator set

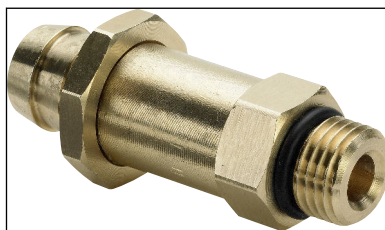

Fig. 7: Model 2278.8 Easytop drainage valve



Fig. 8: Model 1026.6 Easytop thermometer

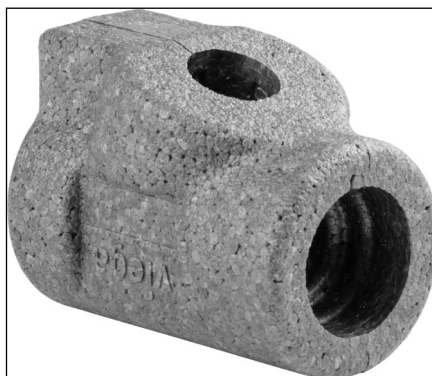

Fig. 9: Model 2210.50 Easytop insulating shell

An EPS insulating shell is available for the circulation regulation valve. The two-piece insulating shell is self-supporting and is mounted without tools and holding grips. They close seamlessly on the front surface of the pipeline insulation.

3 Handling

3.1 Assembly information

3.1.1 Permitted exchange of sealing elements



Important instruction

With their material-specific qualities, sealing elements in press connectors are adapted for use with the corresponding media and/or the areas of use of the piping systems and are generally only certified for them.

The exchange of a sealing element is generally permitted. The sealing element must be exchanged for a designated spare part for the intended application ↪ *Chapter 2.3.3 'Sealing elements' on page 9*. The use of other sealing elements is not permitted.

3.1.2 Mounting instructions

Checking system components



Do not remove the model from the packaging until immediately before use.

System components may, in some cases, become damaged through transportation and storage.

- Check all parts.
- Replace damaged components.
- Do not repair damaged components.
- Contaminated components may not be installed.

During assembly

Observe the following when mounting:

- use suitable tools
- flow direction indicator
- When tightening the connection screw fitting, counter by holding the key surface of the valve.



Choose the place of installation so that the fitting is easy to access and operate and the insulating shell and if applicable the Easytop actuator set can be mounted without any problems.

Laying and fixing pipes

For information, refer to the instructions for use of the Profipress, Sanpress and Sanpress Inox systems.

Length expansion

For information, refer to the instructions for use of the Profipress, Sanpress and Sanpress Inox systems.

3.1.3 Required tools

Press connection

The following tools are required for production of a press connection:

- pipe cutter or a fine-toothed hacksaw
- deburrer and coloured pen for marking
- press machine with constant pressing force
- Press jaw or press ring with corresponding hinged adapter jaw, suitable for the pipe diameter and suitable profile

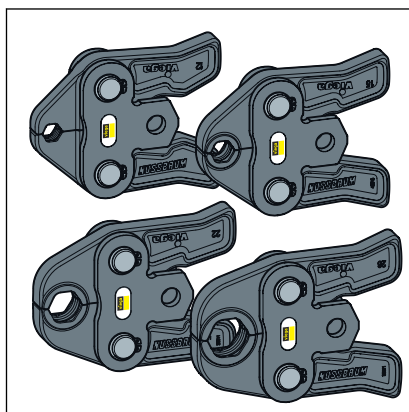

Fig. 10: Press jaws

Recommended Viega press machines:

- Pressgun 5
- Pressgun 4E / 4B
- Type PT3-AH
- Type PT3-H / EH
- Type 2 (PT2)
- Pressgun Picco
- Picco

Temperature setting

An Allen key (size 6) is required to set the temperature.

Removal drain plugs

An Allen key (size 5) is required to remove the drain plug.

3.2 Assembly

3.2.1 Replacing the sealing element

Removing the sealing element



Do not use pointed or sharp-edged objects to remove the sealing element. They may damage the sealing element or the bead.

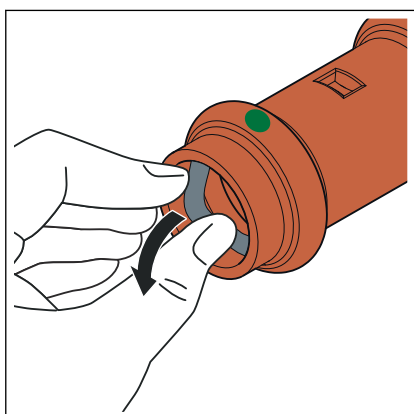

- Remove the sealing element from the bead.

Inserting the sealing element

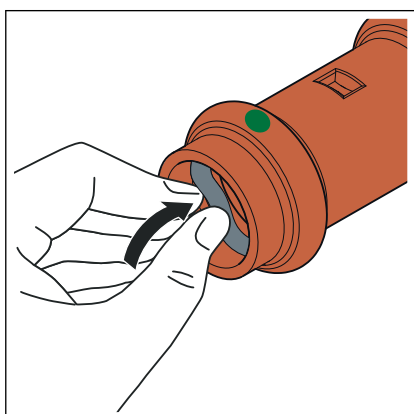

- Insert a new, undamaged sealing element into the bead.
- Ensure that the complete sealing element is in the bead.

3.2.2 Shortening the pipes



NOTICE! Leaky press connections due to damaged material!

Press connections can become leaky due to damaged pipes or sealing elements.

Observe the following instructions to avoid damage to pipes and sealing elements:

- Do not use cutting discs (angle grinders) or flame cutters when cutting to length.
- Do not use grease or oils (e. g. cutting oil).

For information about tools, also see [Chapter 3.1.3 'Required tools'](#) on page 17.

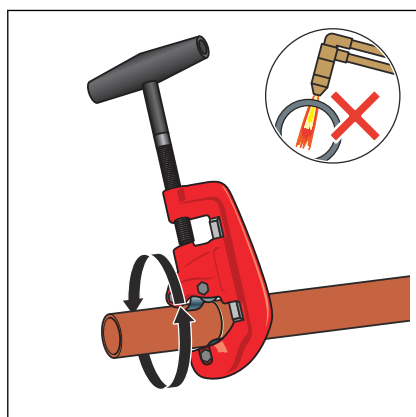

- Cut the pipe properly using a pipe cutter or fine-toothed hacksaw. Avoid grooves on the pipe surface.

3.2.3 Pressing the connection



NOTICE! Leaky press connections due to pipes being too short

If two press connectors are to be mounted onto a pipe without an interval, the pipe must not be too short. If the pipe is not inserted up to the prescribed insertion depth in the press connector during pressing, the connection may become leaky.

In the case of pipes with a diameter of d 15–28 mm, the pipe must be at least as long as the total insertion depth of both press connectors.

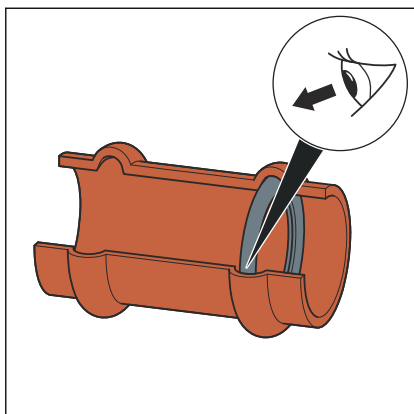
Requirements:

- The pipe end is not bent or damaged.
- The pipe is deburred.
- The correct sealing element is in the press connector.
EPDM = polished black
- The sealing element is undamaged.
- The complete sealing element is in the bead.

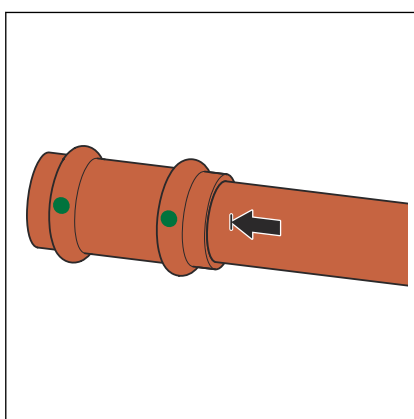

- Push the press connector onto the pipe as far as it will go.

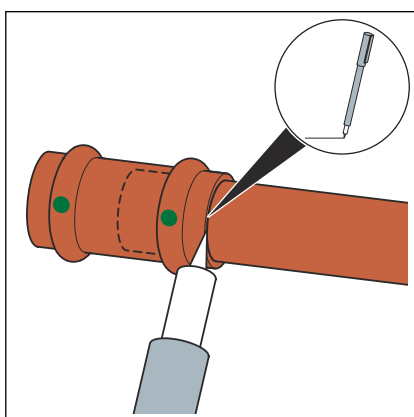

- Mark the insertion depth.
- Place the press jaw onto the press machine and push the retaining bolt in until it clicks into place.

INFO! Observe the press tool instruction manual.

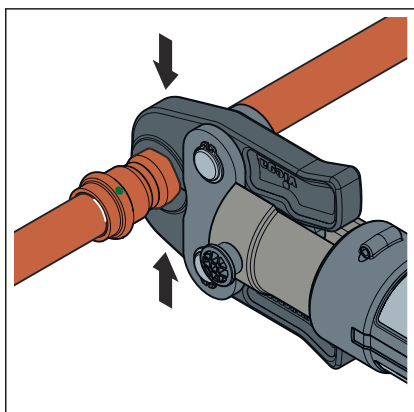

- Open the press jaw and place it at a right-angle onto the press connector.
- Check the insertion depth using the marking.
- Ensure that the press jaw is placed centrally on the bead of the press connector.

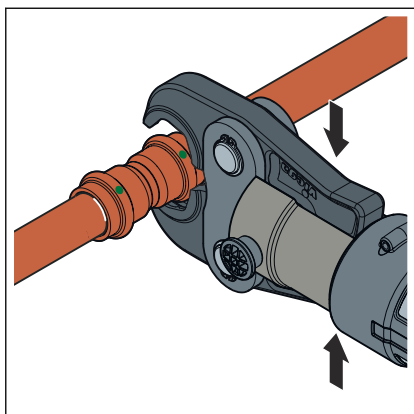

- Carry out the pressing process.
- Open and remove the press jaw.
- ◻ Connection is pressed.

3.2.4 Installation position and settings

Installation position

Installation is possible in both the riser pipe and on the storey.

If there are multiple riser pipes on the storey during the installation of the circulation regulation valve, then every riser pipe must have a circulation regulation valve mounted, see  Fig. 12.



NOTICE!

According to the applicable directives, circulation regulation valves must be installed between the outlet of the hot water tank and the circulation inlet, see  'Regulations from section: Installation position and settings' on page 6.

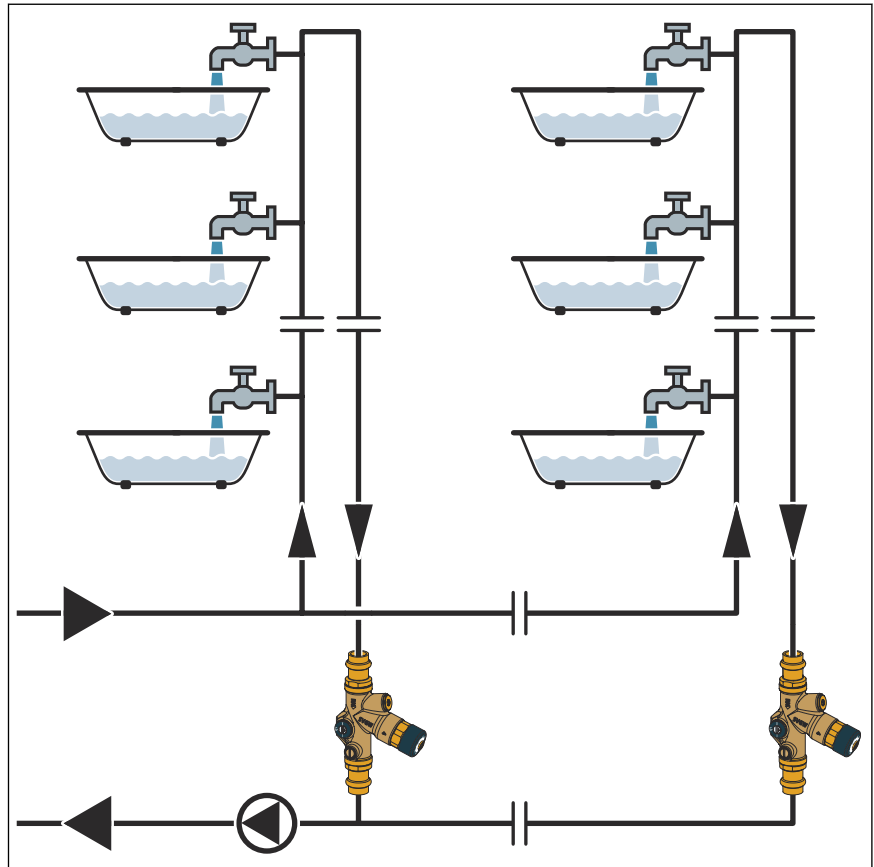

Fig. 11: CRV in the riser pipe

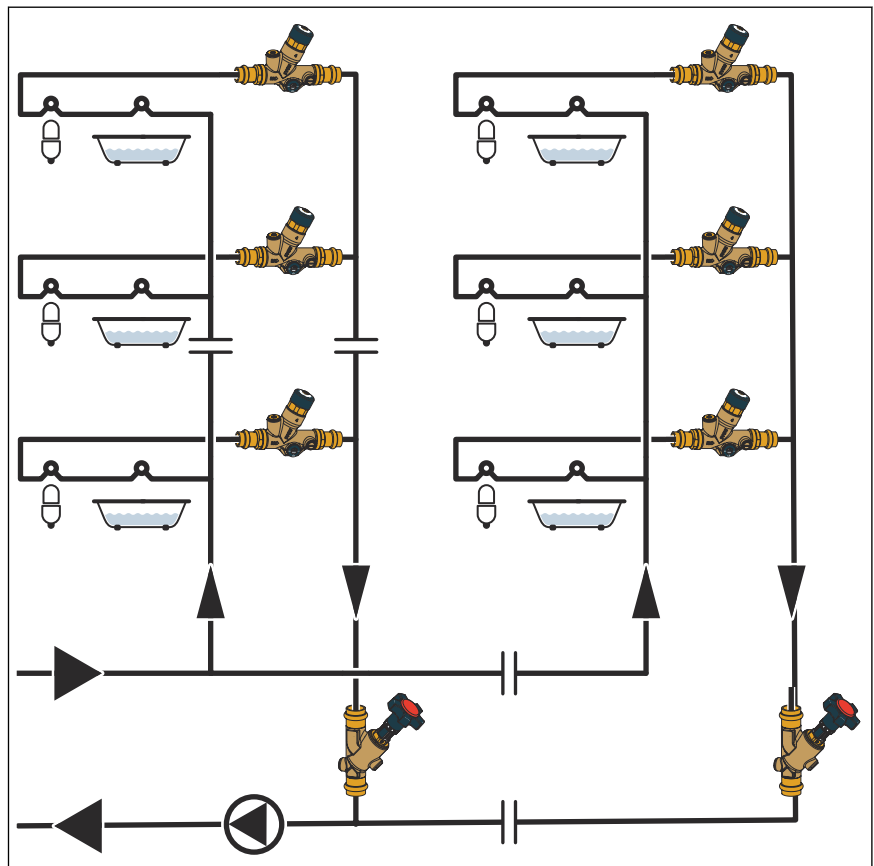

Fig. 12: CRV on the storey

Settings

- Set the temperature and flow regulation before commissioning.
- Use in the section: Bring flowthrough control to position II.
- Use on the storey: Bring flowthrough control to position I.
- For thermal disinfection: Bring flowthrough control to position **t.D.**.
- Temperature setting: Set to calculated target value.

Temperature setting

An Allen key (size 6) is required to set the temperature.

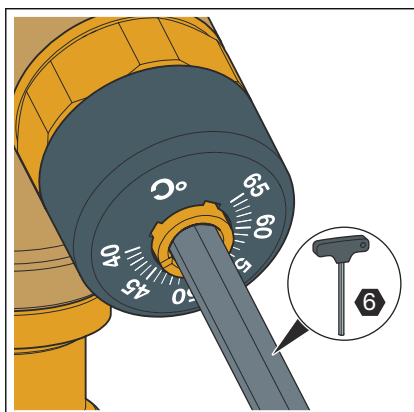
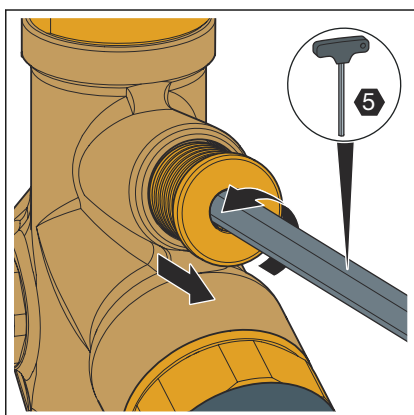

Fig. 13: CRV set temperature

- Set the temperature at the temperature control valve with Allen key (size 6).

3.2.5 Mounting the Easytop drainage valve and Easytop thermometer



- Unscrew the drain plugs with an Allen key (size 5).

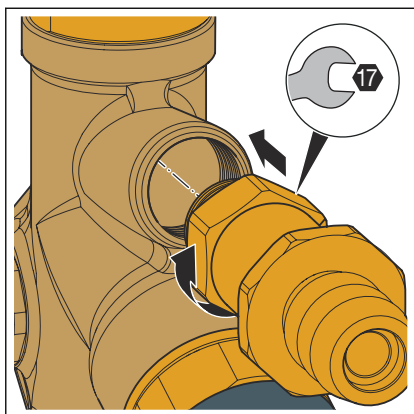

- Insert the Easytop drainage valve and tighten using a fork spanner (size 17). Sealing is achieved using an O-Ring.

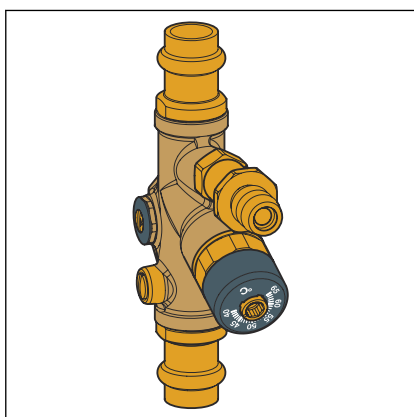

The Easytop drainage valve has the following functions:

- Draining
- Seat sensor actuator set
- Seat Easytop thermometer

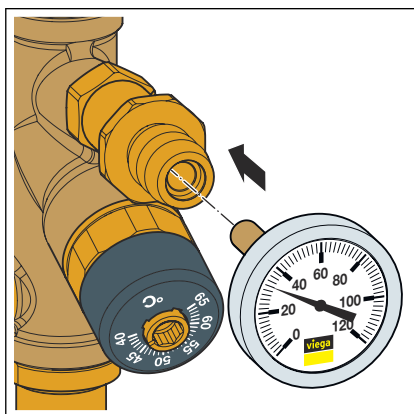

- Insert the Easytop thermometer into the closed Easytop drainage valve.

3.2.6 Thermal disinfection



CAUTION!

Risk of scalding from hot water!

Inform users and secure the draw-off point before beginning the flushing process.

Mode of operation

Contaminated potable water installations can be disinfected by short-term flushing with hot water with a temperature of 70 °C. Thermal disinfection is achieved by flushing all parts that come into contact with water with hot water with a temperature of 70 °C for at least 3 minutes.

To avoid injury due to hot water, the process must be discussed with the system's users.

Procedure

In units with more than one system, the circuits are disinfected individually one after another. Proceed as follows:

- Heat the hot water temperature to at least 70 °C.
- Close the ball valves on the Easytop circulation regulation valves of the lines not in use.
- Place the converter for the flowthrough regulator on the Easytop circulation regulation valve to position **t.D.**
- Open every extraction fitting fully and flush for at least 3 minutes after 70 °C has been reached.
- Place the flowthrough regulator and ball valve in the operating position.
- Do exactly the same with all of the circulation circuits.



NOTICE!

Thermal disinfection can be carried out automatically in combination with a building management system (on-site) and the Easytop actuator set model 1013.9. Manual adjustment of the valve is no longer necessary.

3.2.7 Leakage test

The installer must perform a leakage test before commissioning.

Carry out this test on a system that is finished but not covered yet.

Comply with the general rules of engineering and the applicable directives, see  'Regulations from section: Leakage test' on page 7.

Document the result.

3.3 Maintenance



NOTICE!

Inform your customer or the operator of the potable water installation that the system has to be maintained on a regular basis.

Observe the applicable regulations for the operation and maintenance of potable water installations, see  'Regulations from section: Maintenance' on page 7.

3.4 Disposal

Separate the product and packaging materials (e. g. paper, metal, plastic or non-ferrous metals) and dispose of in accordance with valid national legal requirements.



Viega GmbH & Co. KG
service-technik@viega.de
viega.com

INT • 2022-08 • VPN190453

