

Instructions for Use

Advantix Top floor drain

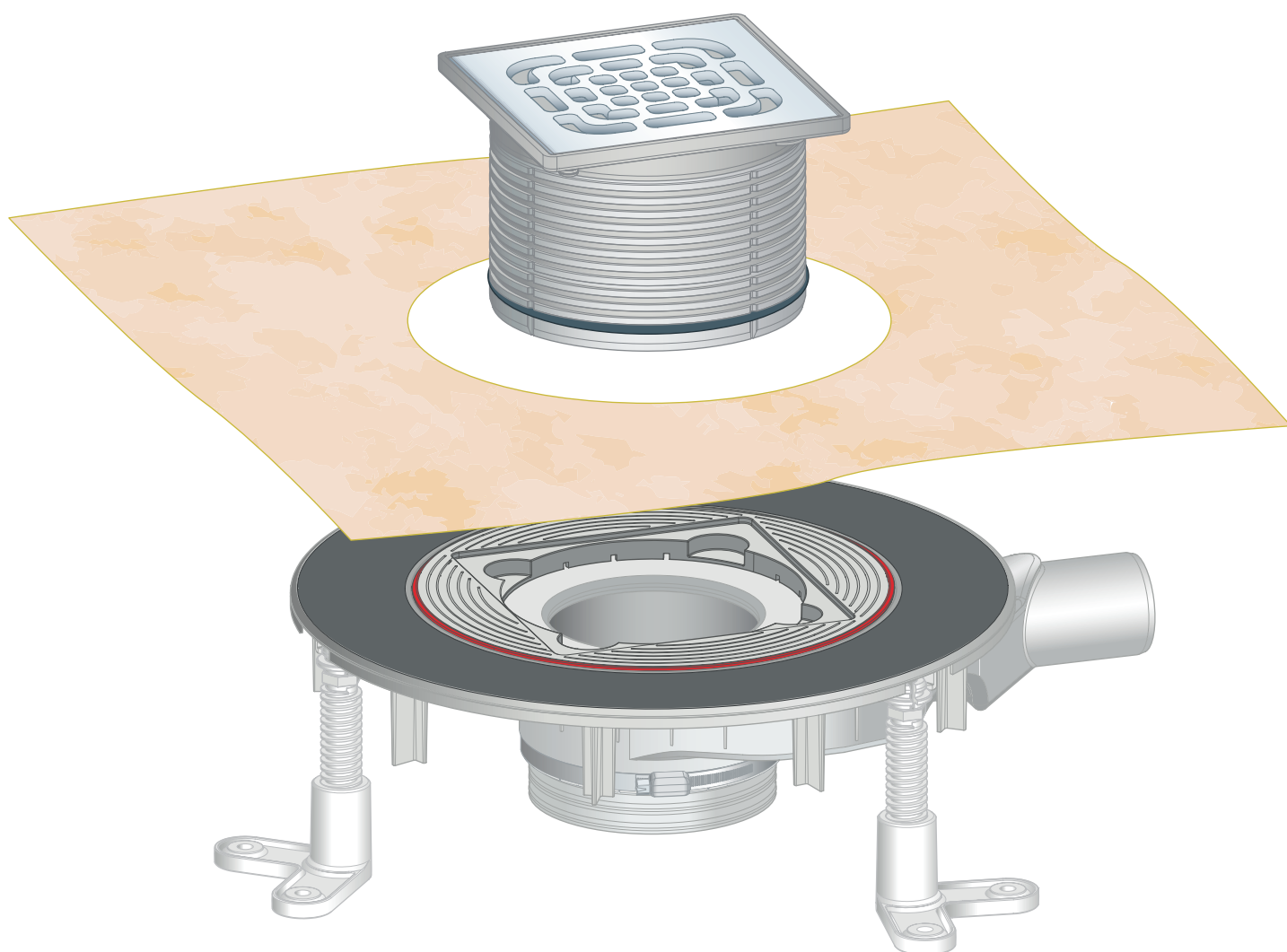

for bonded sealing (tiled shower) with sealing mat

Model
4914.21

Year built (from)
01/2010

viega

Table of contents

1	About these instructions for use	3
	1.1 Target groups	3
	1.2 Labelling of notes	3
	1.3 About this translated version	4
2	Product information	5
	2.1 Standards and regulations	5
	2.2 Certification	5
	2.3 Intended use	6
	2.3.1 Areas of application	6
	2.3.2 Media	6
	2.3.3 Drainage capacity	7
	2.4 Product description	7
	2.4.1 Overview	7
	2.4.2 Technical data	8
	2.5 Information for use	8
	2.5.1 Installation variations	8
	2.5.2 Sealing	9
	2.5.3 Fire protection	11
	2.6 Required accessories	12
3	Handling	13
	3.1 Assembly information	13
	3.1.1 Important note	13
	3.1.2 Installation dimensions	14
	3.1.3 Tools and materials	14
	3.2 Assembly	15
	3.2.1 Construction and water seal level	15
	3.2.2 Mounting base unit	17
	3.2.3 Sealing the drain	19
	3.2.4 Mounting the top	22
	3.2.5 Consider screed thickness	23
	3.3 Care	27
	3.3.1 Care tips	27
	3.3.2 Cleaning the drain	27
	3.4 Disposal	28

1 About these instructions for use

Trade mark rights exist for this document; for further information, go to viega.com/legal.

1.1 Target groups

The information in this instruction manual is directed at the following groups of people:

- Heating and plumbing experts and trained personnel
- Tilers
- Consumers

Individuals without the abovementioned training or qualification are not permitted to mount, install and, if required, maintain this product. This restriction does not extend to possible operating instructions.

The installation of Viega products must take place in accordance with the general rules of engineering and the Viega instructions for use.

1.2 Labelling of notes

Warning and advisory texts are set aside from the remainder of the text and are labelled with the relevant pictographs.



DANGER!

This symbol warns of possible life-threatening injury.



WARNING!

This symbol warns of possible serious injury.



CAUTION!

This symbol warns of possible injury.



NOTICE!

This symbol warns of possible damage to property.



This symbol gives additional information and hints.

1.3 About this translated version

This instruction for use contains important information about the choice of product or system, assembly and commissioning as well as intended use and, if required, maintenance measures. The information about the products, their properties and application technology are based on the current standards in Europe (e.g. EN) and/or in Germany (e.g. DIN/DVGW).

Some passages in the text may refer to technical codes in Europe/Germany. These should serve as recommendations in the absence of corresponding national regulations. The relevant national laws, standards, regulations, directives and other technical provisions take priority over the German/European directives specified in this manual: The information herein is not binding for other countries and regions; as said above, they should be understood as a recommendation.

2 Product information

2.1 Standards and regulations

The following standards and regulations apply to Germany / Europe and are provided as a support feature.

Regulations from section: Sealing

Scope / Notice	Regulations applicable in Germany
Stress class of the underground, as well as suitable bonded sealing	Leitfaden zur Abdichtung im Verbund (AIV)
Approved bonded sealings with proof of practicability in keeping with building law for stress classes A and AO	ETAG 022 T1
Approved bonded sealings with proof of practicability in keeping with building law for stress classes A, B and C	DIBt-Bauregelliste A, Teil 2 des DIBt und Prüfgrundsätze für Abdichtungen im Verbund (PG AIV-F)
Permitted bonded sealings	EN 14891
Sealing of inside rooms	DIN18534

Regulations from section: Media

Scope / Notice	Regulations applicable in Germany
Typical domestic wastewater	DIN 1986-3

2.2 Certification

Data acc. to DIN EN 1253-6, Table 10

Data acc. to DIN EN 1253-1, Table 7

Manufacturer	Viega GmbH & Co.KG
Manufacturer identification mark	

Certificate of conformity	
Address	Viega GmbH & Co.KG Viega Platz 1 57439 Attendorn Germany
Relevant standard	DIN EN 1253-1 DIN EN 1253-6
DN	50
Product class with respect to temperature behaviour	A
Drainage capacity at accumulation height 10 mm	0.85 - 1.15 l/s
Drainage capacity at accumulation height 20 mm	0.9 - 1.2 l/s
Load-bearing capacity class	K

2.3 Intended use

2.3.1 Areas of application

The drain is dimensioned for small to medium volumes of water, which occur in e.g. residential buildings.

Technical information, see [↪ Chapter 2.4.2 'Technical data' on page 8.](#)

2.3.2 Media

- The short-term temperature of the wastewater may reach up to 95° C. The temperature must be considerably lower in constant operation.
- The pH value must be higher than four but lower than ten.

It is not permitted to introduce wastewater, which could damage the product material.

2.3.3 Drainage capacity

The drainage capacity is dependent on the chosen installation height.

The drainage capacity is 0.75 l/s up to 1.2 l/s with horizontal DN 50 drain socket.

The drainage capacity is 0.85 l/s up to 0.9 l/s with horizontal DN 50 drain socket.

2.4 Product description

2.4.1 Overview

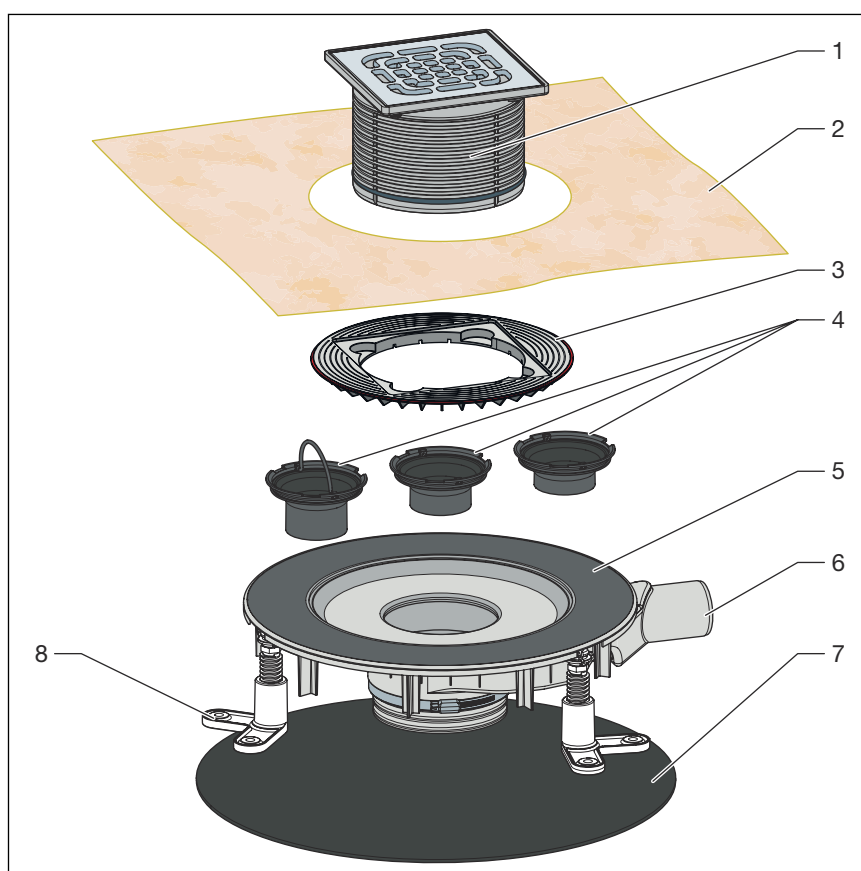

Fig. 1: Scope of delivery model 4914.21

- 1 top with grate, can be cut to length
- 2 Sealing collar
- 3 insert ring for top
- 4 Immersion pipe
- 5 flange for the application of the bonded sealing
- 6 Base unit
- 7 sound protection mat
- 8 Adjustable feet

2.4.2 Technical data

Nominal width [DN] (drain socket)	50
Drainage capacity	↪ Chapter 2.3.3 'Drainage capacity' on page 7
Dimensions and installation height	↪ Chapter 3.1.2 'Installation dimensions' on page 14
Water seal level	30 up to 50 mm
Load class	K = 300 kg

2.5 Information for use

2.5.1 Installation variations

Installing in a bare concrete floor

The mounting of the drain in a bare concrete floor is as follows:

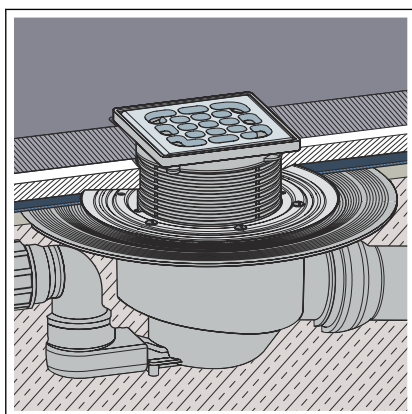

Fig. 2: General installation example – Floor recess

- The drain is placed in a floor recess and then cast-in.

Mounting on a floor

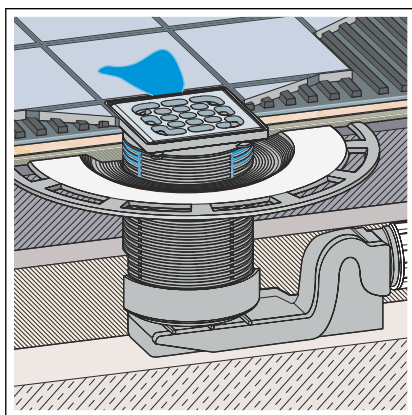

Fig. 3: General mounting example – Mounting on the floor

During the mounting on the floor, the drain is integrated into the floor construction. At the same time, the drain can e.g. be integrated into the levelling screed or heat insulation. If necessary, a vertical drainpipe can be led through a drill hole in the floor at the same time.



NOTICE!

The creation of a floor recess must be agreed with the following people:

- a structural engineer
- the on-site fire protection inspector or the specialist engineer for fire protection

If necessary, proof of compliance with building code or an expert's report must exist.

2.5.2 Sealing

Bonded sealing

To protect against moisture penetration, apply sealing foils, which are to be processed in liquid state, directly below the tiles on screed and walls. The determination of the stress class and the underground as well as the selection of the suitable bonded sealing must be carried out in compliance with the valid standards and regulations, see: ↗ *Chapter 2.1 'Standards and regulations' on page 5.*

The bonded seal can be applied directly onto the drain flange.

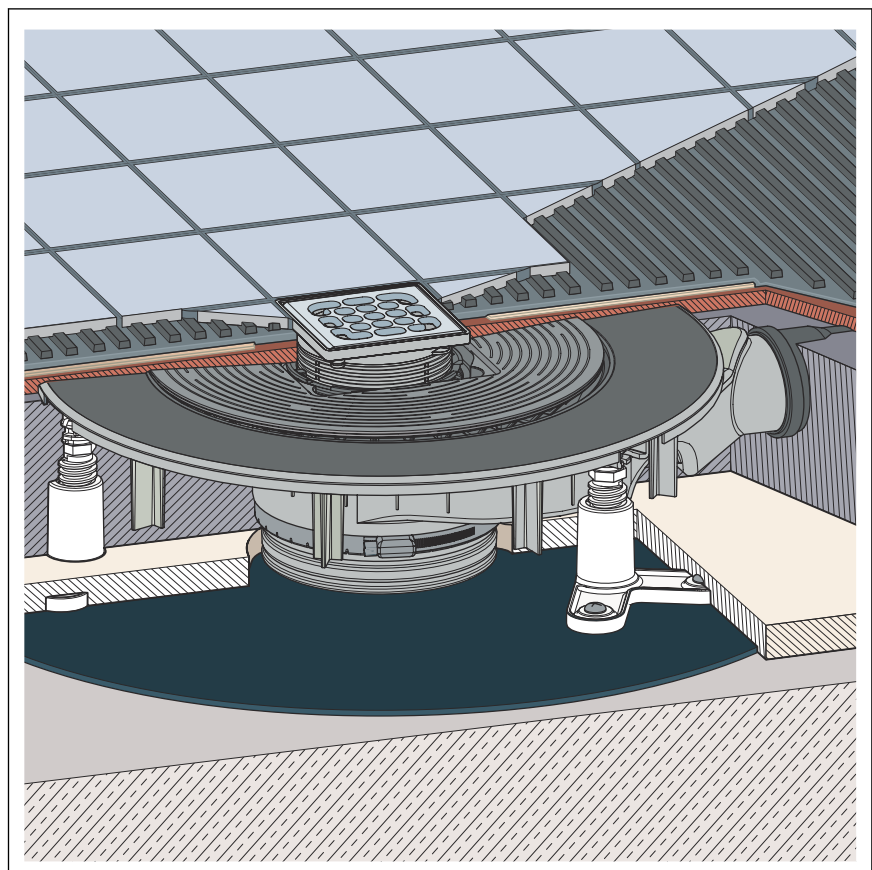

Fig. 4: Diagram of a bonded seal

Important note

Careful planning is required for sealing. In addition, depending on the individual dampness wear class and the type of foundation, a suitable thin bed bonded sealing with a building regulations certificate of suitability must be chosen.

Furthermore, the following factors should be taken into account:

- The drain or shower channel must be equipped with a special flange, which has an adhesive surface and a width of at least 50 mm.
- For bridging the material change from drain to screed, either a suitable sealing collar or sealing tape designed for overlapping with the thin bed bonded sealing over a width of at least 50 mm must be used.
- The screed must be laid at a minimum incline of 1–2%.
- The installation must be carried out in acc. with the mounting instructions and the manufacturer's information.

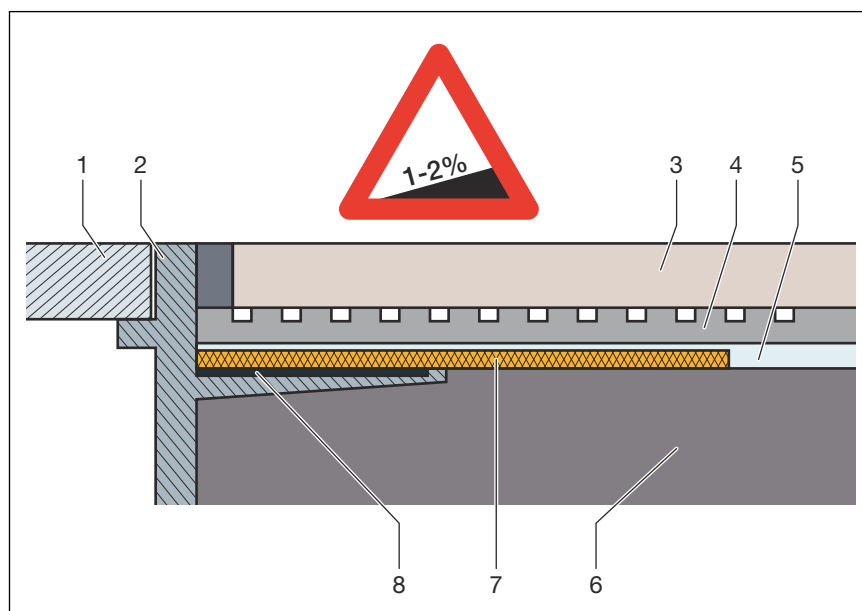

Fig. 5: Construction diagram of the bonded seal - min. screed incline 1–2 %

- 1 Grate
- 2 Top piece with adhesive flange
- 3 Tile
- 4 Tile cement
- 5 Bonded sealing
- 6 Screed
- 7 Sealing collar
- 8 Adhesive

Permitted bonded seals

In connection with suitable drains, only approved bonded sealings with proof of practicability in keeping with building law may be used. See [Chapter 2.1 'Standards and regulations'](#) on page 5.

Information regarding the procedure can be found in the instructions for use of the corresponding product.

2.5.3 Fire protection

Advantix shower channels and drains can both be fitted to be fire proof. The R120 pipe lead-in can be used for this purpose in the floor construction. In this way, a fire resistance time of up to 120 minutes can be achieved.

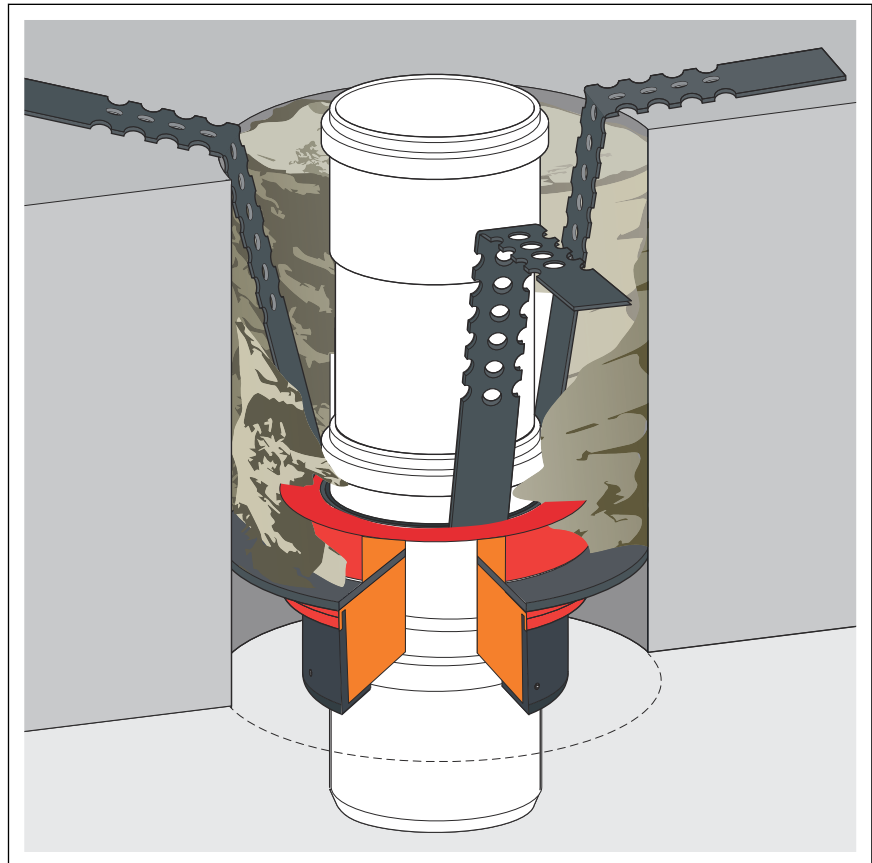
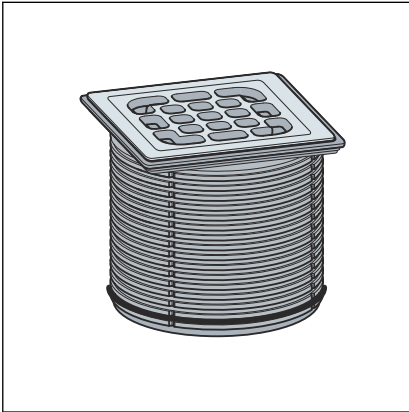

Fig. 6: Example: fire protection pipe lead-in

For mounting instructions for the R120 pipe lead-in see model 4923.5, art. no. 491 673.

2.6 Required accessories

Top



Advantix tops are available in a number of sizes and variations. You can also only buy an Advantix top frame and then purchase a suitable designer grate separately (see catalogue).

Sieve insert

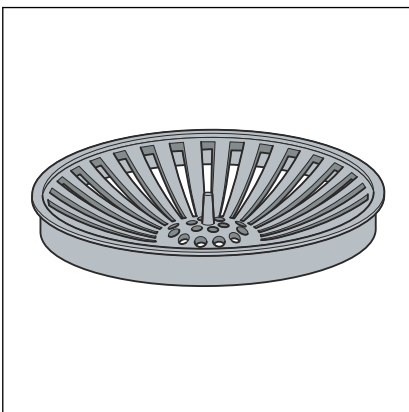

The drain can be fitted with a sieve insert (model 4923.1) to collect dirt.

3 Handling

3.1 Assembly information

3.1.1 Important note

Before assembly:

- Check if the drainage capacity of the drain is sufficient for the arising water volume ↪ *Chapter 2.3.3 'Drainage capacity' on page 7.*
- Check if the installation height of the drain corresponds with the planned floor construction.
- Ensure that the required connection line is installed with the necessary incline to the planned installation location.
- If necessary, supply the required accessories ↪ *Chapter 2.6 'Required accessories' on page 12.*

During assembly:

- Observe installation dimensions.

After assembly:

- The drain flange must be fully lined with mortar.

3.1.2 Installation dimensions

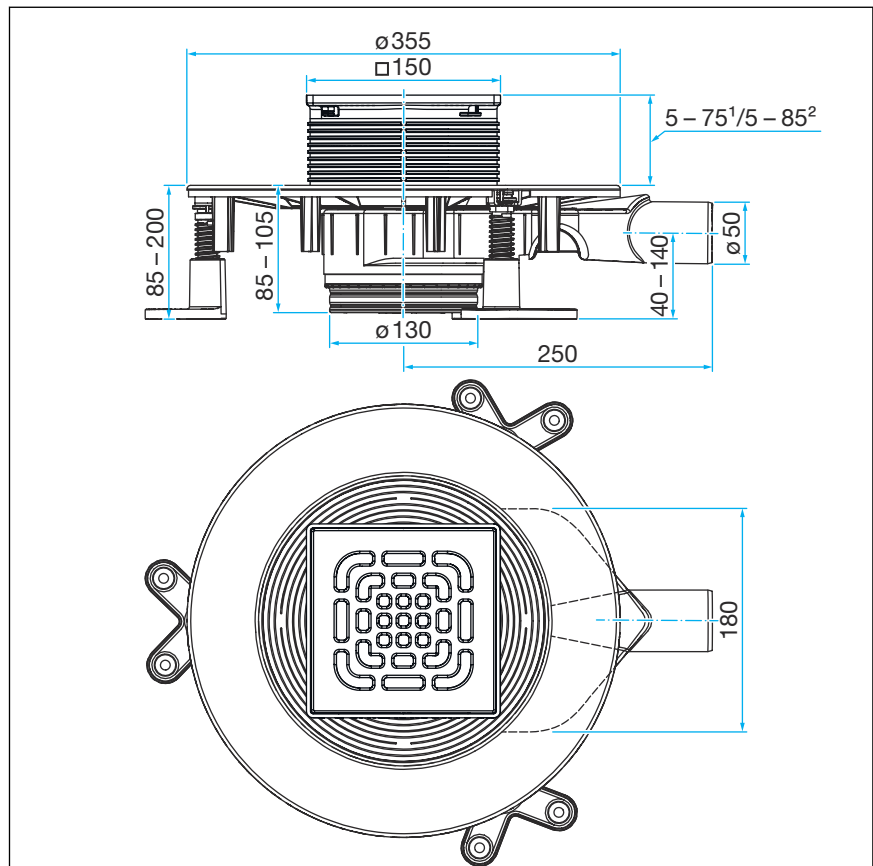

Fig. 7: Dimensional drawing model 4914.21

- 1 Top frame made of plastic
- 2 Top frame made of stainless steel

3.1.3 Tools and materials

Required material

- Top with grate, if not included in scope of delivery
- Material for securing the drain

3.2 Assembly

3.2.1 Construction and water seal level

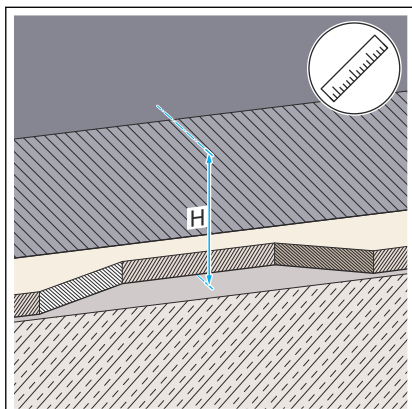

- Determine the installation height.



At a desired installation height of ≥ 105 mm upper edge sealing flange the floor piece remains in the delivery condition.

The water seal level is 50 mm and the immersion pipe length 48 mm.

Installation height 96–105 mm

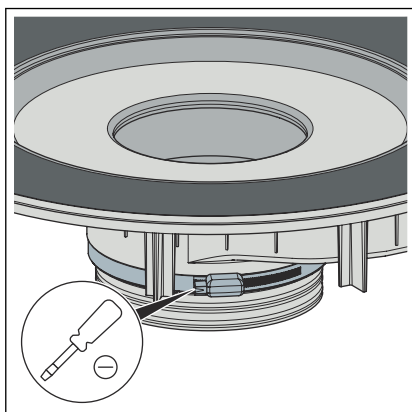

- Loosen the clamping ring with a screwdriver.

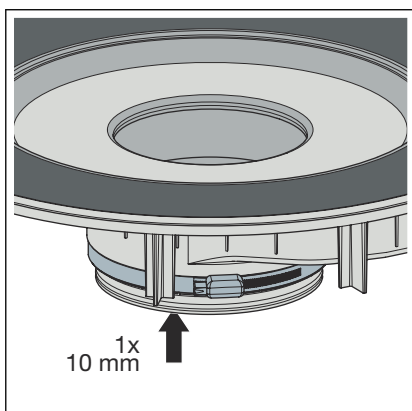

- Remove the clamping ring and push the floor piece in by one ring (1 x 10 mm).

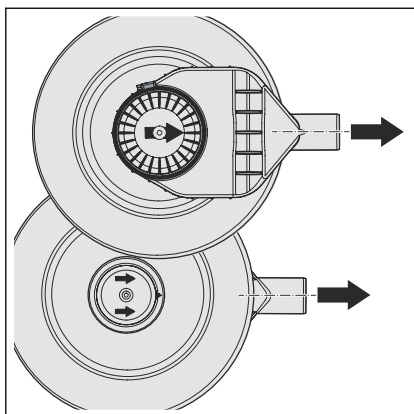

- Align the floor piece in such a way that the arrows point towards the drainpipe.

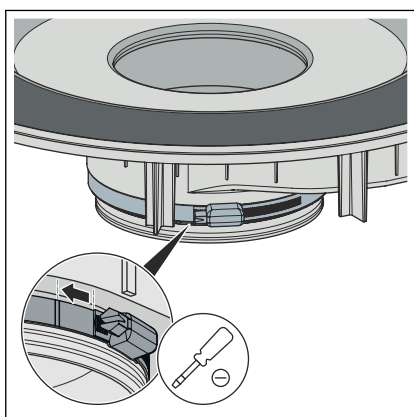

- Secure the floor piece with the clamping ring.

Tighten the screw of the clamping ring with max. 2.5 Nm \pm 0.2 Nm. Alternatively, tighten the end of the clamping ring up to or between the markings.

- The water seal level is 40 mm and the immersion pipe length 38 mm.

Installation height 85–95 mm

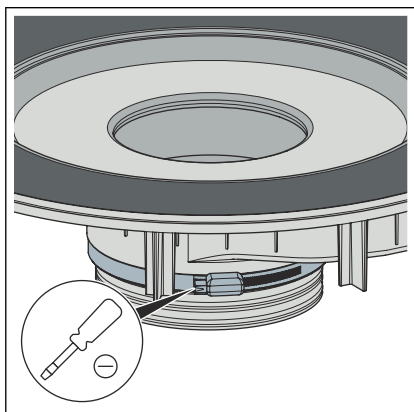

- Loosen the clamping ring with a screwdriver.

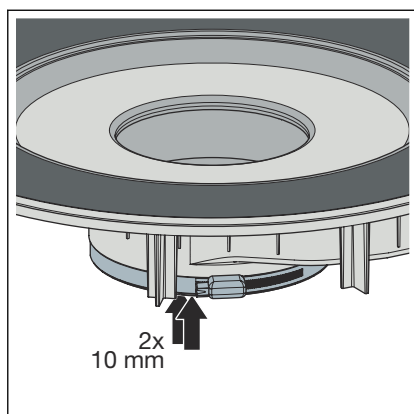

- Remove the clamping ring and push the floor piece in by two rings (2 x 10 mm).

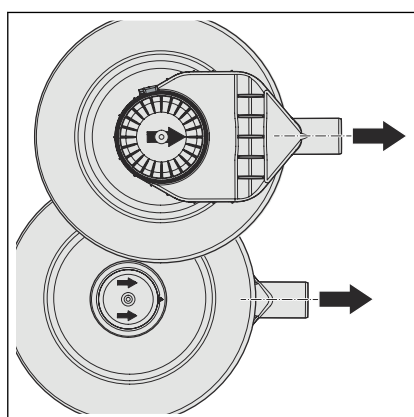

- Align the floor piece in such a way that the arrows point towards the drainpipe.

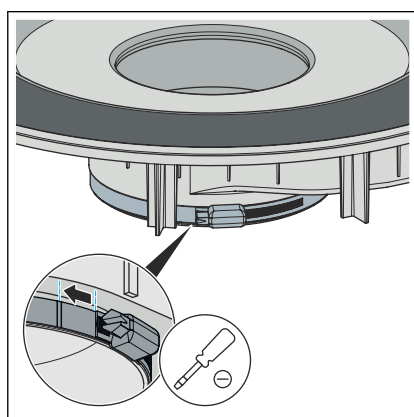

- Secure the floor piece with the clamping ring.
Tighten the screw of the clamping ring with max. 2.5 Nm \pm 0.2 Nm. Alternatively, tighten the end of the clamping ring up to or between the markings.
- The water seal level is 35 mm and the immersion pipe length 33 mm.

3.2.2 Mounting base unit

A few points must be observed to integrate the drain into the floor construction properly. For this reason, proceed as follows to prepare the drain for subsequent work:

Requirements

- A pipe to the planned drainage position is already in place for the connection to the wastewater system.
- The drainpipe has an internal sealing lip.
- Insert the drain socket into the drainpipe as far as it will go.

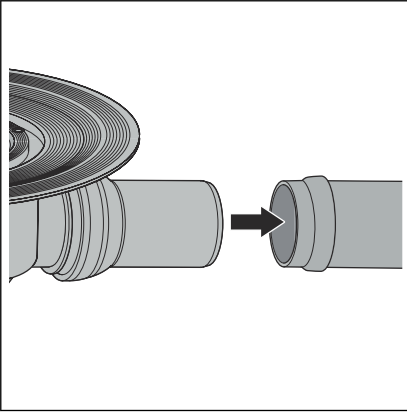

- Position the bathroom drain with sound protection mat on the raw concrete floor.

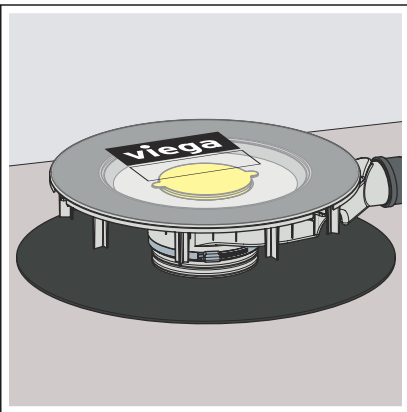

- If necessary, shorten the adjusting feet to the correct dimension at one of the two interfaces provided and mount them.

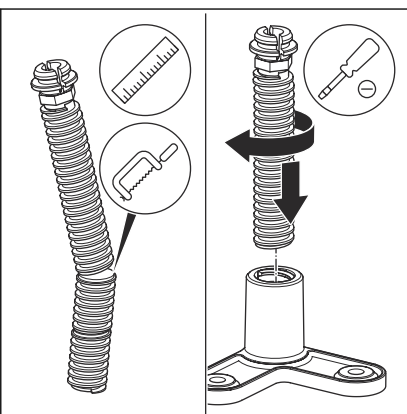

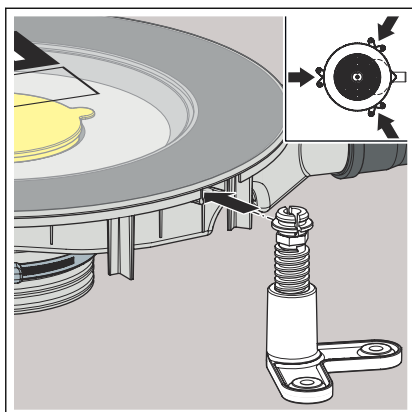

- Place the adjusting feet into the retaining brackets.

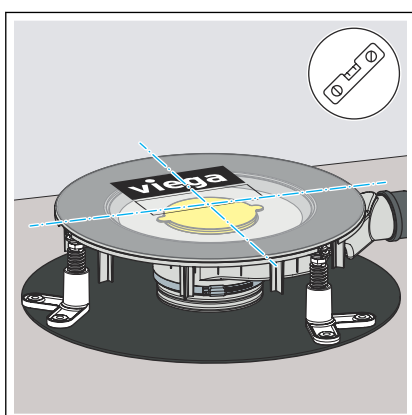

- Align the bath drain horizontally with the adjusting feet.

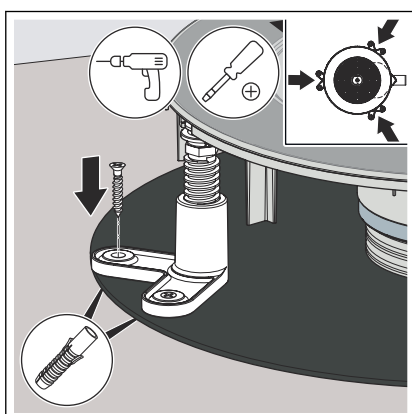

- Secure the adjusting feet with the supplied dowels and screws.
 - The bathroom drain can be integrated into the floor construction.



NOTICE!
Product damage due to improper installation

If hollow spaces occur during the lining of the drain, leaks may occur when pressure is applied.

Inform the subsequent workers that the drain must be fully lined and that there must be no hollow spaces.

3.2.3 Sealing the drain



NOTICE!
Product damage due to improper installation

If hollow spaces occur during the lining of the drain, leaks may occur when pressure is applied.

Check the completion of the subsequent work.



The screed and floor tiles must be laid at an incline of 1–2 % in the direction of the drain.

Bonded sealing

Requirements:

- The flange is free of heavy soil.
- The complete surface of the flange is lined with material and undamaged.
- Remove the protective cover.

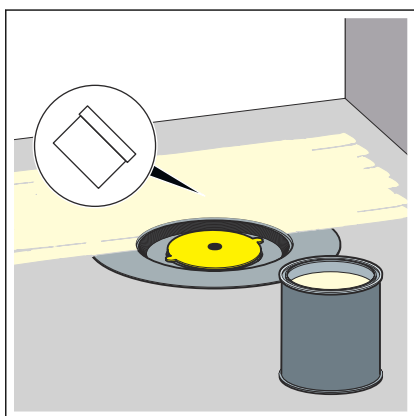
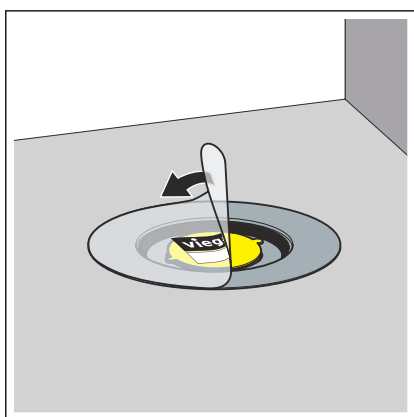

- Apply the bonded sealing on the dry screed and spread to the inner edge of the flange fleece.

NOTICE! Observe the bonded sealing manufacturer's instructions for use.

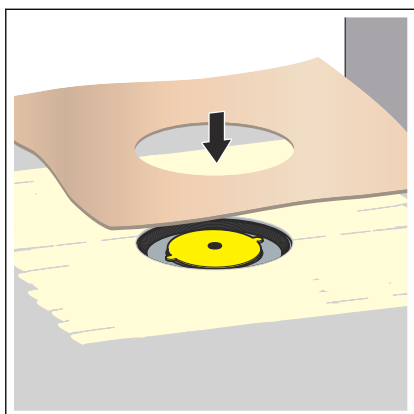

- Lay the sealing collar into the bonded sealing.

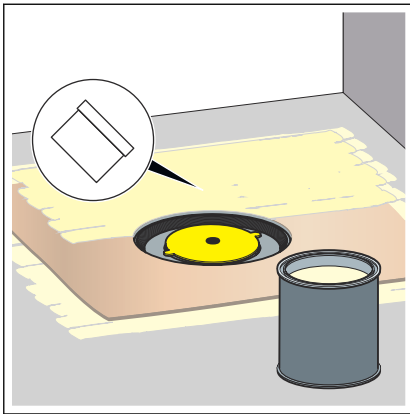

- Apply the second layer of bonded sealing onto the sealing collar and, if necessary, onto the floor.

3.2.4 Mounting the top

The top with the grate must still be mounted to finish off the mounting of the drain. Proceed as follows:

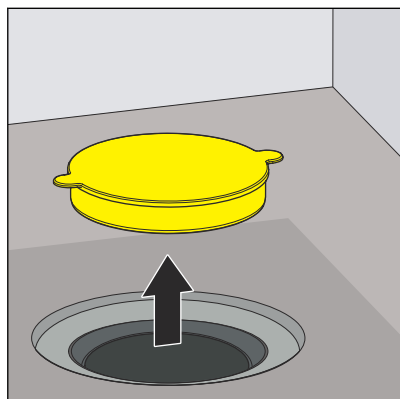

➤ Remove the yellow protective plug.

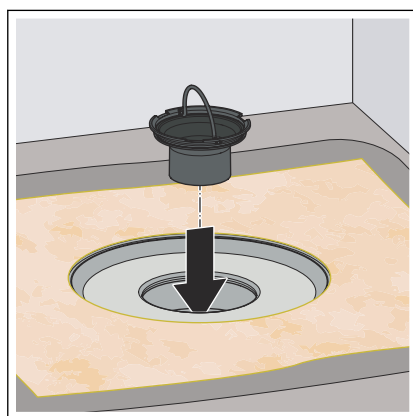

➤ Insert the immersion pipe.

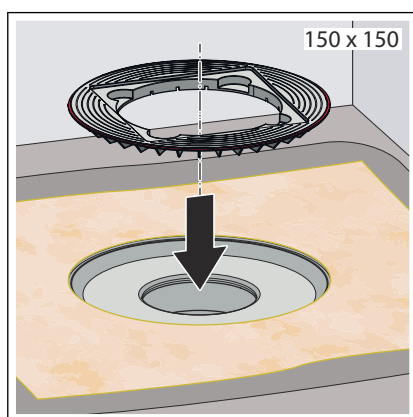

➤ Install the insert ring.

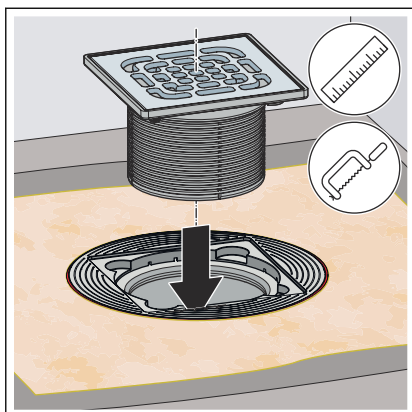

- Cut the top flush to length with the upper edge of the tiles.
- Insert the top without the backflow seal.

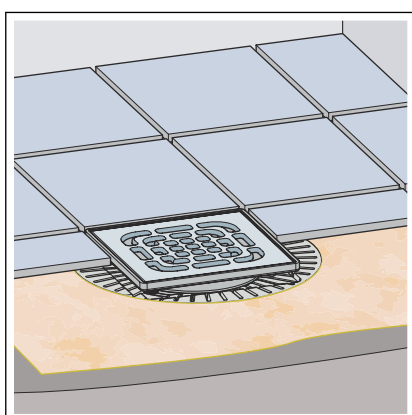

- Clean the insert ring for the top.
 - Lay the tiles (min. tile size 100 x 100 mm).
- Do not allow surface seal and tile adhesive to get in between the top and the flange.
- Viega recommends using epoxy resin adhesive for optimum adhesion.

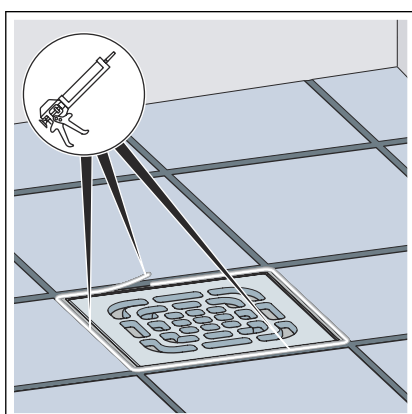

- Close the gap between grate and tiles with silicone.

3.2.5 Consider screed thickness

To ensure that the floor covering is sufficiently stable, an appropriate screed thickness or another suitable alternative solution should be considered.

The following illustrations show three installation options as examples. In all cases, the system must cover the connection pipe by 15 mm.

Normal installation situation, tile size $\geq 100 \times 100$ mm:

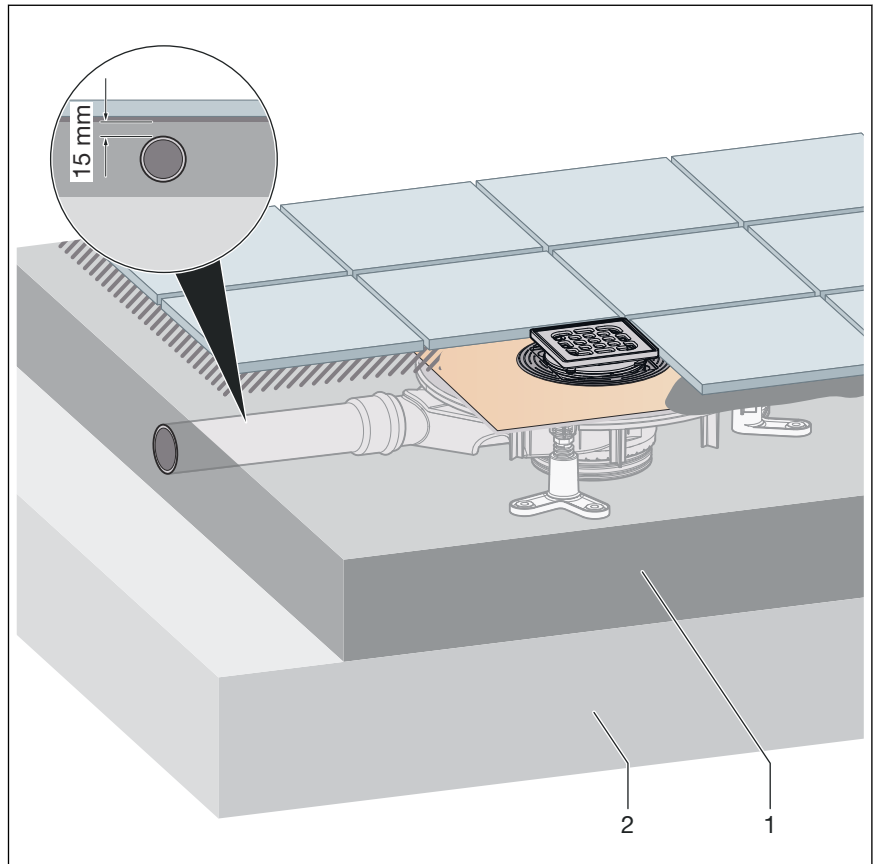

Fig. 8: Screed thickness, normal installation situation

- 1 Screed
- 2 Raw floor

➤ No particular measures are required.

Use of small-format tiles < 100 x 100 mm with offset connection line:

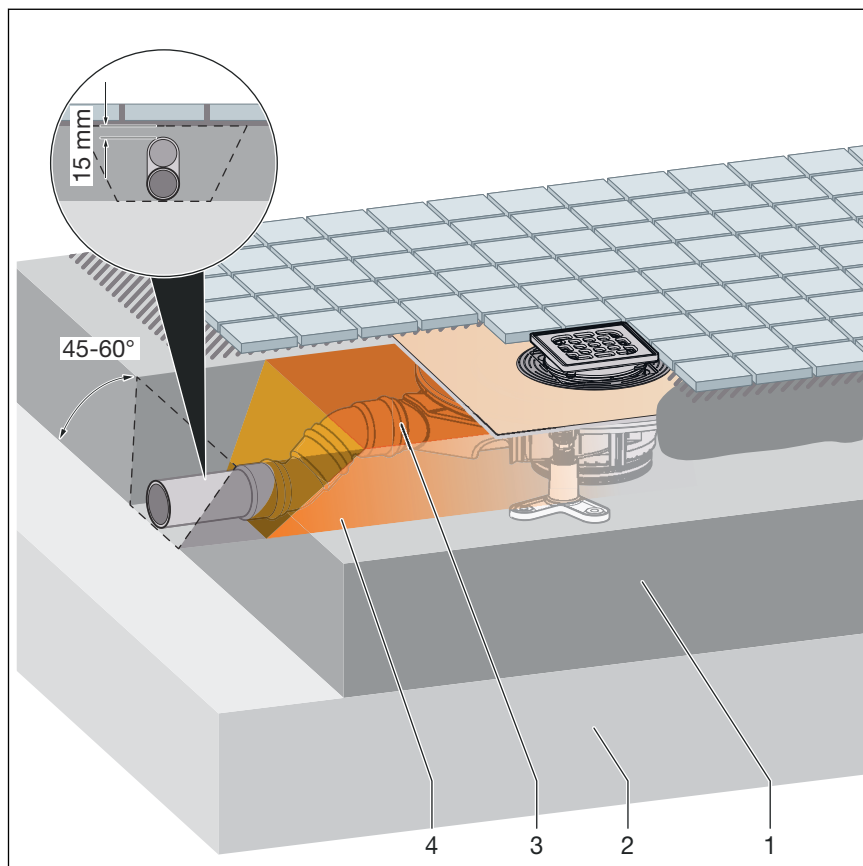

Fig. 9: Screed thickness, with offset connection pipe

- 1 Screed
- 2 Raw floor
- 3 Infill: mortar made of eight parts PCI quartz sand No. II and one part PCI Epoxigrund 390
- 4 Primer: PCI Epoxigrund 390 with quartz sand sprinkling or fresh in fresh

► Carry out filling (3) and priming (4) as mentioned.

Use of small-format tiles < 100 x 100 mm, connection line not offset:

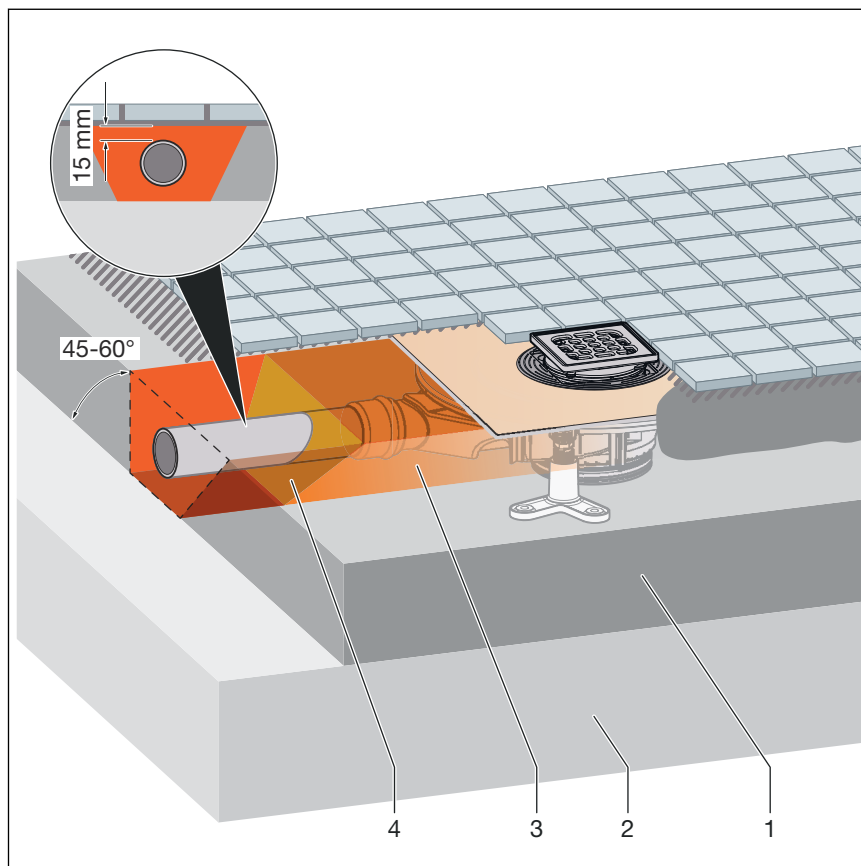

Fig. 10: Screed thickness, connection line not offset

- 1 Screed
 - 2 Raw floor
 - 3 Infill: mortar made of eight parts PCI quartz sand No. II and one part PCI Epoxigrund 390
 - 4 Primer: PCI Epoxigrund 390 with quartz sand sprinkling or fresh in fresh
- Depending on the installation height of the drain and the required pipe slope, make a slope jump directly at the connection pipe using two connection bends.
 - Backfill the area up to a screed cover of 40 mm above the pipe crown.
 - Carry out filling (3) and priming (4) as mentioned.

3.3 Care

3.3.1 Care tips

Normal soap or a mild cleaning agent can be used for regular maintenance and prevention of lime scale on the grate and frame. Use no scouring agent or abrasive objects.

Strong stains, even around the drain unit and the odour trap, can be removed using typical household cleaner. Rinse the detergent very thoroughly with clear water after the prescribed dwell time. There should be no residue on the components.

3.3.2 Cleaning the drain

Use a mild cleaning agent and a washing-up brush for cleaning.

➤ Remove and clean the grate.

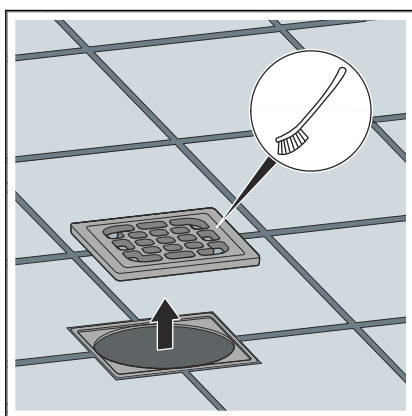

➤ Remove and clean the immersion pipe.

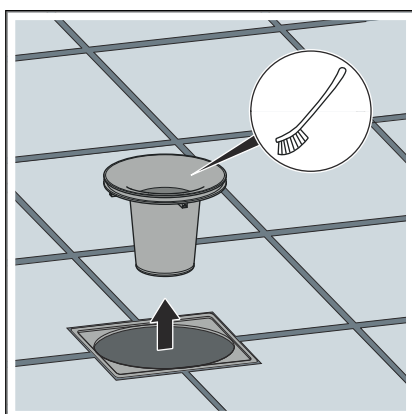

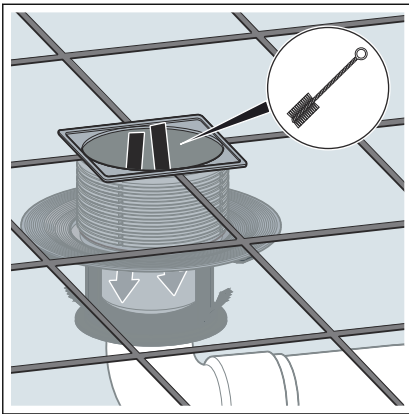

- Clean the drain.
- Replace the immersion pipe.
- Replace the grate.

3.4 Disposal

Separate the product and packaging materials (e. g. paper, metal, plastic or non-ferrous metals) and dispose of in accordance with valid national legal requirements.



Viega GmbH & Co. KG
service-technik@viega.de
viega.com

INT • 2024-06 • VPN240183

