

# Instructions for Use

## Geopress K Gas

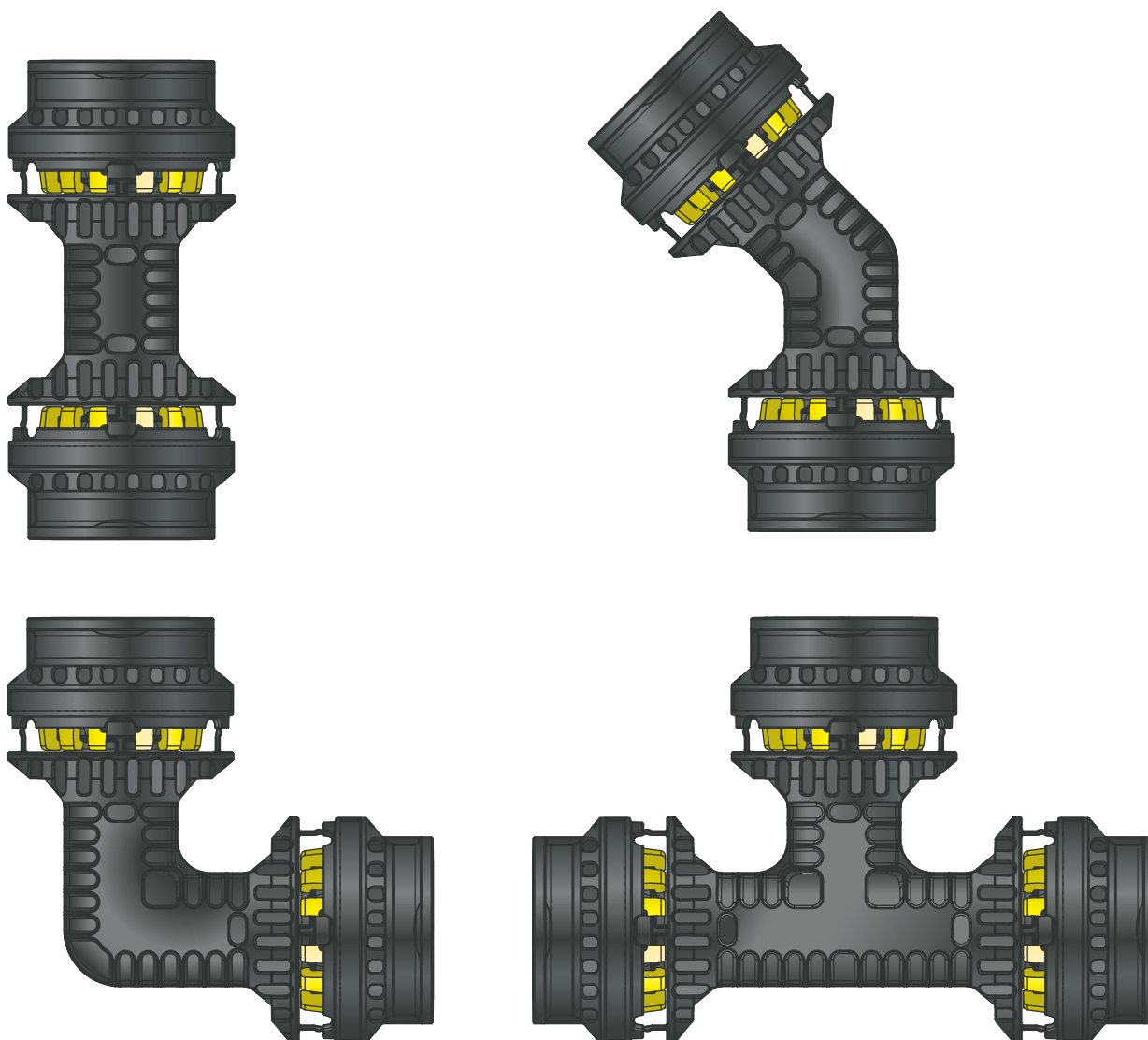

Press connector system made of plastic for underground HDPE pipes

**System**  
Geopress K Gas

**Year built (from)**  
01/2023

**viega**

# Table of contents

<b>1</b>	<b>About these instructions for use</b>	<b>3</b>
	1.1 Target groups	3
	1.2 Labelling of notes	3
	1.3 About this translated version	4
<b>2</b>	<b>Product information</b>	<b>5</b>
	2.1 Standards and regulations	5
	2.2 Intended use	7
	2.2.1 Areas of application	7
	2.2.2 Media	7
	2.3 Product description	8
	2.3.1 Overview	8
	2.3.2 Pipes	8
	2.3.3 Press connectors	9
	2.3.4 Sealing elements	9
	2.3.5 Markings on components	10
	2.4 Information for use	10
	2.4.1 Corrosion	10
<b>3</b>	<b>Handling</b>	<b>11</b>
	3.1 Transport	11
	3.2 Storage	11
	3.3 Assembly information	11
	3.3.1 Mounting instructions	11
	3.3.2 Space requirements and intervals	13
	3.3.3 Required tools	14
	3.4 Assembly	15
	3.4.1 Cutting pipes to length	15
	3.4.2 Deburring the pipes	15
	3.4.3 Pressing the connection	16
	3.4.4 Leakage test	18
	3.5 Disposal	18

# 1 About these instructions for use

Trade mark rights exist for this document; for further information, go to [viega.com/legal](http://viega.com/legal).

## 1.1 Target groups

The information in this manual is directed at utility and pipeline construction companies and their technical professionals.

Only specialist companies which can prove they are qualified in accordance with the applicable directives may be engaged for the construction of gas service connections, see  'Regulations from section: Target group' on page 5.

The installation of Viega products must take place in accordance with the general rules of engineering and the Viega instructions for use.

## 1.2 Labelling of notes

Warning and advisory texts are set aside from the remainder of the text and are labelled with the relevant pictographs.



### **DANGER!**

This symbol warns of possible life-threatening injury.



### **WARNING!**

This symbol warns of possible serious injury.



### **CAUTION!**

This symbol warns of possible injury.



### **NOTICE!**

This symbol warns of possible damage to property.



This symbol gives additional information and hints.

### 1.3 About this translated version

This instruction for use contains important information about the choice of product or system, assembly and commissioning as well as intended use and, if required, maintenance measures. The information about the products, their properties and application technology are based on the current standards in Europe (e.g. EN) and/or in Germany (e.g. DIN/DVGW).

Some passages in the text may refer to technical codes in Europe/Germany. These should serve as recommendations in the absence of corresponding national regulations. The relevant national laws, standards, regulations, directives and other technical provisions take priority over the German/European directives specified in this manual: The information herein is not binding for other countries and regions; as said above, they should be understood as a recommendation.

## 2 Product information

### 2.1 Standards and regulations

The following standards and regulations apply to Germany / Europe. National regulations can be found on the relevant web site of your country at [viega.com.au/standards](http://viega.com.au/standards)

#### Regulations from section: Target group

Scope / Notice	Regulations applicable in Germany
Qualification of specialist companies	DVGW-Arbeitsblatt GW 301

#### Regulations from section: Application areas

Scope / Notice	Regulations applicable in Germany
Planning, execution, modification and operation of gas service connections	DVGW-Arbeitsblatt G 459-1
Planning, execution, modification and operation of liquid gas installations	DVFG-TRF 2021
Planning, execution, modification and operation of gas service connections	DVGW-Arbeitsblatt G 472
Planning, execution, modification and operation of gas service connections	DVGW-Arbeitsblatt G 469

#### Regulations from section: Media

Scope / Notice	Regulations applicable in Germany
Gas, hydrogen and liquid gas in the gaseous state	DVGW-Arbeitsblatt G 260

**Regulations from section: Pipes**

Scope / Notice	Regulations applicable in Germany
Permitted types of pipes (PE) – gas supply	DVGW-Arbeitsblatt GW 335-A2
Types of pipe (PE) – gas supply	DIN EN 1555

**Regulations from section: Press connectors**

Scope / Notice	Regulations applicable in Germany
Thread of Geopress K adapters	DIN EN 10226-1

**Regulations from section: Corrosion**

Scope / Notice	Regulations applicable in Germany
(Subsequent) corrosion protection for underground installation	DIN 30672

**Regulations from section: Transport**

Scope / Notice	Regulations applicable in Germany
Transport	Einbauhinweise KRV A 1465 - Pressure pipelines

**Regulations from section: Storage**

Scope / Notice	Regulations applicable in Germany
Requirements for material storage	Einbauhinweise KRV A 1465 - Pressure pipelines

**Regulations from section: Notes on mounting**

Scope / Notice	Regulations applicable in Germany
Threshold values for ovalities	DIN EN 1555-2, Table 1

## Regulations from section: Leakage test

Scope / Notice	Regulations applicable in Germany
Leakage test before commissioning the connection line	DVGW-Arbeitsblatt G 459-1
Leakage test before commissioning the connection line	DVGW-Arbeitsblatt G 469

## 2.2 Intended use



Agree the use of the system for areas of application and media other than those described with Viega.

The system can be applied at outdoor temperatures from -10 °C to 50 °C. The component temperatures of the press connectors and the press machine must not be less than -5 °C.

### 2.2.1 Areas of application

The model is intended for use in the supply of gas.

For planning, execution, modification and operation of gas service connections, observe the applicable regulations, see ↗ *'Regulations from section: Application areas'* on page 5.

### 2.2.2 Media

The system is suitable for the following media, see ↗ *'Regulations from section: Media'* on page 5:

- Gases including liquid gas in the gaseous phase
- Hydrogen

The max. operating pressure and the max. operating temperature depend on the type of pipe used and the specific application.

- Operating pressure  $p_{\max} = 1000 \text{ kPa}$  (10 bar)

## 2.3 Product description

### 2.3.1 Overview

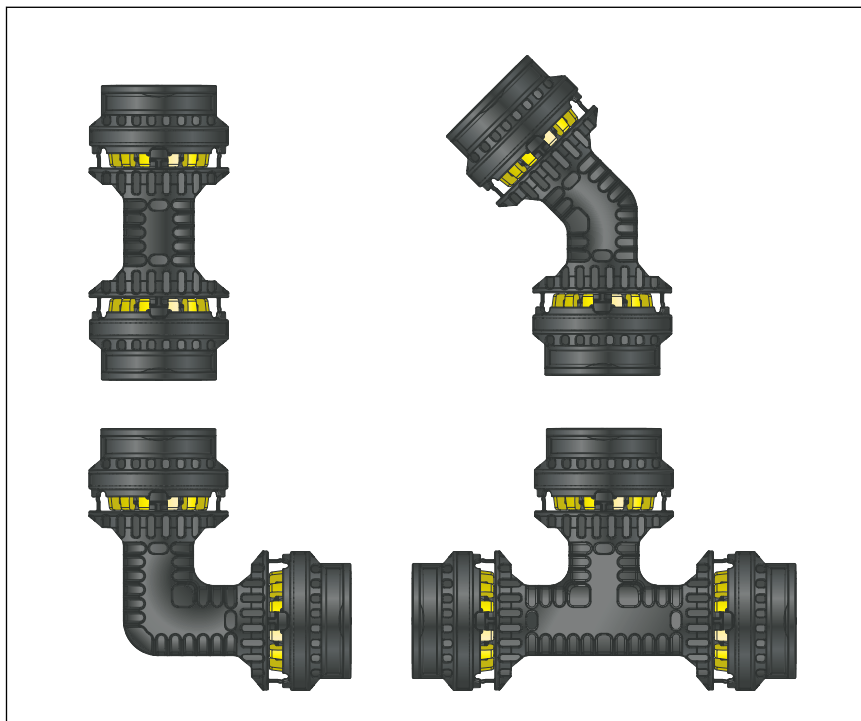

Fig. 1: Overview

The system components are available in the following dimensions:  
d 32 / 40 / 50 / 63.

### 2.3.2 Pipes

Only the following plastic pipes may be used for installations with Geopress K gas components:

#### Permitted types of pipes – gas supply

Type of pipe <sup>1)</sup>	Pipe series SDR	MDP
PE 80	11.0	400 kPa (4 bar)
PE 100	11.0	1000 kPa (10 bar)

<sup>1)</sup> see ↗ 'Regulations from section: Pipes' on page 6



### 2.3.3 Press connectors

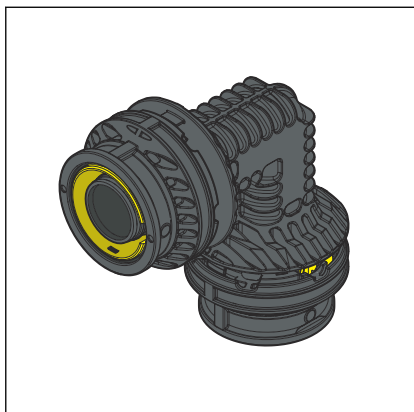

The press connectors have a support sleeve with a 5-tooth sealing contour on it. This sealing contour contains an all-round bead into which an HNBR sealing element is inserted. During the pressing, the pipe is pressed onto the sealing contour of the fitting, creating a seal with the inside of the pipe and a permanent connection. Geopress K Gas press connectors are equipped with a yellow clamping ring made of POM for a longitudinal force resistant connection. The press connectors have a window for checking the insertion depth.

The threads of Geopress K adapters are made of metal and are produced in acc. with the pertinent guidelines, see [Regulations from section: Press connectors](#) on page 6. Plug-in pieces and connecting pieces for the tapping valve also have metal components.

Fig. 2: Press connectors

#### Smart Connect Feature (SC-Contur)

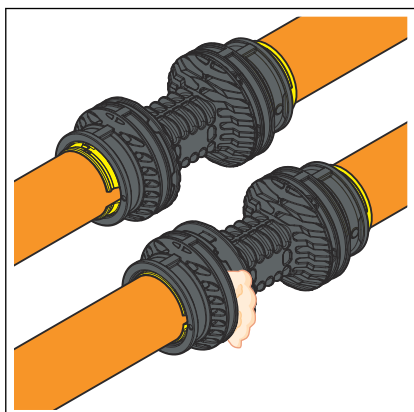

Viega press connectors are equipped with the Smart Connect Feature (SC-Contur). The Smart Connect Feature (SC-Contur) is a safety technology that is certified by the DVGW and ensures that the press connector is guaranteed to be leaky in an unpressed state. In this way, inadvertently unpressed connections are noticed during a leakage test.

Fig. 3: Smart Connect Feature (SC-Contur)

### 2.3.4 Sealing elements

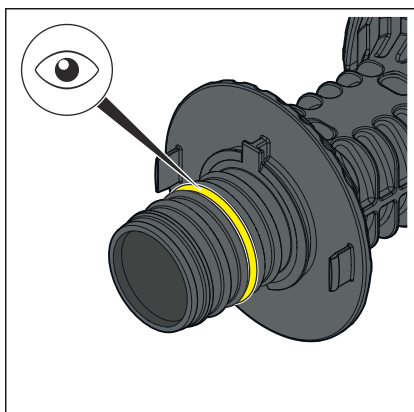
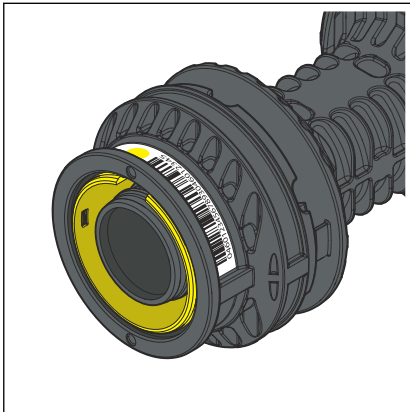

Fig. 4: HNBR sealing element

The press connectors are factory-fitted with HNBR sealing elements.

### 2.3.5 Markings on components



The coloured dot shows that the press connector is equipped with the Smart Connect Feature (SC-Contur)

If there is a yellow dot, the press connector is suitable for gas.

The traceability code on the press connector allows every press connector to be traced back and simplifies the documentation in as-completed drawings.

Fig. 5: Marking

## 2.4 Information for use

### 2.4.1 Corrosion

Where potentially aggressive environments exist, appropriate precautions should be taken to protect the metallic components. Only sealing elements etc. that have appropriate approval or certification should be used.

## 3 Handling

### 3.1 Transport



Do not remove the press connector from the packaging until immediately before use.

Leave the protective caps in the press connector until you are ready to use it.

For transport, comply with the requirements specified in the applicable regulations, see [☞ 'Regulations from section: Transport' on page 6](#)

### 3.2 Storage



Do not remove the press connector from the packaging until immediately before use.

For storage, comply with the requirements specified in the applicable regulations, see [☞ 'Regulations from section: Storage' on page 6:](#)

- Avoid strong sunlight and heating.
- In addition, observe the instructions provided by the pipe manufacturer.

### 3.3 Assembly information

#### 3.3.1 Mounting instructions

##### Checking system components

System components may, in some cases, have become damaged through transportation and storage.

- Check all parts.
- Replace damaged components.
- Do not repair damaged components.

Inspect pipes visually for the following damage before installation:

- Ovalities: threshold values must not be exceeded, see [☞ 'Regulations from section: Notes on mounting' on page 6.](#)
- Dents
- Cracks

- Grooves on the exterior
- Scoring inside the pipe (not permissible)
- damaged pipe ends

Only install the sections of the pipes, which do not exhibit these features.

### Adapter with metal threaded bolt

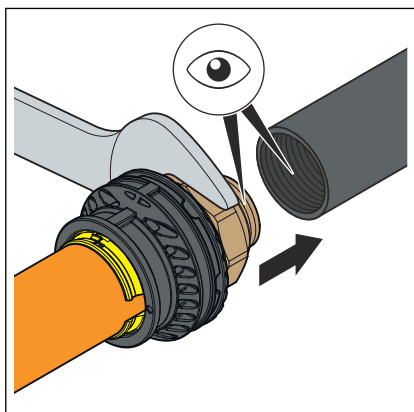

When tightening the threaded connection, only place the spanner on the intended key surfaces.

### Fitting the clamping ring and slip coupling

If the press connector is dirty, the slip coupling and clamping ring can be removed to allow them to be cleaned. The position of the clamping ring and the slip coupling on the connector must be observed when mounting.

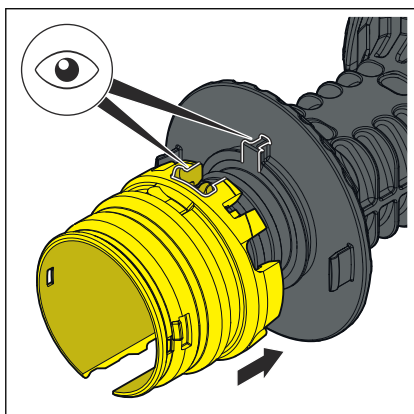

- Engage the clamping ring as shown.

**NOTICE!** Make sure that the sealing element is not damaged when fitting the clamping ring.

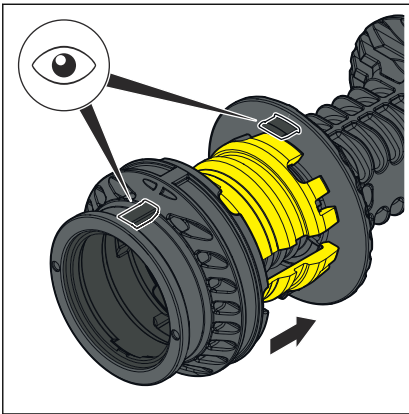

► Fit the slip coupling.

### 3.3.2 Space requirements and intervals

#### Pressing between pipelines

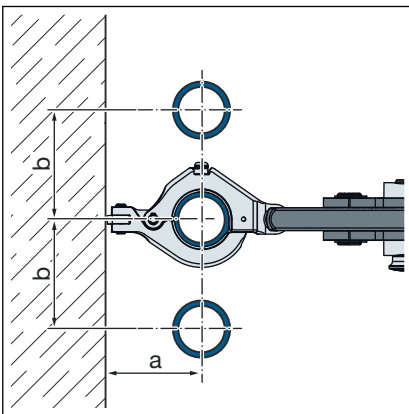

#### Pressing between pipe and wall

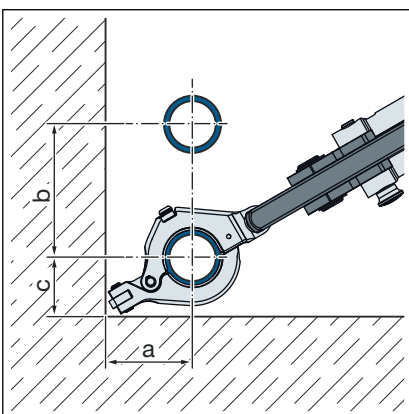

The minimum distance between pipe and wall is 50 mm for all dimensions.

## Interval between the pressings



### NOTICE! Leaking press connections due to pipes being too short!

If two press connectors are to be mounted onto a pipe at a short distance apart, the pipe must not be too short. If the pipe is not inserted up to the prescribed insertion depth in the press connector during pressing, the connection may become leaky.

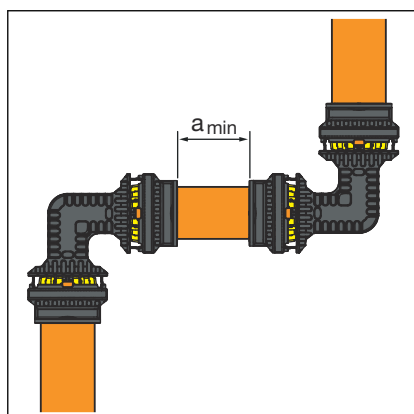

### Minimum distance with press rings d32–63

d	a <sub>min</sub> [mm]
32	20
40	20
50	20
63	20

## Z dimensions

For the Z dimensions, refer to the respective product page in the online catalogue.

### 3.3.3 Required tools

The following tools are required for production of a press connection:

- Pipe cutter, pipe shear or saw
- Deburrer and coloured pen for marking
- Battery-powered press machine
- Hinged adapter jaw model 2296.2
  - Z2 with 32–63 mm diameter



### Viega recommends the use of Viega system tools when installing the press fittings.

The Viega system press tools have been developed and tailored specifically for the installation of Viega press connector systems.

For information on how to combine Viega press machines with systems and accessories, please visit *Viega Tool Assistant*.

### 3.4 Assembly

#### 3.4.1 Cutting pipes to length

For information about tools, also see [Chapter 3.3.3 'Required tools'](#) on page 14.

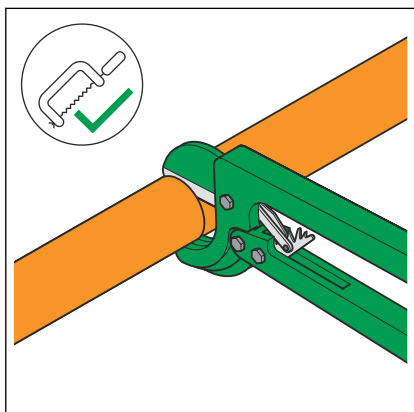
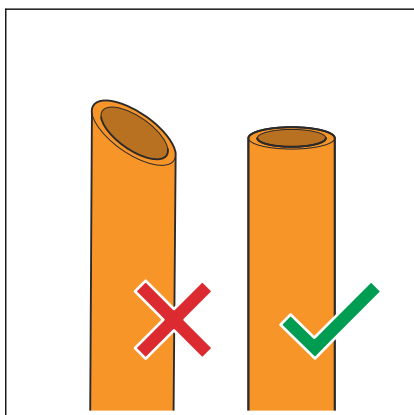

- ▶ Cut the pipe to length at a right angle as accurately as possible using pipe shears, a pipe cutter or a saw to ensure a complete and even pipe insertion depth.

#### 3.4.2 Deburring the pipes

If a burr appears when the pipes are cut, then the pipe ends must be carefully deburred on the inside and outside.

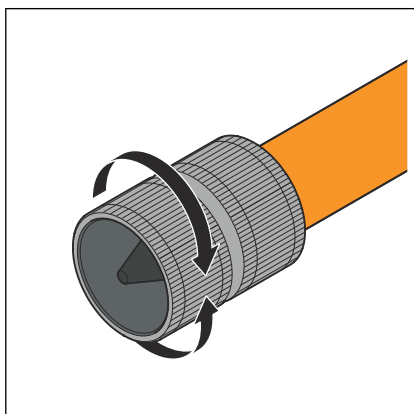

- ▶ Deburr the inside and outside of the pipe.
- ▶ When using protective coated pipe, remove the protective coating according to the manufacturer's instructions.

### 3.4.3 Pressing the connection

Requirements:

- The pipe end is not bent or damaged.
- The protective coating of the protective coated pipe is removed.
- The pipe is deburred.
- Check the pipe surface inside and out for dirt and clean as required. Remove any shavings.

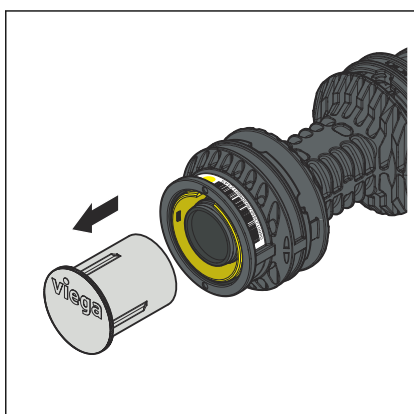
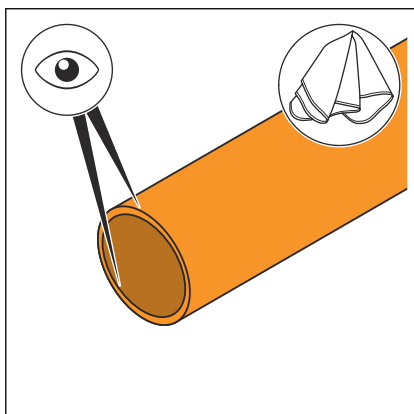

- Remove the protective cap immediately before fitting the pipe and protect the connection against dirt ingress.

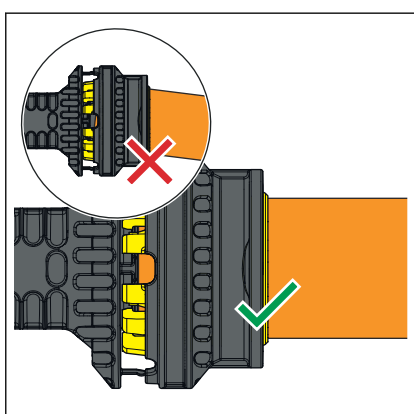

- To avoid damaging the sealing element, push the press connector straight onto the pipe without twisting.



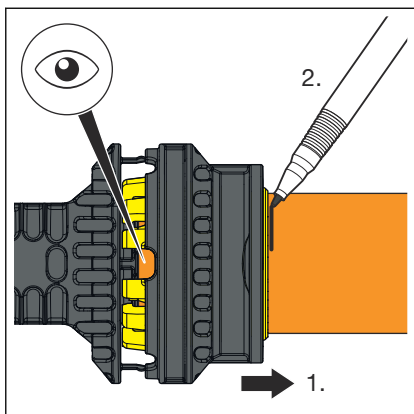

- Check the insertion depth in the inspection window and mark it.

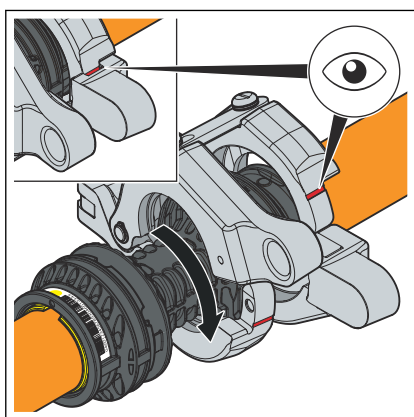

- Open the press ring and check for dirt and function.
  - Position the press ring around the connector.
- Observe the press connector side and pipe side of the press ring.  
The press ring is properly closed when the red marking can no longer be seen.

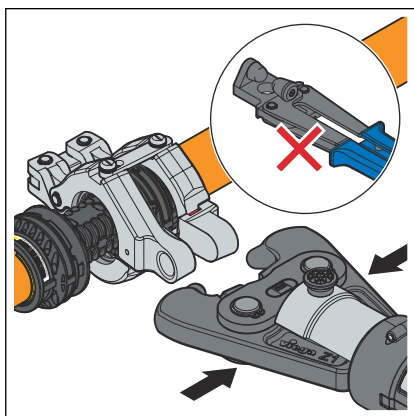

- Open the hinged adapter jaw and latch it into the concave lugs of the press ring.

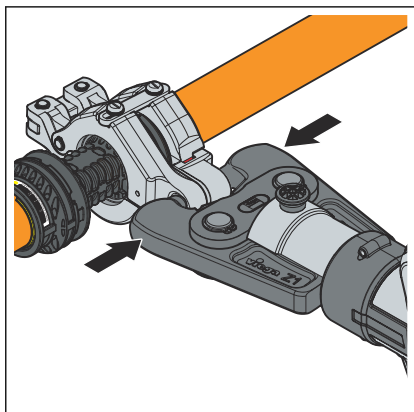

- Carry out the pressing.

### NOTICE!

The press ring must close completely during pressing.

- Make sure there is adequate space at the pressing point.
- Keep the press jaw contour and the area around the pressing point clean.

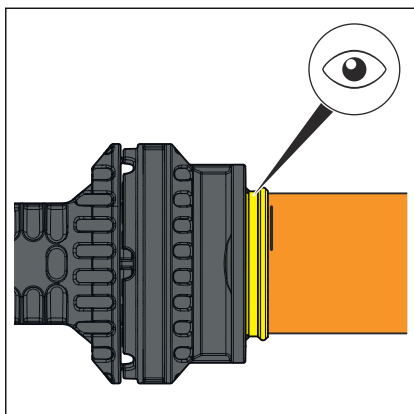

- The clamping ring is easily recognised after successful pressing.
- ◻ The connection is marked as having been pressed.
- Check the insertion depth.

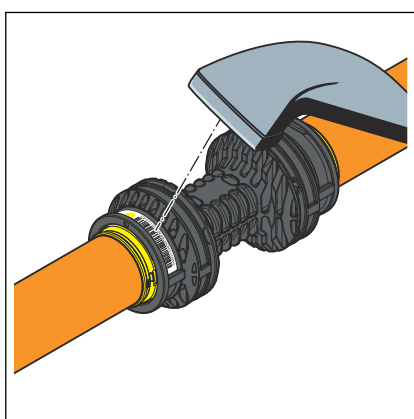

- Scan in the traceability code.

### 3.4.4 Leakage test



The leakage test can be carried out directly after the last pressing.

## 3.5 Disposal

Separate the product and packaging materials (e. g. paper, metal, plastic or non-ferrous metals) and dispose of in accordance with valid national legal requirements.



**Viega Pty Limited**  
support@viega.com.au  
viega.com.au

AU • 2023-08 • VPN220003

